

<b>Chapter 1 Safety Requirement and Cautions</b> -----	3
1.1 Safety Definition-----	3
1.2 Safety Requirements and Cautions -----	3
1.3 Cautions in Using -----	6
1.4 Technical Specification-----	6
1.5 Cautions in Disposal-----	7
<b>Chapter 2 Installation and Wiring</b> -----	8
2.1 Products Appearance-----	8
2.2 Open Cover -----	8
2.3 Wiring and grounded (The ground wire must be firmly connected) -----	9
2.4 Inverter Dimension-----	9
2.5 Terminal diagram-----	10
2.6 Terminal diagram-----	10
<b>Chapter 3 Basic Operation and Trial Run</b> -----	11
3.1 Keyboard Layout and Function Specification (optional)-----	11
3.2 GPRS: IOT-GWS module and APP application (optional)-----	12
3.3 Panel button (standard configuration)-----	13
<b>Chapter 4 Fault Diagnosis and Solution</b> -----	14
<b>Chapter 5 Parameters List</b> -----	21
<b>Chapter 6 Function Parameter Specifications</b> -----	61
6.1 F0: Basic Parameters -----	61
6.2 F1: Operation Control Parameters Group-----	71
6.3 F2: Switching Value Terminal Parameters -----	81
6.4 F3: Analog Terminal Parameters -----	103
6.5 F4: Keyboard and Display Parameters -----	111
6.6 F5: Motor Parameters-----	122
6.7 F6: VC Control Parameter -----	127
6.8 F7: Torque Control Parameters -----	131
6.9 F8: V/F Control Parameters-----	134
6.10 F10: Malfunction and Protection Parameters-----	139
6.11 F11: PID Parameters -----	148
6.12 F12: Multi-step, PLC Function and Swing Frequency Parameters	156

6.13 F13: Communication Control Function Parameters ----- 163

6.14 F14: Photovoltaic Pump Special Parameters ----- 169

**Chapter 6 Operation Guidance ----- 183**

6.1 AM Motor Pump Drive Operation Guidance (Keyboard as an example)  
----- 183

6.2 Synchronous Motor Pump Drive Operation Guidance ----- 184

6.3 PV Water Pump Features ----- 184

Version number	Software Version	Modified content	Director
V1.0	6910	Initial version, detailing the parameters	Chris

## Chapter 1 Safety Requirement and Cautions

To ensure safety of your health, equipment and property, please read this chapter carefully before using the solar pump inverter and act in compliance with the instructions when installing, debugging, running and overhauling the inverter.

### 1.1 Safety Definition

**Danger:** it will cause danger of serious injuries and even death while operating against the rules.

**Caution:** it will cause danger of light injuries or equipment destruction while operating against the rules.

Note: some information is useful while operating and using solar pump inverter.

### 1.2 Safety Requirements and Cautions

#### • Before Installation

<b>Danger</b>
<ol style="list-style-type: none"> <li>1. Only qualified personnel can operate the equipment. Before operating, be sure to carefully read the manual. The safe operation depends on the proper processes of choosing models, carrying, installation, operation and maintenance.</li> <li>2. Don't use the damaged or incomplete solar pump inverters; Otherwise, there is risk of injury.</li> </ol>

#### • Installation

<b>Danger</b>
<ol style="list-style-type: none"> <li>1. Please install the solar pump inverter on metal or other nonflammable material, and keep it away from the combustible material. Otherwise there is danger of fire.</li> <li>2. No unauthorized modification to the solar pump inverter; Otherwise there is danger of damage.</li> <li>3. Normal solar pump inverter without explosion-proof cannot be installed where with explosive gas or dust; Otherwise there is danger of explosion.</li> </ol>

#### • Wiring

<b>Danger</b>
<ol style="list-style-type: none"> <li>1. Wire is connected only when the main circuit is cut off, otherwise there is a danger of shock.</li> <li>2. Wire is connected by professional person only. Otherwise there is a danger of shock.</li> <li>3. Earth must be reliable. Otherwise there is a danger of shock.</li> <li>4. DC power supply should not be connected to output terminals U, V, W, otherwise there is a danger of damage to solar pump inverter.</li> <li>5. No drop of bolt, spacer, metal stick, conducting wire or other things into the inner of solar pump inverter; Otherwise there is a danger of fire or damage to solar pump inverter.</li> </ol>

**Attention**

1. If the damage to solar pump inverter or other equipment is caused by improper wiring and utilization or unauthorized alteration, the user should shoulder all responsibilities.
2. Please make sure all wirings meet EMC requirements and satisfy safety standards in the local area; Please refer to recommendations in this manual or national standards of wire diameter to avoid accidents.
3. Static electricity on human body would seriously damage internal MOS transistor, etc. Don't touch the printed circuit boards, IGBT or other internal devices without anti-static measurements; otherwise it will cause the malfunction to solar pump inverter.
4. Please don't connect phase shift capacitance or LC/RC noise filter to the output circuit of solar pump inverter; Otherwise it will damage the inverter.
5. Please don't connect the magnetic switch or magnetic contactor to the output circuit of solar pump inverter; When solar pump inverter is in the operation with load, magnetic switch or magnetic contactor can make inverter over-current protection act. It will damage solar pump inverter seriously.
6. Please don't dismantle the panel cover, and it only needs to dismantle the terminal cover when wiring.
7. It is forbidden to do any pressure test on solar pump inverter, otherwise it will damage the solar pump inverter.

**• Before Electrification****Danger**

1. Please make sure that voltage grade of power supply is consistent with solar pump inverter's rated voltage and then check whether the wiring is correct, and whether there is short circuit in peripheral equipment's circuit. Otherwise it will damage solar pump inverter and other equipment.
2. Before the solar pump inverter is connected to the input power supply, make sure that the cover has been well fixed. Otherwise it will cause electric shock.
3. For the solar pump inverters whose storage time is over 1 year, when electrification, the voltage should be raised by booster from low to high. Otherwise it will damage the solar pump inverter.

**Attention**

1. Check if all periphery fittings are wired properly according to the handbook; Otherwise it will cause accidents.

### ● After Electrification

<b>Danger</b>
<ol style="list-style-type: none"> <li>1. After electrified, it is forbidden to open the cover, make wiring, and check up; Otherwise, it will cause the danger of electric shock.</li> <li>2. After electrified, it is forbidden to contact internal wiring board and its parts. Otherwise it will cause the danger of electric shock.</li> <li>3. Do not operate or touch solar pump inverter with wet hand. Otherwise there is danger of damage to solar pump inverter and electric shock.</li> </ol>
<b>Attention</b>
<ol style="list-style-type: none"> <li>1. Please set the parameter of solar pump inverter cautiously; Otherwise it will damage equipment.</li> </ol>

### ● Operation

<b>Danger</b>
<ol style="list-style-type: none"> <li>1. Before running, please check and confirm the application range of the machine and equipment once more; Otherwise it will cause accidents.</li> <li>2. Please don't touch the cooling fan and braking resistance to check the temperature; Otherwise there is a danger of getting burn.</li> <li>3. Unprofessional workers are banned to check the signals in the running stage; Otherwise it will cause injuries and damage the equipment.</li> </ol>

<b>Attention</b>
<ol style="list-style-type: none"> <li>1. Please don't turn off the equipment by switching off power; Please cut off the power supply after the electric machine stops running; Otherwise it will damage the solar pump inverter.</li> <li>2. Please avoid anything dropping into the equipment when the solar pump inverter is running; Otherwise it will cause electric shock.</li> </ol>

### ● Maintenance

<b>Danger</b>
<ol style="list-style-type: none"> <li>1. Please don't maintain and repair the equipment with electric; Otherwise it will cause electric shock.</li> <li>2. Before maintaining and repairing the solar pump inverter, please make sure the indicator lights of power supply have completely turned off; Otherwise it may cause electric shock and damage the solar pump inverter.</li> <li>3. Persons who have not passed specialized train are not allowed to conduct the solar pump inverter maintenance; Otherwise it may cause electric shock and damage the solar pump inverter.</li> </ol>

### 1.3 Cautions in Using

1. In application of this series solar pump inverter, you have to confirm all machine insulation to prevent damage to the equipment. Moreover, when the motor working in tough environment, please periodic inspect the electrical insulation to ensure the safety of the system work.
2. If the motor adapter is not consistent with solar pump inverter's rating current (The rating current of the motor is far smaller than that of solar pump inverter), please adjust the protective value to ensure safe running.
3. In occasions such as load raises, usually there is negative torque and solar pump inverter breaks off for over-current or over-voltage. In this case, you should consider choosing the matching brake unit.
4. Solar pump inverter, in a certain output frequency range, can meet the mechanical resonance of the load equipment. To avoid it, you can set up jumping frequency.
5. As output voltage of the inverter is pulse-wave type, if there is capacity which can improve power factor or pressure-sensitive resistance which used for thunder-proof in the voltage output side, the solar pump inverter will break off or its parts will be damaged, so it is necessary to dismantle them. Moreover, it is proposed not install switch parts like air switch and contactor (if it is necessary to install switch on output side, please make sure the output electricity of solar pump inverter is zero when the switch is working).
6. At over 1,000 meters altitude, the inverter's heat dissipation function worsened due to the thin air, it is necessary to use less.
7. The inverter output voltage is pulse wave type. If using digital multi-meter measurement, deviation of the reading will be great. And the deviation is different by using different type of digital multi-meter. Under normal circumstances, while RMS 380V, digital multi-meter reading is around 450V.
8. Solar panel can be connected in series or parallel. For rated voltage 380V controller, we suggest solar panel open circuit voltage should be between 620V~750V.

### 1.4 Technical Specification

Solar pump inverter power(kW)	Pump		Max solar power input (kW)	Max DC input voltage (V)	Recommend Voc voltage (V)	Rated output current (A)	Output frequency (Hz)
	Rated power (kW)	Rated voltage (V)					
<b>SI30-D1 series, DC90V-400V input, 3 phase AC110V-230V output, MPPT voltage range DC90V-400V, for AC110V pumps</b>							
0.75	0.75	110	1.0	400	175~380	7A	0-320
1.5	1.5	110	1.95	400	175~380	10A	0-320
<b>SI30-D3 series, DC150V-450V input, 3 phase AC220V-240V output, MPPT voltage range DC150V-450V, for AC220V pumps</b>							
0.75	0.75	220	1.0	450	360~430	4A	0-320
1.5	1.5	220	1.95	450	360~430	7A	0-320
2.2	2.2	220	2.86	450	360~430	10A	0-320
<b>SI30-D5 series, DC300V-850V input, 3 phase AC230V-460V output, MPPT voltage range DC300V-800V, for AC380V pumps</b>							
0.75	0.75	380	1.0	850	620~750	2.5	0-320
1.5	1.5	380	2.2	850	620~750	3.7	0-320
2.2	2.2	380	3.3	850	620~750	5.0	0-320
4	3.7	380	5	850	620~750	10	0-320
5.5	5.5	380	8	850	620~750	13	0-320

7.5	7.5	380	10	850	620~750	17	0-320
11	11	380	14.3	850	620~750	25	0-320

### 1.5 Cautions in Disposal

When you dispose solar pump inverter, please pay attention to:

1. Electrolytic capacitor: the electrolytic capacitor of main circuit or the printing plate may explode when they are burned.
2. Plastic: plastic incineration may generate toxic gases.
3. Dispose method: please dispose as industrial waste.

## Chapter 2 Installation and Wiring

### 2.1 Products Appearance

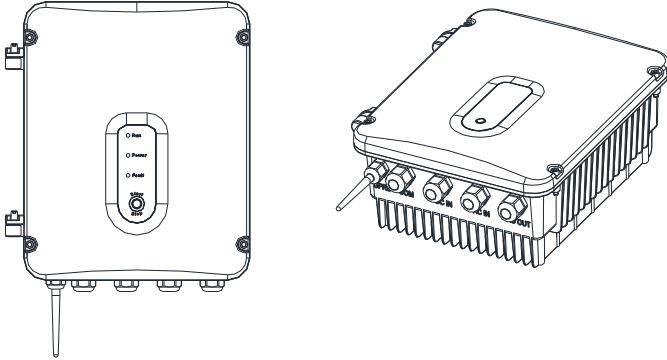

### 2.2 Open Cover

Remove 4 fixed screws in the cover and turn from right to left to open the top cover, as shown below:





### 2.3 Wiring and grounded (The ground wire must be firmly connected)

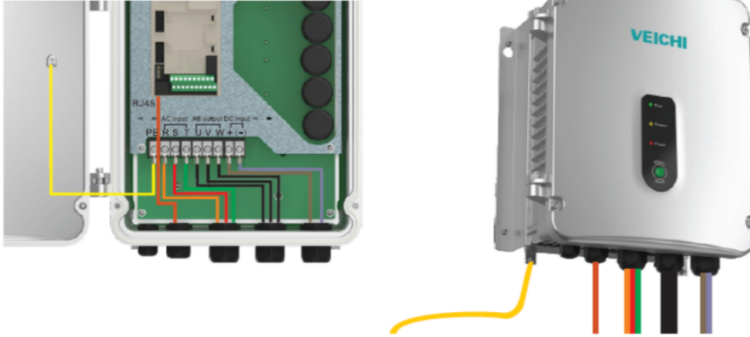

### 2.4 Inverter Dimension

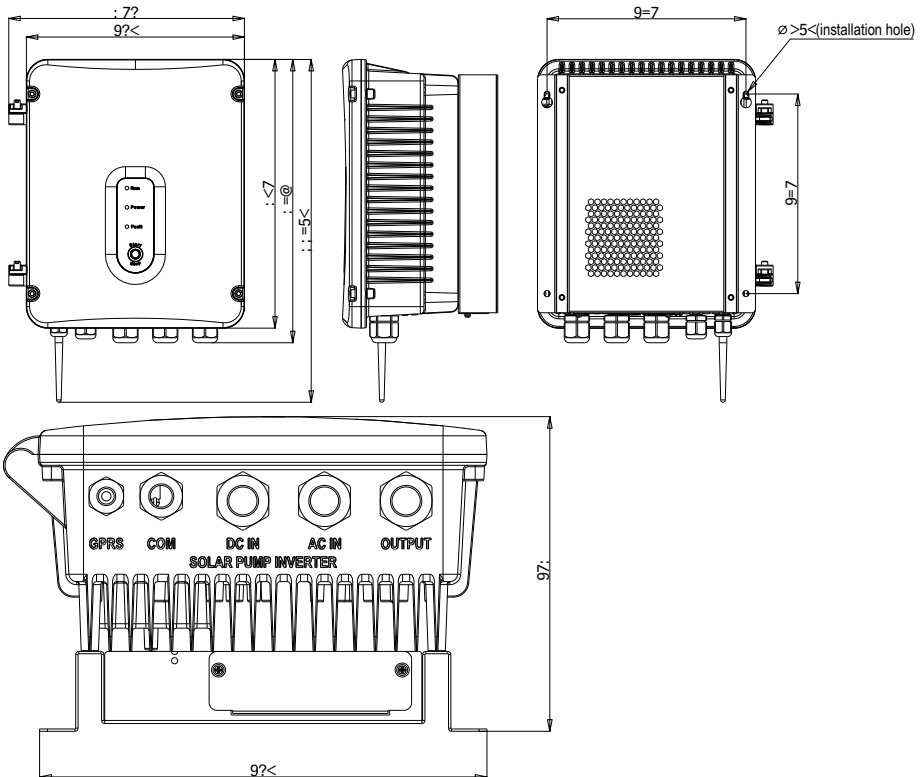

## 2.5 Terminal diagram

- Control loop terminal instructions

Terminal	Function definition	Description
+10V	10V auxiliary power supply output, constitutes loop with	MAX output 50mA
+24V	24V auxiliary power supply output, constitutes loop with	MAX output 100mA
COM	24V power reference ground	MAX output 24VDC/100mA
A+	RS485 communications +	
B-	RS485 communications -	
AI1	analog input 1	Voltage, current type optional
AI2	analog input 2	Voltage, current type optional
GND	analog signal ground	
X1	Forward running input, and constitutes loop with COM	
X2	Reverse running input, and constitutes loop with COM	
X3	Full water detection alarm, and constitutes loop with COM	
X4	Full water detection reset, and constitutes loop with COM	
RJ45	External keyboard connection terminal	

## 2.6 Terminal diagram

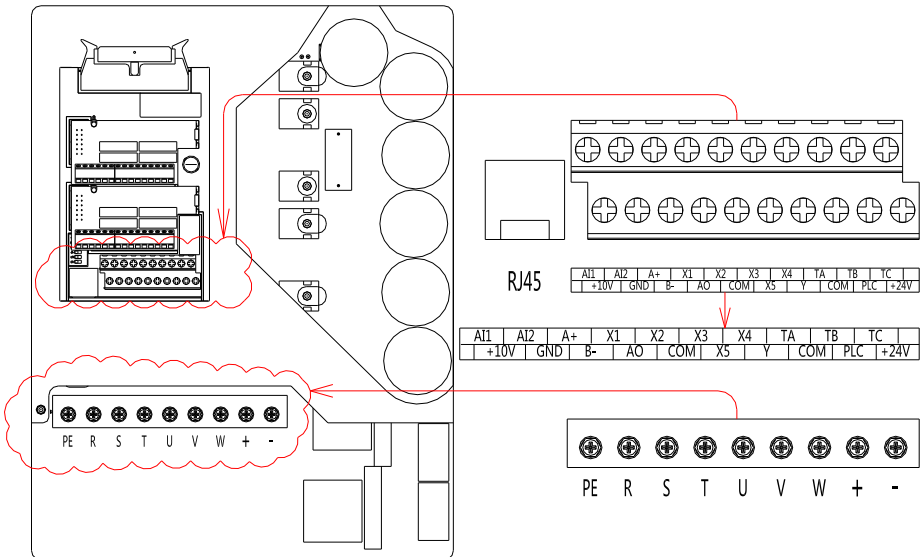



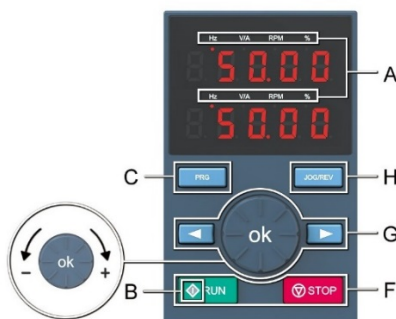

## Chapter 3 Basic Operation and Trial Run

### 3.1 Keyboard Layout and Function Specification (optional)

#### ● Keyboard Appearance



#### ● Key Function

Symbol	Double-line keyboard	Function
A	Unit indicator	Hz: Frequency A: Current V: Voltage V/A: Voltage or current RPM: Speed %: Percentage
B	Status Indicator	On: Forward running status Blinking: Reverse running status Off: Stop status
C	Menu 	Enter the function menu interface during standby or running; press this button to exit the modification when the parameter is modified; press the button (1 second) during standby or running to enter the status interface directly.
F	Stop/Reset 	When the command given channel is keyboard control, press this key to stop the inverter; the parameter [F04.08] can be used to define whether other command channels are valid; the inverter resets when pressing the key in fault status.
G		Digital potentiometer: clockwise to increase the operating value, counterclockwise to decrease the operating value
	Left/Right Shift 	Move left and right operation bits
H	Jog/Reverse 	Select the function of the key by parameter [F04.07], 0: reverse 1: jog

## 3.2 GPRS: IOT-GWS module and APP application (optional)

- IOT-GWS module appearance and wiring diagram

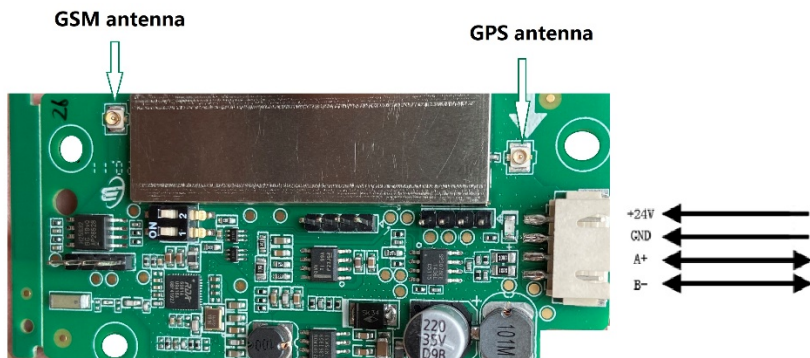

- APP main interface and function introduction

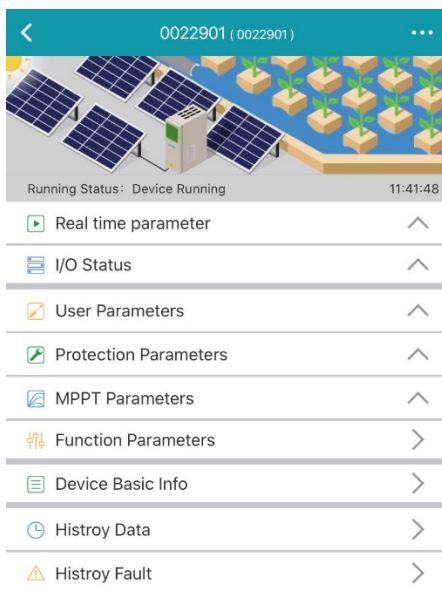

### 3.3 Panel button (standard configuration)

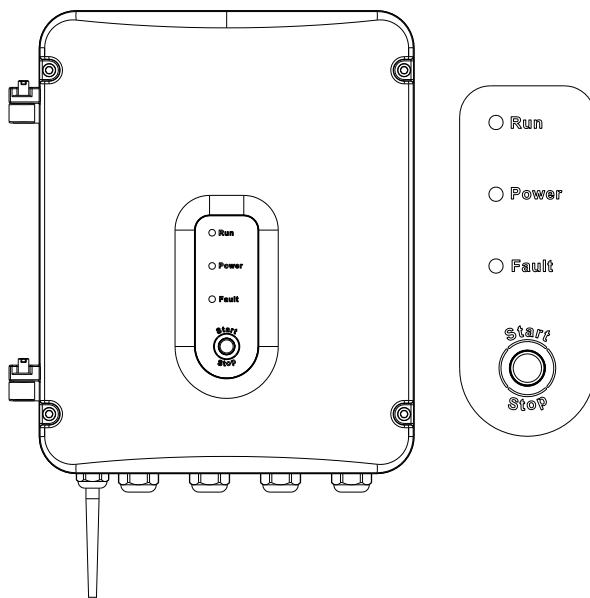





It is able to complete start /stop operation on inverter by pressing [Start/Stop] key in the cover panel only when F0.02=0. Pressing the key to start it when it is in stop status. While it is in running status, press the key to stop it. And user can also press the key to reset it when it is in fault status. The "Power" indicator will be on once power on and "Run" indicator will be on when inverter is running. As fault comes, "Fault" indicator will be always on. While "Fault" indicator is blinking, alarm comes.

## Chapter 4 Fault Diagnosis and Solution

This chapter describes the inverter fault, alerts, and operation of the failure on the inverter, the display information on inverter and countermeasures. In addition, the poor condition of the drive and motor failures will be briefly described in this chapter. Tuning guide on commissioning of the drive please refer this chapter.

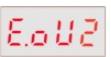
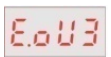
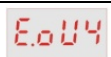
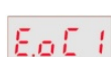
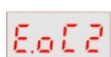

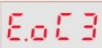
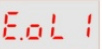





### Fault Information and Description in Detail

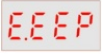

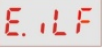







Keypad display	Fault code	Fault type	Possibility reason	Troubleshooting
	E.LU2	Under voltage at runs	<ul style="list-style-type: none"> <li>●Power voltage too low</li> <li>●DC main contactor don't close</li> </ul>	<ul style="list-style-type: none"> <li>●Check input power to solve</li> <li>●Ask support</li> </ul>
	E.oU1	Over voltage at acceleration	<ul style="list-style-type: none"> <li>●Power voltage fluctuation over limit</li> <li>●Too start rotating motor</li> </ul>	<ul style="list-style-type: none"> <li>●Check power grid</li> <li>●Restart until motor is stop completely, or set[F1.00] set for 1 or 2</li> </ul>
	E.oU2	Over voltage during deceleration	<ul style="list-style-type: none"> <li>●Deceleration time too small</li> <li>●The driving load too heavy</li> <li>●Power voltage fluctuation over limit</li> </ul>	<ul style="list-style-type: none"> <li>●Prolong deceleration time</li> <li>●Reduce the load, or select bigger capacitor drive, or connect braking unit</li> <li>●Check input power</li> </ul>
	E.oU3	Overvoltage at constant speed	<ul style="list-style-type: none"> <li>●The input voltage is too high</li> <li>●An external force drives the motor during deceleration</li> </ul>	<ul style="list-style-type: none"> <li>●Adjust the voltage to normal range</li> <li>●Cancel the external force or install the braking resistor</li> </ul>
	E.oU4	Over voltage at stop	<ul style="list-style-type: none"> <li>●Voltage fluctuate above limit</li> </ul>	<ul style="list-style-type: none"> <li>●Check the input voltage</li> </ul>
	E.oC1	Over current during acceleration	<ul style="list-style-type: none"> <li>●Acceleration time is too short</li> <li>●To start rotating motor</li> <li>●V/F setting not correct or torque boost setting too big</li> <li>●Solar drive capacitor is too small</li> </ul>	<ul style="list-style-type: none"> <li>●Prolong acceleration time</li> <li>●Restart motor when it on still, or set F1.00 for 1 or 2</li> <li>●Reset V/F curve or torque boost setting</li> </ul>
	E.oC2	Over current during deceleration	<ul style="list-style-type: none"> <li>●The output circuit is grounded or short circuited</li> <li>●Motor auto-tuning is not performed</li> </ul>	<ul style="list-style-type: none"> <li>●Eliminate external faults</li> <li>●Perform the motor auto tuning</li> </ul>







			<ul style="list-style-type: none"> <li>●The acceleration time is too short</li> <li>●Manual torque boost or V/F curve is not appropriate</li> <li>●The voltage is too low</li> <li>●The startup operation is performed on the rotating motor</li> <li>●A sudden load is added during acceleration</li> <li>●The AC drive model is of too small power class</li> </ul>	<ul style="list-style-type: none"> <li>●Increase the acceleration time</li> <li>●Adjust the manual torque boost or V/F curve</li> <li>●Adjust the voltage to normal range</li> <li>●Select rotational speed tracking restart or start the motor after it stops</li> <li>●Remove the added load</li> <li>●Select an AC drive of higher power class</li> </ul>
	E.oC3	Over current at constant speed	<ul style="list-style-type: none"> <li>●The output circuit is grounded or short circuited</li> <li>●Motor auto-tuning is not performed</li> <li>●The voltage is too low</li> <li>●A sudden load is added during operation</li> <li>●The AC drive model is of too small power class</li> </ul>	<ul style="list-style-type: none"> <li>●Eliminate external faults</li> <li>●Perform the motor auto tuning</li> <li>●Adjust the voltage to normal range</li> <li>●Remove the added load</li> <li>●Select an AC drive of higher power class</li> </ul>
	E.oL1	Motor overload	<ul style="list-style-type: none"> <li>●Boost torque is too big under VF control</li> <li>●ACC. and DEC. time is too short</li> <li>●Motor parameters setting is improperly</li> <li>●Restart motor which in counter rotate</li> <li>●The grid voltage is too lower</li> <li>●Load is too big or motor block load</li> <li>●AC drive selected is too load</li> </ul>	<ul style="list-style-type: none"> <li>●Reduce boost torque</li> <li>●Increase the ACC./DEC. time</li> <li>●Reset motor parameters</li> <li>●Reduce current limit and adopt speed tracking</li> <li>●Check grid voltage</li> <li>●Check load condition</li> <li>●Change bigger power AC drive</li> </ul>
	E.oL2	AC drive overload	<ul style="list-style-type: none"> <li>●Boost torque is too big under VF control</li> <li>●ACC. and DEC. time is too short</li> </ul>	<ul style="list-style-type: none"> <li>●Reduce boost torque</li> <li>●increase the ACC./DEC. time</li> <li>●reset motor parameters</li> </ul>

			<ul style="list-style-type: none"> <li>●Motor parameters setting is improperly</li> <li>●Restart motor which in counter rotate</li> <li>●The grid voltage is too lower</li> <li>●Load is too big or motor block load</li> <li>●AC drive selected is too load</li> </ul>	<ul style="list-style-type: none"> <li>●Reduce current limit and adopt speed tracking</li> <li>●Too check grid voltage</li> <li>●Too check load</li> <li>●change bigger power AC drive</li> </ul>
E.oL2	E.SC	System abnormal	<ul style="list-style-type: none"> <li>●Deceleration is too short</li> <li>●Short circuit of solar drive output or phase output short circuit to ground</li> <li>●Module damage</li> <li>●EMC interface</li> </ul>	<ul style="list-style-type: none"> <li>●Prolong acceleration time</li> <li>●To check peripheral equipment</li> <li>●Ask to support</li> <li>●Check the wiring layout,cable ground</li> </ul>
E.oH1	E.oH1	Inverter over-heat	<ul style="list-style-type: none"> <li>●Temperature is too high</li> <li>●Air channel is blocked</li> <li>●Fan connection parts is loose</li> <li>●Fan is damaged</li> <li>●Temperature detection circuit fault</li> </ul>	<ul style="list-style-type: none"> <li>●Make the environment meet the requirement</li> <li>●Clear the air channel</li> <li>●Check and reconnect the wire</li> <li>●Change the same new fan</li> <li>●Seek support from factory</li> </ul>
E.oH2	E.oH2	Rectifier over-heat	<ul style="list-style-type: none"> <li>●Temperature is too high</li> <li>●Air channel is blocked</li> <li>●Fan connection parts is loose</li> <li>●Fan is damaged</li> <li>●Temperature detection circuit fault</li> </ul>	<ul style="list-style-type: none"> <li>●Make the environment meeting the requirement</li> <li>●Clear the air channel</li> <li>●Check and reconnect the wire</li> <li>●Change the same new fan</li> <li>●Seek support from factory</li> </ul>
E.TE1	E.TE1	Motor static detection fault	<ul style="list-style-type: none"> <li>●Detection overtime</li> <li>●Start static detection while motor is running</li> <li>●Capacitance difference is too big between motor and inverter</li> <li>●Motor parameter setting</li> </ul>	<ul style="list-style-type: none"> <li>●Check motor connection wire</li> <li>●Detect after motor stopping totally</li> <li>●Change inverter model.</li> <li>●Reset parameter according to nameplate</li> </ul>



			mistake	
	E.TE2	Motor rotation detection fault	<ul style="list-style-type: none"> <li>●Detect while motor is running</li> <li>●Detect with load</li> <li>●Detection overtime</li> <li>●Capacitance difference is too big between motor and inverter</li> <li>●Motor parameter setting mistake</li> </ul>	<ul style="list-style-type: none"> <li>●Detect after motor stop totally</li> <li>●Re-detect without load</li> <li>●Check motor connection wire</li> <li>●Change inverter model</li> <li>●Reset parameter according to nameplate</li> </ul>
	E.EEP	Memory fault	<ul style="list-style-type: none"> <li>●Electromagnetic disturb in memory period</li> <li>●EEPROM damage</li> </ul>	<ul style="list-style-type: none"> <li>●Resume load and save</li> <li>●Seek support from factory</li> </ul>
	L.iFE	Reserved		
	E.iLF	Input phase loss	<ul style="list-style-type: none"> <li>●3-phase input power open phase</li> </ul>	<ul style="list-style-type: none"> <li>●Check 3-phase power supply and the phase</li> <li>●Check 3-phase power supply wiring</li> </ul>
	E.oLF	Output phase loss	<ul style="list-style-type: none"> <li>●3-phase output power open phase</li> </ul>	<ul style="list-style-type: none"> <li>●Check 3-phase output voltage and current</li> <li>●Check wiring</li> </ul>
	E.Gnd	Output earth terminal short circuit.	<ul style="list-style-type: none"> <li>●Check wiring and insulation</li> </ul>	<ul style="list-style-type: none"> <li>●Output earth</li> </ul>
	E.HAL	Current detection fault	<ul style="list-style-type: none"> <li>●Detect circuit fault</li> <li>●Phase imbalance</li> </ul>	<ul style="list-style-type: none"> <li>●Seek support from factory</li> <li>●Check motor and wiring</li> </ul>
	E.PAn	Keyboard connect fault	<ul style="list-style-type: none"> <li>●Keyboard wire fault.</li> <li>●Keyboard component damage</li> </ul>	<ul style="list-style-type: none"> <li>●Check keyboard wire.</li> <li>●Seek support from factory</li> </ul>
	Rs485 communication fault	Unsuitable baud rate setting. Communication wire breaks. Communication format does not	<ul style="list-style-type: none"> <li>●Set suitable baud rate setting</li> <li>●Check communication wire</li> <li>●Make sure right communication format</li> </ul>	<ul style="list-style-type: none"> <li>●RS485communication fault</li> </ul>

		match upper machine.		
	E.CPE	Parameter copy fault	<ul style="list-style-type: none"> <li>●Parameter copy communication is fault</li> <li>●Copy keyboard does not match the inverter</li> </ul>	<ul style="list-style-type: none"> <li>● Check wire</li> <li>●Select the specified external keyboard model</li> </ul>
	-	Abnormal expansion card connection	<ul style="list-style-type: none"> <li>● The expansion card communicates with the inverter for timeout;</li> <li>● The expansion card does not match the drive.</li> </ul>	<ul style="list-style-type: none"> <li>● Check the connector and re-plug the cable;</li> <li>● Use the expansion card of the specified model.</li> </ul>
	27	abnormal PG card connection	<ul style="list-style-type: none"> <li>● PG card and inverter connection failure</li> </ul>	<ul style="list-style-type: none"> <li>● Check connection</li> </ul>
 	29 /66	PID feedback fault	<ul style="list-style-type: none"> <li>● PID feedback disconnection alarm upper limit is set improperly</li> <li>● PID feedback disconnection alarm lower limit is set improperly</li> <li>● Lose PID feedback wiring</li> <li>● Feedback sensor failure</li> <li>● Feedback input loop fault</li> </ul>	<ul style="list-style-type: none"> <li>● Confirm the sensor status and replace the sensor if it is damaged.</li> <li>● Correct wiring</li> <li>● Confirm the set values of F11.27 and F11.28</li> </ul>
	31	Initial position angle learning failed	<ul style="list-style-type: none"> <li>● Check motor parameters</li> </ul>	<ul style="list-style-type: none"> <li>● Check the motor parameters;</li> <li>● Learn after the motor is stationary;</li> <li>● Seek technical support from manufacturers.</li> </ul>
 	32 /70	Large Speed deviation	<ul style="list-style-type: none"> <li>●Checkout time or check level setting is unreasonable</li> <li>● Motor parameter is abnormal</li> </ul>	<ul style="list-style-type: none"> <li>● Check the motor parameters and re-learn again;</li> <li>● Check the F10.24/F10.25 parameter settings;</li> <li>● Seek technical support from manufacturers.</li> </ul>
 	33 /71	Speed protection	<ul style="list-style-type: none"> <li>● FA.27/FA.28 parameter setting is abnormal</li> <li>● Motor parameter is abnormal</li> <li>● Check the F6 group vector</li> </ul>	<ul style="list-style-type: none"> <li>● Check the motor parameters and re-learn again;</li> <li>● Check the F10.27/F10.28 parameter</li> </ul>

			control parameters	settings;
	34 /67	Load protection 1	<ul style="list-style-type: none"> <li>The checkout time or check level setting is unreasonable</li> </ul>	<ul style="list-style-type: none"> <li>Check the F10.18/F10.19 parameter settings;</li> </ul>
	35 /68	Load protection 2	<ul style="list-style-type: none"> <li>The checkout time or check level setting is unreasonable</li> </ul>	<ul style="list-style-type: none"> <li>Check the F10.20/F10.21 parameter settings;</li> </ul>
	36	CPU time out	<ul style="list-style-type: none"> <li>CPU timing timeout</li> </ul>	<ul style="list-style-type: none"> <li>Seek technical support from manufacturers.</li> </ul>
	72	GPS lock machine	<ul style="list-style-type: none"> <li>GPS timing timeout</li> </ul>	<ul style="list-style-type: none"> <li>Seek technical support from manufacturers.</li> </ul>
	73	GPS disconnection	<ul style="list-style-type: none"> <li>GPS communication disconnection</li> </ul>	<ul style="list-style-type: none"> <li>Whether the GPS expansion card is connected properly;</li> <li>GPS communication card is arrears;</li> <li>Seek technical support from manufacturers.</li> </ul>
	40	Fan short circuit	<ul style="list-style-type: none"> <li>Fan short circuit</li> </ul>	<ul style="list-style-type: none"> <li>Check if the fan is smooth</li> </ul>
	39	Motor short to ground	<ul style="list-style-type: none"> <li>Motor short circuit to ground</li> </ul>	<ul style="list-style-type: none"> <li>Check if the motor is shorted to ground</li> </ul>
A.LPn	A.LPn	Dormancy alarm	<ul style="list-style-type: none"> <li>Solar power is not enough</li> <li>Solar panel has dust or shelter</li> </ul>	<ul style="list-style-type: none"> <li>Check weather if it is cloudy</li> <li>Check and clean solar panel</li> </ul>
A.LFr	A.LFr	Low frequency alarm	<ul style="list-style-type: none"> <li>Solar power is not enough</li> <li>Running direction is wrong</li> <li>Solar panel has dust or shelter</li> </ul>	<ul style="list-style-type: none"> <li>Check weather if it is cloudy</li> <li>Check the running direction</li> <li>Check and clean solar panel</li> </ul>

A.LuT	A.LuT	Dry running alarm	The water level on the well is lower than safe level	Wait a moment and restart the pump see if the water level recovery and C00.02 is bigger than F14.17
A.oLd	A.oLd	Over current alarm	<ul style="list-style-type: none"> <li>●Acceleration time is too short</li> <li>●Pump is blocked</li> <li>●To start rotating motor</li> <li>●Motor auto-tuning is not performed</li> </ul>	<ul style="list-style-type: none"> <li>●Prolong the ACC time</li> <li>●Check the pump</li> <li>●Restart motor when it on still, or set F1.00 for 1 or 2</li> <li>●Perform motor auto tuning</li> </ul>
A.LPr	A.LPr	Minimum power alarm	<ul style="list-style-type: none"> <li>●Solar power is not enough</li> <li>●Solar panel has dust or shelter</li> </ul>	<ul style="list-style-type: none"> <li>●Check weather if it is cloudy</li> <li>●Check and clean solar panel</li> </ul>
A.Ful	A.Ful	Water full alarm	<ul style="list-style-type: none"> <li>●The water level on tank or well over the safe level</li> <li>●Level sensor is broken</li> </ul>	<ul style="list-style-type: none"> <li>●Check the water level if is higher than setting level</li> <li>●Check the level sensor</li> <li>●Check the C00.14 X terminal status if it is valid, reference page 47</li> </ul>

## Chapter 5 Parameters List

This chapter just provides function parameter table. Specifications refer to AC300 technical manual or inquiry the company.

“●” : parameter can be changed in the running state.

“○” : parameter can't be changed in the running state.

“×” : Parameter can be read only.

“ - ” : Factory setting parameter, only factory can set.

“※” : Parameter is related to the model.

### Basic parameters

NO.	Function description	Range of settings and definition		Factor y default	Feature	Address
F00.00	Motor control mode	<b>Asynchronous motor control mode:</b> 0: V/F control 3: High-performance VC without PG 4: High-performance VC with PG <b>Synchronous motor control mode:</b> 6: High-performance VC without PG 7: VC with PG <b>Other control:</b> 8: Voltage frequency separation output 1/2/5: Reserved		0	○	0x000
F00.01	Reserved					0x001
F00.02	Run command channel	0: Keyboard control 1: Terminal control	2: RS485 communication control 3: Reserved	0	●	0x002
F00.03	Frequency given source channel A	0: Keyboard number given 1: Reserved		0	●	0x003
F00.04	Frequency given source channel B	2: Voltage/Current analog AI1 given 3: Voltage/Current analog AI2 given 4: Reserved 5: Terminal pulse PUL given 6: RS485 communication given 7: Terminal UP/DW control 8: PID control given 9: Program control (PLC) given 10: Optional card 11: Multi-steps speed given		1	●	0x004
F00.05	Frequency channel B reference source	0: Max. output frequency as reference source 1: Set frequency of channel A as reference source		0	●	0x005

F00.06	Frequency given source selection	0: Channel A 1: Channel B 2: Channel A+Channel B 3: Channel A-Channel B 4: Max. value of Channel A and Channel B 5: Min. value of Channel A and Channel B	0	●	0x00 6
F00.07	Running Command Binding	<b>LED“0”digit: keyboard command instruction binding</b> <b>LED“00”digit: terminal command instruction binding</b> <b>LED“000”digit: communication command instruction binding</b> <b>LED“0000”digit: optional card command instruction binding</b> 0 : no binding 1 : keyboard number given frequency 2 : Reserved 3 : Voltage/Current analog AI1 given 4 : Voltage/Current analog AI2 given 5 : Reserved 6 : Terminal pulse PUL given 7 : RS485 communication given 8 : Terminal UP/DW control 9 : PID control given A: Program control (PLC) given B: Optional card C: Multi-steps speed given	0000	●	0x00 7
F00.08	Keyboard digital setting frequency	0~upper limit	50.00Hz z	●	0x00 8
F00.09	Max frequency output	upper limit~600.00Hz	50.00Hz z	○	0x00 9
F00.10	Upper limit frequency source selection	0: Upper limit frequency digital given 1: Reserved 2: Voltage/Current analog AI1 give 3: Voltage/Current analog AI2 given 4: Reserved 5: Terminal pulse PUL given 6: RS485 communication given 7: Optional card	0	●	0x00 A
F00.11	Upper frequency limit digital setting	Lower limit frequency~max frequency	50.00Hz z	●	0x00 B
F00.12	Lower limit frequency	0.00~upper limit frequency	0.00Hz	●	0x00 C
F00.13	Lower limit frequency running mode	0: Stop output, enter into pause running state 1: Run at lower limit frequency	1	○	0x00 D
F00.14	ACC time 1	0.01~650.00s	Model set	※	0x00 E

F00.15	DEC time 1	0.01~650.00s		Model set	※	0x00 F
F00.16	Rotary direction selection	<b>LED“0”digit: running direction takes the opposite</b> 0: Direction unchanged 1: Direction takes the opposite <b>LED“00”digit: running direction prohibited</b> 0: Forward and reverse commands are allowed 1: Only FWD command allowed 2: Only REV command allowed <b>LED“000”digit: frequency control direction selection</b> 0: Invalid      1: Valid <b>LED“0000”digit: reserved</b>		0000	○	0x01 0
F00.17	G/P Model Setting	0: G Type	1: P Type	0	●	0x01 1
F00.18	Reserved					0x01 2
F00.19	Parameter initialization	0: No action 1: Restore factory default (not restoring motor parameters) 2: Restore factory default (restoring motor parameters) 3: Clear malfunction records		0	○	0x01 3

### Operation Control Parameters Group

NO.	Function description	Range of settings and definition	Factor y setting	Featur e	Addre ss
F01.0 0	Start-up running mode	0: Start by start-up frequency 1: DC Braking at first then start by start-up frequency 2: Speed tracking, and judge the direction then start	0	○	0x100
F01.0 1	Start pre-excitation time	0.00~60.00s	0.00s	○	0x101
F01.0 2	Start-up frequency	0.00~60.00Hz	0.50Hz	○	0x102
F01.0 3	Start-up frequency holding time	0.0~50.0s	0.0s	○	0x103
F01.0 4	Braking current before start	0.0~150.0%	60.0%	○	0x104
F01.0 5	Braking time before start	0.0~60.0s	0.0s	○	0x105
F01.0 6	Speed tracking time	0.00~60.00s	0.50s	○	0x106

F01.0 7	Speed tracking delay when stop	0.00~60.00s		1.00s	○	0x107
F01.0 8	Reserved					
F01.0 9	Reserved					
F01.1 0	Stop mode	0:DEC stop	1:Free stop	0	●	0x10A
F01.1 1	DC braking initial frequency when stop	0.00~50.00Hz		1.00Hz	○	0x10B
F01.1 2	DC braking current when stop	0.0~150.0%		60.0%		0x10C
F01.1 3	Reserved					0x10D
F01.1 4	DC braking hold time when stop	0.0~60.0s		0.0s	○	0x10E
F01.1 5	Stop detection frequency	0.00~50.00Hz		0.50Hz	●	0x10F
F01.1 6	ACC/DEC selection	<b>LED “0” digit: time base selection</b> 0: max frequency 1: fixed frequency 50Hz 2: set frequency <b>LED“00”digit: S ACC/DEC selection</b> 0: Beeline ACC/DEC 1: S Curve ACC/DEC <b>LED “000” digit: reserved</b> <b>LED “0000” digit: reserved</b>		0010	○	0x110
F01.1 7	ACC start time for S curve	0.00~10.00		0.20s	○	0x111
F01.1 8	ACC end time for S curve	0.00~10.00		0.20s	○	0x112
F01.1 9	DEC start time for S curve	0.00~10.00		0.20s	○	0x113
F01.2 0	DEC end time for S curve	0.00~10.00		0.20s	○	0x114
F01.2 1	ACC time 2	0.01~650.00s		10.00s	●	0x115
F01.2 2	DEC time 2	0.01~650.00s		10.00s	●	0x116
F01.2 3	ACC time 3	0.01~650.00s		10.00s	●	0x117
F01.2 4	DEC time 3	0.01~650.00s		10.00s	●	0x118
F01.2 5	ACC time 4	0.01~650.00s		10.00s	●	0x119



F01.2 6	DEC time 4	0.01~650.00s		10.00s	●	0x11A
F01.2 7	DEC time at emergency stop	0.01~650.00s		1.00s	●	0x11B
F01.2 8	FWD&REV dead time	0.0~120.0s		0.0s	○	0x11C
F01.2 9	Zero speed torque frequency threshold	0.00~10.00Hz		0.50Hz	●	0x11D
F01.3 0	Zero speed torque holding coefficient	0.0~150.0%		60.0%	●	0x11E
F01.3 1	Zero speed torque holding time	0.0~6000.0s If set 6000.0S,always hold without time limit		0	●	0x11F
F01.3 - F01.3 4	Reserved					
F01.3 5	Power off restart action selection	0:Invalid	1:Valid	0	○	0x123
F01.3 6	Power off restart waiting time	0.00~60.00s		0.50s	○	0x124
F01.3 7	Reserved					0x125
F01.3 8	JOG running frequency setting	0.00-Max frequency		5.00Hz	●	0x126
F01.3 9	JOG ACC time	0.01~650.00s		10.00s	●	0x127
F01.4 0	JOG DEC time	0.01~650.00s		10.00s	●	0x128
F01.4 1	Jump frequency 1	0.00~Max frequency		0.00Hz	●	0x129
F01.4 2	Jump frequency range 1	0.00~Max frequency		0.00Hz	●	0x12A
F01.4 3	Jump frequency 2	0.00~Max frequency		0.00Hz	●	0x12B
F01.4 4	Jump frequency range 2	0.00~Max frequency		0.00Hz	●	0x12C

### Switching value terminal parameters

NO.	Function description	Range of setting and definition	Factor setting	Feature	Address
F02.00	Input terminal 1(X1)	Refer to function table 4.2	1	○	0x200

F02.01	Input terminal 2(X2)	Refer to function table 4.2	2	○	0x201
F02.02	Input terminal 3(X3)	Refer to function table 4.2	80	○	0x202
F02.03	Input terminal 4(X4)	Refer to function table 4.2	81	○	0x203
F02.04	Input terminal 5(X5)	Refer to function table 4.2	82	○	0x204
F02.05	Input terminal 6(X6 expand)	Refer to function table 4.2	0	○	0x205
F02.06	Input terminal 7(X7 expand)	Refer to function table 4.2	0	○	0x206
F02.07	Input terminal 8(X8 expand)	Refer to function table 4.2	0	○	0x207
F02.08	Input terminal 9(X9 expand)	Refer to function table 4.2	0	○	0x208
F02.09	Input terminal 10(X10 expand)	Refer to function table 4.2	0	○	0x209
F02.10	X1~X4 terminal trait selection	0: On valid 1: Off valid <b>LED "0" digit: X1</b> <b>LED "00" digit: X2</b> <b>LED "000" digit: X3</b> <b>LED "0000" digit: X4</b>	0000	●	0x20A
F02.11	X5~X8 terminal trait selection	0: On valid 1: Off valid <b>LED "0" digit: X5</b> <b>LED "00" digit: X6</b> <b>LED "000" digit: X7</b> <b>LED "0000" digit: X8</b>	0000	●	0x20B
F02.12	X9~X10 terminal trait selection	0: On valid 1: Off valid <b>LED "0" digit: X9</b> <b>LED "00" digit: X10</b> <b>LED "000" digit: Reserved</b> <b>LED "0000" digit: Reserved</b>	0000	●	0x20C
F02.13	X1 valid detection delay	0.000~6.000s	0.010	●	0x20D
F02.14	X1 invalid detection delay	0.000~6.000s	0.010	●	0x20E
F02.15	X2 valid detection delay	0.000~6.000s	0.010	●	0x20F
F02.16	X2 invalid detection delay	0.000~6.000s	0.010	●	0x210
F02.17	X3 valid detection delay	0.000~6.000s	0.010	●	0x211
F02.18	X3 invalid detection delay	0.000~6.000s	0.010	●	0x212
F02.19	X4 valid detection delay	0.000~6.000s	0.010	●	0x213

F02.20	X4 invalid detection delay	0.000~6.000s	0.010	●	0x214
F02.21	X5 valid detection delay	0.000~6.000s	0.010	●	0x215
F02.22	X5 invalid detection delay	0.000~6.000s	0.010	●	0x216
F02.23	Terminal control running mode	0: 2-line 1 1: 2-line 2 2: 3-line 1 3: 3-line 2	0	○	0x217
F02.24	Terminal operate protection	0: OFF 1:ON <b>LED “0” digit: Terminal operate protection when abnormal exit</b> <b>LED “00” digit: Jog terminal operate protection when abnormal exit</b> <b>LED “000” digit: Operate protection when command channel switch to terminal</b>	0111	○	0x218
F02.25	Counter input	0: Common X terminal 1: High speed input terminal PUL 2: PG card counting	0	●	0x219
F02.26	Count input frequency division	0~6000	0	●	0x21A
F02.27	PUL signal source	0: X5(max~5 KHz) 1: Extend interface X10	0	○	0x21B
F02.28	PUL input min frequency	0.00~50.00 KHz	0.00kHz	●	0x21C
F02.29	PUL min frequency corresponding setting	0.00~100.00%	0.00%	●	0x21D
F02.30	PUL input max frequency	0.00~50.00 KHz	50.00kHz	●	0x21E
F02.31	PUL max frequency corresponding setting	0.00~100.00%	100.00%	●	0x21F
F02.32	PUL filter time	0.000~9.000s	0.100s	●	0x220
F02.33	PUL cut-off frequency	0.000~1.000 KHz	0.010kHz	●	0x221
F02.34	UP/DW terminal control mode	0: Off electricity storage 1: Off electricity does not storage 2: Valid in running, clear zero at stop	0	○	0x222

F02.35	ACC/DEC speed of UP/DW terminal frequency control	0.01~50.00Hz/s	0.50Hz/s	●	0x223
F02.36	Reserved				0x224
F02.37	Timer time unit	0:Second 1:Minute 2:Hour	0	●	0x225
F02.38	Timer setting value	0~65000	0	●	0x226
F02.39	Counter max value	0~65000	1000	●	0x227
F02.40	Counter setting value	0~65000	500	●	0x228
F02.41	Reserved				0x229
F02.42	Output terminal polarity selection	0: Positive 1: Negative <b>LED “0” digit: Terminal Y</b> <b>LED “00” digit: Relay output 1</b> <b>LED “000” digit: Extended Y1 terminal</b> <b>LED “0000” digit: Extended Relay output 2</b>	0000	●	0x22A
F02.43	Output terminal Y1	Refer to function table 4.2	1	●	0x22B
F02.44	Relay output	Refer to function table 4.2	4	●	0x22C
F02.45	Extend terminal Y1	Refer to function table 4.2			0x22D
F02.46	Extend relay output 2	Refer to function table 4.2			0x22E
F02.47	Y output delay time	0.000~6.000s	0.010s	●	0x22F
F02.48	Extend Y output delay time	0.000~6.000s	0.010s	●	0x230
F02.49	Relay 1 output delay time	0.000~6.000s	0.010s	●	0x231
F02.50	Extend relay 2 output delay time	0.000~6.000s	0.010s	●	0x232
F02.51	Output frequency level 1(FDT1)	0.00~Max. frequency	30.00Hz	●	0x233
F02.52	FDT1 lag	0.00~Max. frequency	1.00Hz	●	0x234
F02.53	Output frequency level 2(FDT2)	0.00~Max. frequency	50.00Hz	●	0x235
F02.54	FDT2 lag	0.00~Max. frequency	1.00Hz	●	0x236
F02.55	Given frequency arriving checkout range	0.00~50.00Hz	2.00Hz	●	0x237
F02.60	Virtual vX1 terminal function selection	Refer to function table 4.2	0	●	0x238
F02.61	Virtual vX2	Refer to function table 4.2	0	●	0x239

	terminal function selection				
F02.62	Virtual vX3 terminal function selection	Refer to function table 4.2	0	●	0x23A
F02.63	Virtual vX4 terminal function selection	Refer to function table 4.2	0	●	0x23B
F02.64	vX terminal valid state source	0: internal connection with virtual vYn 1: Connect with physical terminal Xn 2: function code setting valid or not <b>LED “0” digit: virtual vX1</b> <b>LED “00” digit: virtual vX2</b> <b>LED “000” digit: virtual vX3</b> <b>LED “0000” digit: virtual vX4</b>	0	●	0x23C
F02.65	Virtual vX terminal function code setting valid state	0: invalid 1: valid <b>LED “0” digit: virtual vX1</b> <b>LED “00” digit: virtual vX2</b> <b>LED “000” digit: virtual vX3</b> <b>LED “0000” digit: virtual vX4</b>	0	●	0x23D
F02.66	Virtual vY1 terminal function selection	Refer to function table 4.2	0	●	0x23E
F02.67	Virtual vY2 terminal function selection	Refer to function table 4.2	0	●	0x23F
F02.68	Virtual vY3 terminal function selection	Refer to function table 4.2	0	●	0x240
F02.69	Virtual vY4 terminal function selection	Refer to function table 4.2	0	●	0x241
F02.70	Virtual vY1 output delay	0.000~6.000s	0.010	●	0x242
F02.71	Virtual vY2 output delay	0.000~6.000s	0.010	●	0x243
F02.72	Virtual vY3 output delay	0.000~6.000s	0.010	●	0x244
F02.73	Virtual vY2 output selection	0.000~6.000s	0.010	●	0x245

## Analog Terminal Parameters

NO.	Function description	Range of settings and definition	Factory setting	Feature	Address
F03.00	A11 Lower limit	0.00~10.00V	0.00V	●	0x300
F03.01	A11 Lower limit corresponding setting	-100.00~100.00%	0.00%	●	0x301
F03.02	A11 upper limit	0.00~10.00V	10.00V	●	0x302
F03.03	A11 upper limit corresponding setting	-100.00~100.00%	100.00%	●	0x303
F03.04	A11 filter time	0.000~6.000s	0.010s	●	0x304
F03.05	Reserved				
F03.06	A12 Lower limit	0.00~10.00V	0.00V	●	0x306
F03.07	A12 Lower limit corresponding setting	0.00~100.00%	0.00%	●	0x307
F03.08	A12 upper limit	0.00~10.00V	10.00V	●	0x308
F03.09	A12 upper limit corresponding setting	0.00~100.00%	100.00%	●	0x309
F03.10	A12 filter time	0.000~6.000s	0.010s	●	0x30A
F03.11	A12 zero point loop voltage	0.00~10.00V	0.00V	●	0x30B
F03.12	A11 function selection	See X terminal function	0	○	0x30C
F03.13	A11 high level setting	0.00~100.00%	70.00%	●	0x30D
F03.14	A11 low level setting	0.00~100.00%	30.00%	●	0x30E
F03.15	A12 function selection	See X terminal function	0	○	0x30F
F03.16	A12 high level setting	0.00~100.00%	70.00%	●	0x310
F03.17	A12 low level setting	0.00~100.00%	30.00%	●	0x311
F03.18	Valid state setting when	0: low level 1: high level <b>LED “0” digit: A11</b> <b>LED “00” digit: A12</b>	0000	●	0x312

	analog used as terminal	<b>LED “000” digit: reserved</b> <b>LED “0000” digit: reserved</b>			
F03.1 9	Analog input curve selection	<b>LED “0” digit: AI1</b> 0: Beeline (default) 1: curve 1 2: curve 2 <b>LED “00” digit: AI2 (Select voltage or current input by wire jumper)</b> <b>LED “000” digit: reserved</b> <b>LED “0000” digit: reserved</b>	0000	●	0x313
F03.2 0	Reserved				0x314
F03.2 1	Curve 1 lower limit	0.00~10.00V	0.00V	●	0x315
F03.2 2	Curve 1 lower limit corresponding setting	0.00~100.00%	0.0%	●	0x316
F03.2 3	Curve 1 inflection point 1 input voltage	0.00~10.00V	3.00V	●	0x317
F03.2 4	Curve 1 inflection point 1 corresponding setting	0.00~100.00%	30.00%	●	0x318
F03.2 5	Curve 1 inflection point 2 input voltage	0.00~10.00V	6.00V	●	0x319
F03.2 6	Curve 1 inflection point 2 corresponding setting	0.00~100.00%	60.00%	●	0x31A
F03.2 7	Curve 1 upper limit	0.00~10.00V	10.0V	●	0x31B
F03.2 8	Curve 1 upper limit corresponding setting	0.00~100.00%	100.00%	●	0x31C
F03.2 9	Curve 2 lower limit	0.00~10.00V	0.00V	●	0x31D
F03.3 0	Curve 2 lower limit corresponding setting	0.00~100.00%	0.00%	●	0x31E
F03.3 1	Curve 2 inflection point 1 input voltage	0.00~10.00V	3.00V	●	0x31F

F03.3 2	Curve 2 inflection point 1 corresponding setting	0.00~100.00%	30.00%	●	0x320
F03.3 3	Curve 2 inflection point 2 input voltage	0.00~10.00V	6.00V	●	0x321
F03.3 4	Curve 2 inflection point 2 corresponding setting	0.00~100.00%	60.00%	●	0x322
F03.3 5	Curve 2 upper limit	0.00~10.00V	10.00V	●	0x323
F03.3 6	Curve 2 upper limit corresponding setting	0.00~100.00%	100.00 %	●	0x324
F03.3 7	AO output signal selection	<b>LED “0” digit: AO1</b> 0: 0~10V 1: 4.00~20.00mA 2: 0.00~20.00mA 3: FM frequency pulse output <b>LED “00” digit: A02 extended card</b> 0: 0~10V 1: 4.00~20.00mA 2: 0.00~20.00mA <b>LED “000” digit: reserved</b> <b>LED 0000 digit: reserved</b>	0000	●	0x325
F03.3 8	AO output selection	0:Given frequency 1:Output frequency 2:Output current 3:Input voltage 4:Output voltage 5:Machine speed 6:Given torque 7:Output torque 8:PID given value 9:PID feedback value 10:Output power 11:Bus voltage 12:A11 13:A12 14:Reserved 15:PUL 16,17:IGBT temperature 1,2 18:RS485 given	0	●	0x326
F03.3 9	AO 2 extended output selection		1	●	0x327
F03.4 0	AO output gain	25.0~200.0%	100.0%	●	0x328



F03.4 1	AO analog output signal bias	-10.0%~10.0%	0.0%	●	0x329
F03.4 2	AO output filter	0.000~6.000s	0.010s	●	0x32A
F03.4 3	AO FM frequency output lower limit	0.00~100.00kHz	0.20kHz	●	0x32B
F03.4 4	AO2 FM frequency output upper limit	0.00~100.00kHz	50.00k Hz	●	0x32C
F03.4 5	AO2 extend output gain	25.0~200.0%	100.0%	●	0x32D
F03.4 6	AO2 extend analog output signal bias	-10.0%~10.0%	0.0%	●	0x32E
F03.4 7	AO2 extend output filter	0.000~6.000s	0.010s	●	0x32F
F03.4 8- F03.4 9	Reserved				

### System parameters

NO.	Function description	Range of settings and definition	Factory setting	Featu re	Adresse
F04.0 0	Parameter and key lock selections	0: Not locked 1: Function parameter locked 2: Function parameter and key locked (except for RUN/STOP/JOG) 3: All function parameter and key locked	0	●	0x400
F04.0 1	User password	0~65535	0	●	0x401
F04.0 2- F04.0 4	Reserved				
F04.0 5	Parameter copy	0: No function 1: Send inverter parameters to keyboard and save 2: Send keyboard parameters to inverter Remaining value: no operation	0	○	0x405
F04.0 6	Keyboard special function	<b>LED “0” digit:( Running command, stop/reset command)</b>	0000	○	0x406

	selection	<p>0: Built-in valid, external on valid for stop/reset command  1: External valid, built-in on valid for stop/reset command  2: All valid. Stop/reset command has the highest priority; invalid when FWD/REV valid at the same time</p> <p><b>LED "00" digit: reserved</b>  <b>LED "000" digit: LCD keyboard language selection</b>  0: Chinese  1: English</p>			
F04.0 7	Double line keyboard rev / jog selection	0: REV 1: JOG			0x407
F04.0 8	STOP key setting	<p>0: Non-keyboard control mode is invalid  1: Non-keyboard control mode stops according to stop mode  2: Non-keyboard control mode stop according to free stop mode</p>	1	○	0x408
F04.0 9	UP/DOWN key selection	<p><b>LED "0" digit: keyboard UN/DOWN key modify selection</b>  0: Invalid  1: Modify frequency setting by key board numbers F00.08  2: Modify PID give setting by key board numbers F11.01</p> <p><b>LED "00" digit: power off storage selection</b>  0: No save frequency after power off  1: Save frequency after power off</p> <p><b>LED "000" digit: action limit</b>  0: Operation stop for adjusting  1: Adjusting only in operation, stop for holding  2: Adjusting in operation, stop for clearing</p>	0011	○	0x409
F04.1 0- F04.1 3	Reserved				
F04.1 4	The display content of the first line in running state 1	<p><b>LED "0" and "00" digit: display the first group</b>  00~63  <b>LED "000" and "0000" digit: display the second group</b>  00~63</p>	1101	●	0x40E

F04.1 5	The display content of the first line in running state 2	Same as above	0402	●	0x40F
F04.1 6	The display content of the first line in stop state 3	Same as above	1100	●	0x410
F04.1 7	The display content of the first line in stop state 4	Same as above	0402	●	0x411
F04.1 8	The display content of the second line in running state 1	Same as above	0402	●	0x412
F04.1 9	The display content of the second line in running state 2	Same as above	1210	●	0x413
F04.2 0	The display content of the second line in stop state 3	Same as above	0402	●	0x414
F04.2 1	The display content of the second line in stop state 4	Same as above	1210	●	0x415
F04.2 2	Keyboard display item setting	<b>LED “0” digit: output frequency selection</b> 0: Aim frequency 1: Running frequency <b>LED “000” digit: power display dimension</b> 0: Power display percentage (%) 1: Power display kilowatt (KW)	0000	●	0x416
F04.2 3	Monitor display selection	<b>LED “0” digit: C00.00-C00.39</b> 0: Normal 1: Debugging <b>LED “00” digit: C00.40-C00.69</b> 0: No display 1: Normal display	0000	●	0x417
F04.2 4	Rotate speed display coefficient	0.0~500.0%	0000	●	0x418
F04.2 5	Power display coefficient	0.0~500.0%	100.0%	●	0x419
F04.2 6	Alarm selection 1	<b>LED “0” digit: E.EEP fault (EEPROM storage fault)</b> 0: Alarm and free stop 1: Alarm and continue operation	100.0%	●	0x41A

F04.2 7	Reserved			0000	○	0x41B
F04.2 8	Fan control	0: After power on the fan runs 1: Stop associated with temperature, running is rotary 2: Running associated with temperature, stop while the fan stops		1	●	0x41C
F04.2 9	Energy braking enable	0: Off	1: On	0	●	0x41D
F04.3 0	Energy braking operation voltage	115.0%~140.0%		125.0%	●	0x41E
F04.3 1	Reserved					
F04.3 2	PWM carrier frequency	0.7~16.0kHz		Model set	※	0x420
F04.3 3	PWM control mode	<b>LED “0” digit: carrier associated with temperature</b> 0: Temperature independent 1: Temperature dependent <b>LED “00” digit : carrier associated with output frequency</b> 0: not associated      1: associated <b>LED “000” digit: random PWM valid</b> 0: Prohibited          1: Valid <b>LED “0000” digit: PWM modulation mode</b> 0: Only use three-phase modulation 1: Two-phase and three-phase modulation automatically switched		1111	●	0x421

**Motor Parameters**

NO.	Function description	Range of settings and definition	Factor y default	Feature	Addresses
F05.00	Motor mode	0: Asynchronous motors (AM) 1: Permanent magnet synchronous motors (PM)	0	×	0x500
F05.01	Number of motor poles	2~98	4	○	0x501
F05.02	Motor rated power	0.1~1000.0kW	Model set	※	0x502
F05.03	Motor rated frequency	0.01~max frequency	Model set	※	0x503
F05.04	Motor rated speed	1~6500rpm	Model set	※	0x504
F05.05	Motor rated voltage	1~1500V	Model set	※	0x505
F05.06	Motor rated current	0.1~3000.0A	Model set	※	0x506
F05.07	Asynchronous motor no-load current	0.1~3000.0A	Model set	※	0x507
F05.08	Asynchronous motor stator resistance	0.01~50.00%	Model set	※	0x508
F05.09	Asynchronous motor rotor resistance	0.01~50.00%	Model set	※	0x509
F05.10	Asynchronous motor stator leakage inductance	0.01~50.00%	Model set	※	0x50A
F05.11	Asynchronous motor stator inductance	0.1~2000.0%	Model set	※	0x50B
F05.12	synchronous motor stator resistance	0.01~50.00%	Model set	※	0x50C
F05.13	Synchronous machine d axis inductance	0.01~200.00%	Model set	※	0x50D
F05.14	Synchronous machine q axis inductance	0.01~200.00%	Model set	※	0x50E
F05.15	Synchronous machine back EMF	1~1500V	Model set	※	0x50F

F05.16	Synchronous machine encoder installation angle	0.0°~360.0°	Model set	※	0x510
F05.17-F05.19	Reserved				
F05.20	Motor parameters self-adjustment selections	0: No operation 1: Rotary type self-tuning 2: Static type self-tuning 3: Stator resistance self-tuning	0	○	0x514
F05.21	Synchronous machine poles searching function	<b>LED “0” digit: closed-loop vector</b> 0: OFF 1: ON 2: On, only operate firstly when electrify <b>LED “00” digit: open-loop vector</b> 0: OFF 1: ON 2: ON, only operate firstly when electrify	0010	○	0x515
F05.22-F05.29	Reserved				
F05.30	Speed feedback or encoder mode	<b>LED “0” digit: encoder mode</b> 0: Common ABZ encoder 1: Resolver encoder <b>LED “00” digit: encoder direction</b> 0: same direction 1: reverse direction <b>LED “000” digit: wire break inspection</b> 0: OFF 1: ON <b>LED“0000”digit:Z pulse correction enabled</b> 0: OFF 1: ON	0000	○	0x51E
F05.31	ABZ encoder lines	0-10000	1024	○	0x51F
F05.32	Wire break inspection time	0.100-60.000s	2.000s	●	0x520
F05.33	Resolver encoder poles	2~128	2	○	0x521
F05.34	Numerator of encoder transmission ratio	1~32767	1	○	0x522
F05.35	Denominator of encoder	1~32767	1	○	0x523

	transmission ratio				
F05.36	First-order filter of encoder speed inspection	0.0~100.0ms	1.0ms	●	0x524
F05.39	PG feedback monitoring selection	LED "0" digit: C00.29 monitoring PG feedback speed 0: invalid 1: valid			
F05.40- F05.49	Reserved				

### Motor VC Parameters

NO.	Function description	Range of settings and definition	Factor y default	Featur e	Address s
F06.00	ASR(speed loop) proportional gain 1	0.01~100.00	10.00	●	0x600
F06.01	ASR integral time 1	0.000~6.000s	0.200s	●	0x601
F06.02	ASR filter time1	0.0~100.0ms	0.0ms	●	0x602
F06.03	ASR switch frequency 1	0.00~Max frequency	0.00Hz	●	0x603
F06.04	ASR (speed loop) proportional gain 2	0.01~100.00	10.00	●	0x604
F06.05	ASR (speed loop) integral time 2	0.000~6.000s	0.200s	●	0x605
F06.06	ASR filter time 2	0.0~100.0ms	0.0ms	●	0x606
F06.07	ASR switch frequency 2	0.00~Max frequency	5.00Hz	●	0x607
F06.08	Electric motor torque limit	0.0~250.0%	180.0%	●	0x608
F06.09	Power generation torque limit	0.0~250.0%	180.0%	●	0x609
F06.10	Current loop D-axis proportional gain	0.001~4.000	1.000	●	0x60A
F06.11	Current loop D-axis integral gain	0.001~4.000	1.000	●	0x60B
F06.12	Current loop Q-axis proportional gain	0.001~4.000	1.000	●	0x60C

F06.13	Current loop Q-axis integral gain	0.001~4.000	1.000	●	0x60D
F06.15	Vector control motor slip compensation	0.0~250.0%	100.0%	●	0x60F
F06.16- F06.17	Reserved		0	○	0x612
F06.18	Position compensation control	0:OFF 1:ON	10.0%	○	0x613
F06.19	Compensation gain	0.0~250.0%	0.1%	○	0x614
F06.20	Compensation limit	0.0~100.0%	10.0%	○	0x615
F06.21	Compensation effective range	0.0~100.0%	100.0%	○	0x616
F06.22	Over excitation braking gain	0.0~500.0%	100.0%	○	0x617
F06.23	Over excitation braking amplitude limit	0.0~250.0%	0	○	0x618
F06.24	Vector control energy saving function	0:OFF 1:ON	50.0%	●	0x619
F06.25	Energy saving control gain	0.0~80.0%	0.010s	●	0x61A
F06.26	Energy saving control low-pass filter	0.000~6.000s	200.0%	●	0x61B
F06.27	Motor constant power area power limit	0.0~250.0%	60.0%	○	0x61C
F06.28	Motor weak magnetic current upper limit	0.0~250.0%	10.0%	●	0x61D
F06.29	Motor weak magnetic feed forward gain	0.0~200.0%	10.0%	●	0x61E
F06.30	Motor weak magnetic gain	0.0~500.0%	10.0%	●	0x620
F06.32	MTPA gain	0.0~500.0%	100.0%	●	0x621
F06.33	MTPA filter time	0.0~100.0ms	1.0ms	●	0x621
F06.34	Reserved				0x622



F06.35	Low frequency pull in current	0.0~100.0%	10.0%	●	0x623
F06.36	High frequency pull in current	0.0~100.0%	10.0%	●	0x624
F06.37	Frequency of current pulled in	0.0~100.0%	10.0%	●	0x625
F06.38-F06.69	Reserved				

### Torque Control Parameters

NO.	Function description	Range of settings and definition		Factor y default	Featur e	Addres s
F07.00	Torque/Speed control	0:Speed control 1:Torque control Torque/Speed control		0	●	0x700
F07.01	Torque given channels selection	0: keyboard number given 1: reserved 2: AI1 3: AI2	4: reserved 5: PUL 6: RS485 communication given 7: Optional card	0	●	0x701
F07.02	Torque keyboard number setting	0~100.0%		0.0%	●	0x702
F07.03	Torque input lower limit	0~100.00%		0.00%	●	0x703
F07.04	Lower limit corresponding setting	-200.00%~200.00%		0.00%	●	0x704
F07.05	Torque input upper limit	0~100.00%		100.00 %	●	0x705
F07.06	Upper limit corresponding setting	-200.00%~200.00%		100.00 %	●	0x706
F07.07	Given first-order filter time	0.000~6.000S		0.100s	●	0x707
F07.08	Output torque upper limit	0~200.0%		150.0%	●	0x708
F07.09	Output torque	0~200.0%		0%	●	0x709

	lower limit				
F07.10	Torque control FWD speed limit selection	0: function code F07.12setting 1: reserved 2:AI1 × F07.12 3: AI2 × F07.12 4: reserved 5:PUL × F07.12 6: RS485 communication given × F07.12 7: Optional card × F07.12	0	●	0x70A
F07.11	Torque control REV speed limit selection	0: function code F07.13setting 1: reserved 2:AI1 × F07.13 3: AI2 × F07.13 4: reserved 5:PUL × F07.13 6: RS485 communication given × F07.13 7: Optional card × F07.13	0	●	0x70B
F07.12	Torque control FWD max speed limit	0.0~100.0%	100.0%	●	0x70C
F07.13	Torque control REV max speed limit	0.0~100.0%	100.0%	●	0x70D

### Motor V/F Control Parameter

NO.	Function description	Range of settings and definition	Factor y default	Featur e	Address
F08.00	Linear V/F curve selection	0: Beeline VF curve 1-9: 1.1-1.9 th power VF curve respectively 10: square VF curve 11: self-defined VF curve	0	○	0x800
F08.01	Self-setting voltage V1	0.0~100.0%	3.0%	○	0x801
F08.02	Self-setting frequency F1	0.00~max frequency	1.00Hz	○	0x802
F08.03	Self-setting voltage V2	0.0~100.0%	28.0%	○	0x803
F08.04	Self-setting frequency F2	0.00~max frequency	10.00H z	○	0x804
F08.05	Self-setting voltage V3	0.0~100.0%	55.0%	○	0x805
F08.06	Self-setting frequency F3	0.00~max frequency	25.00H z	○	0x806
F08.07	Self-setting voltage V4	0.0~100.0%	78.0%	○	0x807

F08.08	Self-setting frequency F4	0.00~max frequency		37.50Hz z	○	0x808
F08.09	Self-setting voltage V5	0.0~100.0%		100.0%	○	0x809
F08.10	Self-setting frequency F5	0.00~max frequency		50.00Hz z	○	0x80A
F08.11	Output voltage percentage	25.0~120.0%		100.0%	○	0x80B
F08.12	Torque boost	0.0~30.0%		0.0%	●	0x80C
F08.13	Torque boost cut-off frequency	0.0~100.0%		100.0%	●	0x80D
F08.14	Slip compensation gain	0.0~200.0%		100.0%	●	0x80E
F08.15	Slip compensation limit	0.0~300.0%		100.0%	●	0x80F
F08.16	Slip compensation filter time	0.000~6.000s		0.200s	●	0x810
F08.17	Oscillation suppression gain	0.0~900.0%		100.0%	●	0x811
F08.19	Auto energy saving control	0: off	1:on	0	○	0x813
F08.20	Energy saving lower limit frequency	0.0~50.00Hz		15.00Hz z	○	0x814
F08.21	Energy saving lower limit voltage	20.0~100.0%		50.0%	○	0x815
F08.22	Energy saving regulation rate of voltage	0.000~0.200V/MS		0.010V/ MS	●	0x816
F08.23	Energy saving recovery rate of voltage	0.000~2.000V/MS		0.200V/ MS	●	0x817
F08.24 - F08.34	Reserved					

### Protection and Malfunction Parameter Group

NO.	Function description	Range of settings and definition	Factory default	Feature	Addresses
F10.00	OC suppression function	0: Suppression valid 1: ACC/DEC valid, constant speed invalid	0	●	0xA00
F10.01	OC suppression point	0.0~300.0%	160.0%	●	0xA01
F10.02	OC suppression gain	0.0~500.0%	100.0%	●	0xA02
F10.03	Current hardware protection settings	<b>LED“0” digit: CBC(cycle by cycle, limit current according to its waveform)</b> 0: off 1: on <b>LED“00” digit: OC protection interference suppression</b> 0: off 1: First grade 2: Second grade <b>LED“000”digit: SC protection interference suppression</b> 0: off 1: First grade 2: Second grade <b>LED“0000”digit: Reserved</b>	0001	○	0xA03
F10.04	Reserved				
F10.05	Reserved				
F10.06	Bus over voltage suppression function	<b>LED“0” digit: Over voltage suppression</b> 0: Invalid 1: Valid in DEC 2: Valid both in ACC/DEC <b>LED“00” digit: Over-excitation control</b> 0: off 1: on <b>LED“000”/“0000”: Reserved</b>	0012	○	0xA06
F10.07	Bus over voltage suppression point	T3: 650-780v (default 750) T2 / S2: 340-380v (default 365)	Model set	※	0xA07
F10.08	Bus over voltage suppression gain	0.0~500.0%	100.0%	●	0xA08
F10.09	Bus under voltage suppression function	0: Invalid 1: Valid	0	○	0xA09
F10.10	Bus under voltage suppression point	T3: 350-450v (default 430) T2 / S2: 180-260v (default 240)	Model set	※	0xA0A
F10.11	Bus under voltage suppression gain	0.0~500.0%	100.0%	●	0xA0B
F10.12	Bus under voltage protection point	T3: 300-400v (default 320) T2 / S2: 160-240v (default 190)	Model set	※	0xA0C

F10.13	Phase missing threshold	0~30%	10.0%	○	0xA0D
F10.14	Short-circuit detection after power on	<b>LED “0” digit: Earth short-circuit detection after power on</b> 0: off 1: on 2: Check every operation <b>LED”00” digit: Fan short-circuit detection after power</b> 0: off 1: on	11	○	0xA0E
F10.15	Phase missing protection	<b>LED“0” digit: Output phase missing protection</b> 0: off 1: on <b>LED“00” digit: Input phase missing protection</b> 0: off 1: Open Alarm 2: Open Fault (STOP VFD) <b>LED“000” /“0000” digit: Reserved</b>	0021	○	0xA0F
F10.16	Motor overload protection curve	0.0~250.0%	100.0%	○	0xA10
F10.17	Load pre alarm detection setting	<b>LED“0” digit: Detection selection(Protection 1)</b> 0: Not detection 1: Detected load is too large 2: Detected load is too large only at constant speed 3: Detected underloaded 4: Detected underloaded only at constant speed <b>LED”00” digit: Alarm selection</b> 0: alarm and continue operation 1: Fault protection and free stop <b>LED”000” digit: Detection selection (Protection 2)</b> 0: Not detection 1: Detected load is too large 2: Detected load is too large only at constant speed 3: Detected underloaded 4: Detected underloaded only at constant speed <b>LED “0000” digit: Alarm selection</b> 0: Alarm and continue operation 1: Fault warn and free stop	0000	○	0xA11
F10.18	Pre alarm detection level 1 for load	0.0~200.0%	130.0%	○	0xA12
F10.19	Load pre alarm detection time 1	0.0~60.0s	5.0s	○	0xA13

F10.20	Pre alarm detection level 2 for load	.0~200.0%	30.0%	○	0xA14
F10.21	Load pre alarm detection time 2	0.0~60.0s	5.0s	○	0xA15
F10.22	Reserved				0xA16
F10.23	Protection action of speed bias excess	<b>LED “0” digit: Detection selection</b> 0: Not detected 1: Detected only at constant speed 2: Detecting <b>LED “00” digit: Alarm selection</b> 0: Free stop and report fault 1: Alarm and continue operation <b>LED “000”/”0000” digit: Reserved</b>	0000	○	0xA17
F10.24	Detection threshold when speed bias excess	0.0~60.0%	10.0%	○	0xA18
F10.25	Detection time when speed bias excess	0.0~60.0s	2.0s	○	0xA19
F10.26	Stall protection action	<b>LED “0” digit: Detection selection</b> 0: Not detected 1: Detected at constant speed 2: Detecting <b>LED “00” digit: Alarm selection</b> 0: Free stop and report fault 1: Alarm and continue operation <b>LED “000” digit: Reserved</b> <b>LED “0000” digit: Reserved</b>	0000	○	0xA1A
F10.27	Stall detection threshold	0.0~150.0%	110.0%	○	0xA1B
F10.28	Stall detection time	0.000~2.000s	0.010s	○	0xA1C
F10.29	Motor overheat protection selection (extension)	<b>LED “0” digit: temperature detection type selection</b> 0: PT1000 1: KTY84 (PT100 is preferred by the section switch)		○	0xA1D
F10.30	Motor overheat threshold (extend)	0~200°C (fault E.oH3 is reported when the threshold value is exceeded)		○	0xA1E
F10.31	Motor overheat pre-alarm threshold (extended)	0.0~200.0 °C (exceeded the threshold pre-alarm A.oH3)	90.0	○	0xA1F
F10.32-F10.34	Reserved				

F10.35	Starting threshold of motor overload	100%-130%	110	○	0XA23
F10.36	Motor overload current coefficient	0-250%	100	○	0XA24
F10.37	Reserved				
F10.38	Malfunction self-recovery times	0~5	0	○	0xA26
F10.39	Malfunction self-recovery interval time	0.1~100.0s	1.0s	○	0xA27

### PID Process Control Parameter Group

NO.	Function description	Range of settings and definition		Factor y default	Feature	Address
F11.00	PID Controller given signal source	0: Keypad digit 1: Reserved 2: AI1 3: AI2 4: Reserved	5: PUL 6: RS485 7: Option card 8: Terminal selection	0	●	0xB00
F11.01	Keyboard digit PID given / feedback	0.00~100.0%		50.0%	●	0xB01
F11.02	PID given changing time	0.00~60.00s		1.00s	●	0xB02
F11.03	PID controller feedback signal source	0: Keypad digital PID feedback 1: Reserved 2: AI1 3: AI2	4: Reserved 5: PUL 6: RS485 7: Option card 8: Terminal selection	2	●	0xB03
F11.04	Feedback signal filter time	0.000~6.000s		0.010s	●	0xB04
F11.05	Feedback signal gain	0.00~10.00		1.00	●	0xB05
F11.06	Given and feedback range	0~100.0		100.0	●	0xB06
F11.07	PID control selection	<b>LED"0" digit: Feedback feature selection</b> 0: Positive feature    1: Negative feature <b>LED"00"/"000" digit: Reserved</b> <b>LED"0000" digit: Differential adjustment properties</b> 0: Differential of bias		0100	●	0xB07

		1: Differential of feedback			
F11.08	PID preset output	0.0~100.0%	100.0%	●	0xB08
F11.09	PID preset output running time	0.0~6500.0s	0.0s	●	0xB09
F11.10	PID control deviation limit	0.0~100.0%	0.0%	●	0xB0A
F11.11	Proportional gain P1	0.000~8.000	0.100	●	0xB0B
F11.12	Integral time I1	0.0~600.0s	1.0s	●	0xB0C
F11.13	Differential time D1	0.000~6.000s	0.000s	●	0xB0D
F11.14	Proportional gain P2	0.000~8.000	0.100	●	0xB0E
F11.15	Integral time I2	0.0~600.0s	1.0s	●	0xB0F
F11.16	Differential gain D2	0.000~6.000s	0.000s	●	0xB10
F11.17	PID Parameter switching condition	0: No switch 1: Use DI terminal to switch 2: Switch according to deviation	0	●	0xB11
F11.18	Low value of switching deviation	0.0~100.0%	20.0%	●	0xB12
F11.19	High value of switching deviation	0.0~100.0%	80.0%	●	0xB13
F11.20	Reserved				0xB14
F11.21	Differential limit	0.0~100.0%	5.0%	●	0xB15
F11.22	PID output upper limit	0.0~100.0%	100.0%	●	0xB16
F11.23	PID output lower limit	-100.0~F11.22	0.0%	●	0xB17
F11.24	PID output filter time	0.000~6.000s	0.000s	●	0xB18
F11.25	Feedback wire break detection time	0.0~120.0s	1.0s	●	0xB19
F11.26	Feedback wire break action selection	0: Go on PID operation without alarm 1: Stop and alarm malfunction 2: continue to PID operation and output alarm signal 3: Run at the current frequency and output alarm signal	0	●	0xB1A
F11.27	Wire break alarm upper limit	0.0~100.0%	100.0%	●	0xB1B



F11.28	Wire break alarm lower limit	0.0~100.0%	0.0%	●	0xB1C
F11.29	Sleep selection	0: close 1: valid	0	●	0xB1D
F11.30	Sleep frequency	0.00~50.00Hz	10Hz	●	0xB1E
F11.31	Sleep delay	0.0~3600.0S	60.0	●	0xB1F
F11.32	Wakeup bias	0.0~50.0%	5.0%	●	0xB20
F11.33	Wakeup delay	0.0~60.0S	1.0	●	0xB21

### Multi-Speed and PLC Function Parameter Group

NO.	Function description	Range of setting and definition	Factory default	Feature	Address
F12.00	PLC Speed 1	0.00~Max frequency	10.00Hz	●	0xC00
F12.01	PLC Speed 2	0.00~Max frequency	20.00Hz	●	0xC01
F12.02	PLC Speed 3	0.00~Max frequency	30.00Hz	●	0xC02
F12.03	PLC Speed 4	0.00~Max frequency	40.00Hz	●	0xC03
F12.04	PLC Speed 5	0.00~Max frequency	50.00Hz	●	0xC04
F12.05	PLC Speed 6	0.00~Max frequency	40.00Hz	●	0xC05
F12.06	PLC Speed 7	0.00~Max frequency	30.00Hz	●	0xC06
F12.23	PLC Speed 8	0.00~Max frequency	20.00Hz	●	0xC07
F12.08	PLC Speed 9	0.00~Max frequency	10.00Hz	●	0xC08
F12.09	PLC Speed 10	0.00~Max frequency	20.00Hz	●	0xC09
F12.10	PLC Speed 11	0.00~Max frequency	30.00Hz	●	0xC0A
F12.11	PLC Speed 12	0.00~Max frequency	40.00Hz	●	0xC0B
F12.12	PLC Speed 13	0.00~Max frequency	50.00Hz	●	0xC0C
F12.13	PLC Speed 14	0.00~Max frequency	40.00Hz	●	0xC0D
F12.14	PLC Speed 15	0.00~Max frequency	30.00Hz	●	0xC0E
F12.15	PLC Running mode selection	<b>LED"0" digit: cycle mode</b> 0: Stop after single cycle 1: Continuous cycles 2: Keep final value after single cycle <b>LED"00" digit: Time unit</b> 0: second 1: minute 2: hour <b>LED"000" digit: Power down memory</b> 0: Not save 1: save <b>LED"0000" digit: Start mode</b> 0: Restart from the 1st stage 1: Restart from the stop stage 2: Continue running from the time when stop	0000	●	0xC0F
F12.16	PLC 1st step running time	0.0~6500.0(s/m/h)	10.0	●	0xC10
F12.17	PLC 2nd step running time	0.0~6500.0(s/m/h)	10.0	●	0xC11

F12.18	PLC 3rd step running time	0.0~6500.0(s/m/h)		10.0	●	0xC12
F12.19	PLC 4thstep running time	0.0~6500.0(s/m/h)		10.0	●	0xC13
F12.20	PLC 5th step running time	0.0~6500.0(s/m/h)		10.0	●	0xC14
F12.21	PLC 6th step running time	0.0~6500.0(s/m/h)		10.0	●	0xC15
F12.22	PLC 7th step running time	0.0~6500.0(s/m/h)		10.0	●	0xC16
F12.23	PLC 8th step running time	0.0~6500.0(s/m/h)		10.0	●	0xC17
F12.24	PLC 9th step running time	0.0~6500.0(s/m/h)		10.0	●	0xC18
F12.25	PLC 10th step running time	0.0~6500.0(s/m/h)		10.0	●	0xC19
F12.26	PLC 11th step running time	0.0~6500.0(s/m/h)		10.0	●	0xC1A
F12.27	PLC 12th step running time	0.0~6500.0(s/m/h)		10.0	●	0xC1B
F12.28	PLC 13th step running time	0.0~6500.0(s/m/h)		10.0	●	0xC1C
F12.29	PLC 14th step running time	0.0~6500.0(s/m/h)		10.0	●	0xC1D
F12.30	PLC 15th step running time	0.0~6500.0(s/m/h)		10.0	●	0xC1E
F12.31	PLC 1st-15th step direction and ADD/DEC time	<b>LED"0" digit: current step run direction</b> 0: FWD 1: REV <b>LED"00" digit: ACC/DEC time in this step</b> 0: ACC/DEC time 1 1: ACC/DEC time 2 2: ACC/DEC time 3 3: ACC/DEC time 4 <b>LED"000" digit: Reserved</b> <b>LED"0000" digit: Reserved</b>		0000	●	0xC1F
F12.32				0000	●	0xC20
F12.33				0000	●	0xC21
F12.34				0000	●	0xC22
F12.35				0000	●	0xC23
F12.36				0000	●	0xC24
F12.37				0000	●	0xC25
F12.38				0000	●	0xC26
F12.39				0000	●	0xC27
F12.40				0000	●	0xC28
F12.41				0000	●	0xC29
F12.42				0000	●	0xC2A
F12.43				0000	●	0xC2B
F12.44				0000	●	0xC2C
F12.45				0000	●	0xC2D
F12.46- F12.48	Reserved					
F12.49	Swing frequency control	0: invalid	1: valid	0	●	0xC31
F12.50	Swing frequency amplitude	0: Relative to central frequency 1: Relative to max frequency		0	●	0xC32

F12.51	Reserved				
F12.52	Swing frequency amplitude	0.0~100.0%	10.0%	●	0xC34
F12.53	Jump frequency amplitude	0.0~50.0%	10.0%	●	0xC35
F12.54	Swing frequency rising time	0.00~650.00s	5.00s	●	0xC36
F12.55	Swing frequency falling time	0.00~650.00s	5.00s	●	0xC37

### Communication Control Function Parameter Group

NO.	Function description	Range of setting and definition		Factor y default	Featur e	Address
F13.00	Main-slave machine selection	<b>LED “0” digit: Modbus main-slave selection</b> 0: Slave machine 1: Main machine <b>LED “00” /“000”/“0000” digit: reserved</b>		0000	○	0xD00
F13.01	485 communication address	1~247		1	○	0xD01
F13.02	Communication baud rate selection	<b>LED“0” digit:485 communication</b> 0:1200 bps                      1:2400 bps 2:4800 bps                      3:9600 bps 4:19200 bps                      5:38400 bps <b>LED “00” /“000”/“0000” digit: reserved</b>		0003	○	0xD02
F13.03	Modbus data format	0: (N,8,1) format 1: (E,8,1) format 2: (O,8,1) format	3: (N,8,2) format 4: (E,8,2) format 5: (O,8,2)format	0	○	0xD03
F13.04	Communication ratio setting	0.00~5.00		1.00	●	0xD04
F13.05	Modbus communication answer delay	0~500ms		0ms	●	0xD05
F13.06	Modbus communication overtime fault time	0.1~100.0s		1.0s	●	0xD06

F13.07	Modbus communication fault action mode selection	0: No checked overtime fault 1: alarm and stop freely 2: Alarm and continue running 3: Forced stop	0	●	0xD07
F13.08	Modbus Responds dispose	0: Write operation with response 1: Write operation without response	0	●	0xD08
F13.09	Main machine sending selection	<b>LED“0”digit: the first group transmitting frame selection</b> 0: Invalid 1: Main machine run command 2: Main machine given frequency 3: Main machine output frequency 4: Main machine upper limit frequency 5: Main machine given torque 6: Main machine output torque 7/8: Reserved 9: Main machine given PID A: Main machine feedback PID <b>LED“00”digit: the second group transmitting frame selection</b> <b>LED“000”digit: the third group transmitting frame selection</b> <b>LED“0000”digit: the fourth group transmitting frame selection</b> Same as above	0031	●	0xD09
F13.10	RS485 Communication port configuration	0: Modbus communication 1: serial port communication	0	●	0xD0A
F13.11 - F13.15	Reserved				
F13.16	Extension port communication disconnection processing	<b>LED“0”digit: EX-A port disconnection action mode</b> 0: no detection 1: Alarm and free stop 2: Warn and continue <b>LED“00”digit: EX-B port disconnection action mode</b> 0: no detection 1: Alarm and free stop 2: Warn and continue	0000	●	0xD10
F13.17	Expansion port EX-A parameter update	0: no update 1: The initial value has been updated after power on		○	0xD11

		2: EX-A parameter returns to initial value			
F13.18	Expansion port EX-B parameter update	0: no update 1: The initial value has been updated after power on 2: EX-A parameter returns to initial value		○	0xD12
F13.19	Expansion port EX-A monitoring frame address group 1	<b>LED“0” and “00”digit: address lower 8 bits</b> 00~63 <b>LED“000” and “0000”digit: address higher 8 bits</b> 00~07	0001	●	0xD13

## Photovoltaic Pump Special Parameters

Function code	Function name	Setting range and definition	Default setting	property	Comm Add
F14.00	Solar pump drive control mode	<b>LED“0” digit:Mode Selection</b> 0: Variable frequency control mode 1: CVT mode for solar 2: MPPT mode for solar <b>LED“00” digit:Operation Selection</b> 0 :Normal operation 1: Intermittent operation 2: Pump cleaning <b>LED“000” digit:Reserved</b> <b>LED“0000” digit:Motor Selection</b> 0: Three-phase motor 1: Single-phase motor	0002	○	0xE00
F14.01	Running control mode	0: Stop 1: Running 2: Sleep 3: Low speed protection 4: Dry run protection 5: Over current protection 6: Minimum power protection 7: Water fulfilled	Read only		0xE01
F14.02	VOC voltage (display)	0.0V ~ 999.9V	Read only		0xE02
F14.03	CVT target voltage	70.0% ~ 95.0%	81.0%	●	0xE03
F14.04	MPPT upper limit voltage	20.0% ~ 200.0%	100.0 %	●	0xE04
F14.05	MPPT lower limit voltage	20.0% ~ 200.0%	50.0%	●	0xE05
F14.06	Frequency adjusting gain	0.1% ~ 500.0%	10.0% (AM) 40.0%	●	0xE06

			(PMSM)		
F14.07	MPPT search interval	0.1s ~ 100.0s	1.0s	●	0xE07
F14.08	MPPT regulating gain	0 ~ 9999	100	●	0xE08
F14.09	Quick-drop frequency gain	0 ~ 20	2	●	0xE09
F14.10	Frequency adjusting filter time	0.001s ~ 2.000s	0.001s	●	0xE0A
F14.11	Go to sleep mode voltage	0V ~ 1000V	0V	●	0xE0B
F14.12	Wake up restore voltage	0V ~ 1000V	400V	●	0xE0C
F14.13	Sleeping stop restore waiting time	0.0s ~ 3000.0s	10.0s	●	0xE0D
F14.14	Low speed protection detect frequency	0.00Hz ~ 300.00Hz	10.00Hz	●	0xE0E
F14.15	Low speed protection detect time	0.0s ~ 3000.0s	10.0s	●	0xE0F
F14.16	Low speed protection restore working time	0.0s ~ 3000.0s	10.0s	●	0xE10
F14.17	Dry run protection detect current	0.0A ~ 999.9A	0.0A	●	0xE11
F14.18	Dry run protection detect time	0.0s ~ 3000.0s	10.0s	●	0xE12
F14.19	Dry run auto restore working time	0.0s ~ 3000.0s	10.0s	●	0xE13
F14.20	Over current point setting	0.0A ~ 999.9A	0.0A	●	0xE14
F14.21	Over current protection detect time	0.0s ~ 3000.0s	10.0s	●	0xE15
F14.22	Over current protection auto restore working time	0.0s ~ 3000.0s	10.0s	●	0xE16
F14.23	Input minimum power protection power point setting	0.00kW ~ 650.00kW	0.00kW	●	0xE17
F14.24	Minimum power protection detect time	0.0s ~ 3000.0s	10.0s	●	0xE18
F14.25	Minimum power protection auto restore working time	0.0s ~ 3000.0s	10.0s	●	0xE19
F14.26	Fault alarm restore mode	0: Auto reset;1:Reset by manual LED0:Low speed protection LED1:Dry run LED2:Over current protection LED3: Minimum power protection	0000	●	0xE1A
F14.27	Water fulfilled detect time	0.0s ~ 3000.0s	10.0s	●	0xE1B
F14.28	Water fulfilled restore time	0.0s ~ 3000.0s	10.0s	●	0xE1C
F14.29	Reserve	<b>LED"0" digit:Reserved</b> <b>LED"00" digit:Reserved</b> <b>LED"000" digit:Reserved</b> <b>LED"0000" digit:Dry Run Selection</b>		●	0xE1D

		0.Sensorless 1.External Sensor			
F14.30	DC current revise offset	0.00A ~ 99.99A	0.01A	●	0xE1E
F14.31	DC current revise proportion gain	0.0% ~ 999.9%	100.0 %	●	0xE1F
F14.32	Power curve point 0	0.00kW ~ 99.99kW	0.50k W	●	0xE20
F14.33	Power curve point 1	0.00kW ~ 99.99kW	1.00k W	●	0xE21
F14.34	Power curve point 2	0.00kW ~ 99.99kW	1.50k W	●	0xE22
F14.35	Power curve point 3	0.00kW ~ 99.99kW	2.00k W	●	0xE23
F14.36	Power curve point 4	0.00kW ~ 99.99kW	2.50k W	●	0xE24
F14.37	Flow curve point 0	0.0 m <sup>3</sup> /h ~ 999.9 m <sup>3</sup> /h	0.0m <sup>3</sup> /h	●	0xE25
F14.38	Flow curve point 1	0.0 m <sup>3</sup> /h ~ 999.9 m <sup>3</sup> /h	5.0m <sup>3</sup> /h	●	0xE26
F14.39	Flow curve point 2	0.0 m <sup>3</sup> /h ~ 999.9 m <sup>3</sup> /h	10.0m <sup>3</sup> /h	●	0xE27
F14.40	Flow curve point 3	0.0 m <sup>3</sup> /h ~ 999.9 m <sup>3</sup> /h	15.0m <sup>3</sup> /h	●	0xE28
F14.41	Flow curve point 4	0.0 m <sup>3</sup> /h ~ 999.9 m <sup>3</sup> /h	20.0m <sup>3</sup> /h	●	0xE29
F14.42	Flow calculating revise offset	0.0 m <sup>3</sup> ~ 999.9 m <sup>3</sup>	0.0 m <sup>3</sup>	●	0xE2A
F14.43	Flow calculating revise gain	0.0% ~ 999.9%	100.0 %	●	0xE2B
F14.44	Power per day/ generated power per day reset period	0.0h ~ 24.0h	7.0h	●	0xE2C
F14.45	Reserved				0xE2D
F14.46	Photovoltaic pump function selection 1	0:Invalid 1:Valid LED0:Constant torque frequency limit selection LED1:Reserved LED2:Voltage rising update Voc voltage LED3: Fast frequency falling function	1100H	●	0xE2E
F14.47	Fast frequency falling threshold	3.0% ~ 15.0%	5.0%	●	0xE2F
F14.48	Constant torque frequency limit coefficient	80.0% ~ 150.0%	100.0 %	●	0xE30
F14.49	Sudden voltage increase threshold	0.0% ~ 20.0%	5.0%	●	0xE31

F14.50	Reserved				0xE32
F14.51	Reserved				0xE33
F14.52	Reserved				0xE34
F14.53	Intermittent operation & alarm selection	<b>LED"0" digit:</b> Intermittent operation storage selection 0.Invalid 1.Valid <b>LED"00" digit:</b> Stop mode while alarm 0.DEC stop 1.Free stop <b>LED"000" digit:</b> Reserved <b>LED"0000" digit:</b> Reserved	0000H	○	0xE35
F14.54	Repeat times of intermittent operation	0 ~ 1000	0	●	0xE36
F14.55	Start time of intermittent operation	0min ~ 3000min	0	●	0xE37
F14.56	Stop time of intermittent operation	0min ~ 3000min	0	●	0xE38
F14.57	Setting frequency of pump cleaning	0.00Hz ~ 300.00Hz	25.00Hz	●	0xE39
F14.58	FWD running time	0s ~ 3000s	30s	●	0xE3A
F14.59	REV running time	0s ~ 3000s	30s	●	0xE3B
F14.60	Repeat times of pump cleaning	0 ~ 60	5	●	0xE3C
F14.61	Power upper limitation	0.0 ~ 1000.0	0.0	●	0xE3D
F14.62	Kp of power limitation	0.0 ~ 100.0	1.0	●	0xE3E
F14.63	Ki of power limitation	0.0 ~ 100.0	1.0	●	0xE3F

## Terminal of Input and Output Function Selection

X	Function Specification	X	Function Specification	X	Function
0	No function	20	PID control cancel	43	Counter clear
1	FWD	21	PID control pause	44	DC braking
2	REV	22	PID trait switch	45	Pre excitation
3	3-line running(Xi)	23	PID gain switch	48	Command channel switch to keyboard
4	FWD JOG	24-26	PID given switch 1-3	49	Command channel switch to terminal
5	REV JOG	27-29	PID feedback switch1-3	50	Command channel switch to
6	Free stop	30	PLC pause	51	Command channel switch to expansion
7	Emergency stop	31	PLC restart	52	Operation banned
8	Malfunction reset	32	ACC/DEC time selection	53	Forward banned



9	External malfunction input	33	ACC/DEC time selection	54	Reverse banned
10	Frequency UP	34	ACC/DEC pause	60	Speed torque control
11	Frequency DW	35	Swing frequency input	61	Position control
12	UP/DW clear	36	Swing frequency	61-79	Reserve
13	Switch channel A to channel B	37	Swing frequency reset	80	Water-full detect alarm
14	Channel combination switch to	40	Timer trigger terminal	81	Water-full detect alarm recovery
15	Channel combination switch to	41	Timer clear terminal	82	Hybrid mode
16-19	Multispeed terminal 1-4	42	Counter input	83	Dry running input
<b>Y</b>	<b>Function Specification</b>	<b>Y</b>	<b>Function Specification</b>	<b>Y</b>	<b>Function</b>
0	No output	1	FWD running	2	REV running
3	FWD running	4	Fault warning 1,enable output including fault reset auto period	5	Fault trip alarm 2(no alarm when fault self-recovery)
6	External fault stop	7	External fault stop Under voltage	8	Finish ready for running
9	Output frequency level detection 1(FDT1)	10	Output frequency level detection 2(FDT2)	11	Reach given frequency
12	0 speed running	13	Reach upper limit	14	Reach lower
15	Program running circle completed	16	Program running segment completed	17	PID feedback exceeds upper limit
18	PID feedback under lower limit	19	PID feedback sensor wires	21	Timer time arrived
22	Counter reaching max value	23	Counter reach set value	24	Braking
25	PG feedback wire break	26	Emergency stop	27	Load pre-alarm
28	Load pre-alarm output 2	29	Solar alarm output prompt	30	RS485 given

### Monitor Code

Access 'C' parameter group by pressing 'PRG' for more than 2s; check the current state of VFD

#### 1. C00-Basic Parameter Monitor Group:

Function code	Function name	Unit and definition	Addresses	Function Code	Function name	Unit and definition	Addresses
C00.00	Given frequency	0.01Hz	0x2100	C00.20	Analog output AO1	0.01V/0.01mA/0.01kHz	0x2114

C00.01	Output frequency	0.01Hz	0x2101	C00.21	Analog output AO2(extended)	0.01V/0.01mA/0.01kHz	0x2115
C00.02	Output current	0.1A	0x2102	C00.22	Counting value of counter		0x2116
C00.03	Input voltage	0.1V	0x2103	C00.23	Running time after power on	0.1 hour	0x2117
C00.04	Output voltage	0.1V	0x2104	C00.24	Accumulative running time of this VFD	hour	0x2118
C00.05	Machine speed	1RPM	0x2105	C00.25	VFD power level	kW	0x2119
C00.06	Given torque	0.1%	0x2106	C00.26	VFD rated voltage	V	0x211A
C00.07	Output torque	0.1%	0x2107	C00.27	VFD rated current	A	0x211B
C00.08	PID given value	0.1%	0x2108	C00.28	Software version		0x211C
C00.09	PID feedback value	0.1%	0x2109	C00.29	PG feedback frequency	0.01Hz	0x211D
C00.10	Output power	0.1%	0x210A	C00.30	Counted time of timer	sec/min/hour	0x211E
C00.11	Bus voltage	0.1V	0x210B	C00.31	PID output value	0.00%	0x211F
C00.12	Module temperature 1	0.1°C	0x210C	C00.32	Software sub-version		0x2120
C00.13	Module temperature 2	0.1°C	0x210D	C00.33	Encoder angle	0.1°	0x2121
C00.14	Input terminal X on state	See input terminal diagram	0x210E	C00.34	Encoder deviation accumulative	1	0x2122
C00.15	Output terminal Y on state	See output terminal diagram	0x210F	C00.35	Encoder Z signal pulse count	1	0x2123
C00.16	Analog AI1 input value	0.001V/0.001mA	0x2110	C00.36	Fault pre alarm code	1	0x2124
C00.17	Analog AI2 input value	0.001V/0.001mA	0x2111	C00.37	Total power consumption (low bit)	1°	0x2125

C00.18	Reserved		0x2112	C00.38	Total power consumption (high bit)	10000°	0x2126
C00.19	Pulse input value of PUL port	0.001kHz	0x2113	C00.39	Power factor angle	1°	0x2127

## 2、C01-Malfunction Diagnosis Monitor Group

Function	Function	Unit and definition	Address
C01.00	Malfunction types	See fault code table	0x2200
C01.01	Malfunction diagnosis information	See fault code table	0x2201
C01.02	Malfunction running frequency	0.00~Max frequency	0x2202
C01.03	Malfunction output Voltage	0V~1500V	0x2203
C01.04	Malfunction out Current	0.1A~1000.0A	0x2204
C01.05	Malfunction Bus Voltage	0V~3000V	0x2205
C01.06	Malfunction module temperature	0°C~100°C	0x2206
C01.07	Malfunction machine state	LED "0" digit: Running direction	0x2207
C01.08	Malfunction input terminal status	See input terminal chart	0x2208
C01.09	Malfunction output terminal status	See output terminal chart	0x2209
C01.10	The last malfunction types	Please see malfunction code table	0x220A
C01.11	The first diagnosis information	Please see malfunction code table	0x220B
C01.12	The last malfunction running frequency	0.00~Maxfrequency	0x220C
C01.13	The last malfunction output voltage	0V~1500V	0x220D
C01.14	The last malfunction output current	0.1A~2000.0A	0x220E
C01.15	The last malfunction bus voltage	0V~3000V	0x220F
C01.16	The last malfunction module temperature	0°C~100°C	0x2210
C01.17	The last malfunction machine state	LED "0" digit: Running direction	0x2211
C01.18	The last malfunction input terminal state	See input terminal chart	0x2212
C01.19	The last malfunction output terminal state	See output terminal chart	0x2213
C01.20	The first two malfunction types	Please see malfunction information code table	0x2214
C01.21	The first two diagnosis information		0x2215
C01.22	The first three malfunction types		0x2216
C01.23	The first three diagnosis information		0x2217

## 3、Photovoltaic Pump Special Monitor Parameters

Function code	Function name	Setting range and definition	Default setting	property	Comm Add
C02.00	Frequency reference	0.01Hz	Read only		2300H
C02.01	Output frequency	0.01Hz	Read only		2301H
C02.02	Output current	0.1A	Read only		2302H
C00.04	Output voltage	0.1V	Read only		2104H
C02.10	Output power	0.01kW	Read only		230AH

C02.11	DC bus voltage	0.1V	Read only		230BH
C02.12	Module temperature 1	0.1°C	Read only		230CH
C02.30	DC current	0.01A	Read only		231EH
C02.31	Flow speed	0.1m <sup>3</sup> /h	Read only		231FH
C02.32	Voc voltage	0.1V	Read only		2320H
C02.33	Flow per day	0.1m <sup>3</sup>	Read only		2321H
C02.34	Cumulative total flow(low position)	0.1m <sup>3</sup>	Read only		2322H
C02.35	Cumulative total flow(high position)	0.1km <sup>3</sup>	Read only		2323H
C02.36	Generated power per day	0.01kWh	Read only		2324H
C02.37	Cumulative total generated power (low position)	0.01kWh	Read only		2325H
C02.38	Cumulative total generated power (high position)	0.1mWh	Read only		2326H

## Chapter 6 Function Parameter Specifications

### 6.1 F0: Basic Parameters

F00.00	Motor control mode	Setting range: 0~8	Default: 0
--------	--------------------	--------------------	------------

#### Asynchronous Motor Control Mode (AM) :

##### 0: V/F control

When the frequency (F) is adjustable, the ratio of the control frequency to the voltage (V) is kept constant. The control mode is used for speed control without requiring fast response and high precision.

##### 3: High-performance VC without PG

There is without speed sensor vector control, which is used for speed control that requires high precision. Under this mode control, the torque can respond fastly even without using the speed feedback signal of the motor, and a large torque can be obtained when the low speed motor is running. For better control, please make motor parameter auto-tuning.

##### 4: High-performance VC with PG

There is vector control with speed sensor, which is used for speed control of fast torque response and high performance torque control.

Mainly used for high-precision speed control, torque control, simple servo control and other places where strict control performance is required. For better control, please make motor parameter auto-tuning. In order to receive the speed feedback signal of the motor, you need to use the PG option card.

In order to receive the speed feedback signal of the motor, you need to use the PG optional card.

#### Synchronous Motor Control Mode (PM) :

##### 6: High-performance VC without PG

The permanent magnet synchronous motor has no PG feedback vector control. Through the software algorithm, the complete model and observer of the permanent magnet synchronous motor are built in, and the magnetic pole position and speed of the motor are observed in real time.

The mode requires complete no-load identification of the motor, which is suitable for occasions where the acceleration/deceleration time is high and the load is an impact load.

##### 7: High-performance VC with PG

The permanent magnet synchronous motor has speed sensor control, featuring dynamic response and high control performance. It can perform torque control and weak magnetic high-speed operation, and can be used for high-power servo control.

##### 1, 2, 5: Reserved

**Notes:**

- **PG** refers to the speed encoder, used as **PG** vector control, generally with photoelectric encoder or rotary transformer, need to select the corresponding **PG** card according to **PG** type and parameters, see function code [F05.30];
- When selecting the vector control mode, before the first run, first input the motor parameters correctly and perform automatic motor parameter tuning to obtain the correct motor parameters. For details, please refer to the detailed description of the "F05" motor parameter group.
- The parameters of the vector control parameter group should be correctly set to ensure good steady state and dynamic control performance. For the parameter setting and adjustment of the vector control parameter group, please refer to the detailed description of the "F06" parameter group.
- When selecting the vector control mode, it should be noted that the inverter can only drive one motor at the same time; and the inverter capacity and the motor capacity level cannot be too different, the inverter can be two or smaller than the motor power level. Failure to do so may result in reduced control performance or the drive system may not function properly.

F00.01	Reserved		
F00.02	Run command channel	Setting range: 0~3	Default: 0

Uses for selecting inverter running, stop and running direction command input channel.

**0: Keypad Control**

Running and stop of inverter control by forward running key **PRG** , stop key **STOP/RESET** of operator keypad. When [F04.07] parameter set to 1, REV/JOG is defined for JOG running.

**1: Terminal Control**

Running, stop and rotation direction of inverter control by terminal . See [F02.00~F02.09] for details. See [F02.23] for the terminal operation control mode and [F02.24] for the terminal startup protection.

**2: RS485 Communications Port Control**

The running command is given by the host computer through communication. For communication parameter settings, please refer to the F13 communication control parameter group.

When the peer-to-peer broadcast communication, the slave selects the run command transmitted by the host as the run command, please refer to [F13.09] for instructions.

When Modbus RS485 communication is valid, the running command is set and modified by address 0x3001/0x2001.

When the Profibus-DP communication is valid, the running command is set and modified by the corresponding address, see the Profibus-DP card instruction manual of the optional card.

**3: Option Card**

The operation and stop of the inverter are controlled by the external optional card communication. For the installation method and parameter setting of the optional card, please refer to the instruction manual of the same box with the optional card.

**Note:**

- **STOP/RESET of keypad, reset command from control terminal or RS485 communication are all enabled when fault reset.**

**Tips:**

- **The function of the STOP/RESET button of the keyboard can be selected. When external terminal control or communication control, it can be defined as the function of stop button, please refer to parameter [F04.08]; when using external terminal for running control, if using STOP of keyboard When the /RESET key is stopped, the inverter will stop and block the external terminal running command. At this time, the external terminal stop command must be input to unlock, and the external terminal running command is valid again. The communication control is the same.**

F00.03	Frequency given source channel A	Setting range: 0~11	Default: 0
F00.04	Frequency given source channel B	Setting range: 0~11	Default: 2

Select the given source of the inverter set frequency in [F00.03], [F00.04]; [F00.06] sets the relationship between channel A and channel B.

**0: Keyboard Number Given**

The set frequency is given by the parameter [F00.08] keyboard digital setting frequency; the current setting value of the parameter [F00.08] can be quickly modified by selecting the [F04.09] LED single digit selection keyboard up/down keys; Value power-down storage and up/down key action limit selection can be found in parameter [F04.09].

**1: Reserved****2: Voltage/Current Analog AI1 Given****3: Voltage/Current Analog AI2 Given**

The set frequency is given and modified by the input analog quantity AI1, AI2. By linearizing the input analog quantity value, the calibration 100% corresponds to the maximum frequency. For details, see "F03" parameter group analog quantity processing.

**4: Reserved****5: Terminal Pulse PUL Given**

The set frequency is given and modified by the control terminal (PUL) input pulse signal; by linearizing the input pulse signal, the calibration is 100% corresponding to the maximum frequency, see parameter [F02.27~F02.33] for details.

**6: RS485 Communication Given**

The set frequency is given by the communication method. For the communication parameter setting, please refer to the F13 communication control parameter group.

When the peer-to-peer broadcast communication, the slave selects the host to transmit the given frequency or output frequency as the set frequency, please refer to [F13.09] for instructions. When Modbus RS485 communication is valid, the set frequency can be set and modified by address 0x3000/0x2000. See Appendix 2: Modbus Communication Protocol.

When the Profibus-DP communication is valid, the set frequency is set and modified by the corresponding address. See the Profibus-DP card instruction manual of the optional card.

When the CAN-RS485 communication is valid, the set frequency is set and modified by the corresponding address. See the instruction manual of the optional CAN-RS485 card.

**7: Terminal UP/DW Control**

The set frequency is controlled by the control terminal to increase and decrease, and the "frequency

increment (UP)" terminal and the "frequency decrement (DW)" terminal and (COM) of the multi-function terminal (X1 to X10) are controlled to be turned on and off. For details, see the parameter description of the [F02.00~F02.09] terminal.

### 8: PID Control Given

When [F00.03] or [F00.04] selects the channel, the inverter running mode is process PID control, the set frequency is the output after PID action, the PID control gives the quantitative and feedback quantity and other control parameters. The process PID controls the parameter group "F11".

The current set value of the parameter [F11.01] can be quickly modified by selecting the [F04.09] LED single digit up/down key. The parameter value power-down storage and up/down key action limit selection are detailed in the parameter [F04.09].

The status and characteristics of the PID control can be changed through the multi-function input terminal. For details, see the parameter description of the [F02.00~F02.09] terminal.

### 9: Program Control (PLC) Given

The set frequency and the running direction of the inverter are controlled by the process of the simple PLC inside the inverter, and the process can control up to 15 speeds. For details, see parameter "F12" multi-speed, PLC function and swing frequency parameter group;

If a speed running time is set to "0", the program speed is skipped when the program is running, which makes it easy to set the speed of the program running. When the parameter [F00.16] LED hundred bit is set to "0", the frequency control direction is invalid or [F00.16] LED tens place is set to "1", when reverse rotation is prohibited, if any speed running command direction setting In order to reverse, the inverter runs at a frequency of 0.00 Hz at this speed.

Both the program operation and the multi-speed operation are to realize the variable speed operation of the inverter according to a certain rule. In multi-speed operation, multi-speed switching and running direction change are realized by different combinations of "multi-speed control terminals 1-4" and (COM) defined in "multi-function input terminal". The program running function can not only define the multi-segment frequency of one cycle in the function parameters, but also the time, direction, acceleration/deceleration time and cycle mode of multi-segment frequency operation can also be defined in the function parameters. The multi-speed control terminal can be defined by any multi-function terminal. For details, refer to the parameter description of the [F02.00~F02.09] terminal.

### 10: Optional Card

The setting frequency is given and modified by the external optional card communication. For the installation method and parameter setting of the optional card, please refer to the instruction manual of the same box with the optional card.

### 11: Multi-steps Speed Given

The set frequency is selected by the "multi-speed terminal". If the frequency channels A and B are not selected for the multi-speed reference, the multi-speed terminal has a higher priority to switch the frequency to the multi-speed reference; if A, B, When a multi-speed speed reference is selected for one channel, the combination of frequency source settings is performed. When the multi-speed terminal is invalid, the multi-speed speed is given as zero. For the "multi-speed terminal", please refer to the parameter description of the [F02.00~F02.09] terminal.

F00.05	Frequency channel B reference source	Setting range: 0~1	Default: 0
--------	--------------------------------------	--------------------	------------



The reference source of the frequency reference channel B is selected by this parameter, and the reference source of the frequency reference channel A is the maximum frequency [F00.09].

#### 0: Reference Source with Maximum Frequency

##### 1: Use Channel A to set the Frequency as the Reference Source

Channel B setting frequency = Channel B frequency reference source × Channel A setting frequency absolute value / Maximum frequency

F00.06	Frequency given source selection	Setting range: 0~5	Default: 0
--------	----------------------------------	--------------------	------------

Uses for selecting frequency given A channel and B channel combination.

**0: Channel A** is valid only for channel A[F00.03], and channel B[F00.04] is invalid.

**1: Channel B** is valid only for channel B[F00.04], and channel A[F00.03] is invalid.

**2: Channel A+Channel B** Channel A [F00.03] sets the frequency plus channel B[F00.04] setting frequency, and the sum of the two is the frequency set by the inverter.

**3: Channel A-Channel B** Channel A[F00.03] sets the frequency minus the channel B[F00.04] setting frequency. The difference between the two is the frequency set by the inverter. This method may generate a negative frequency. Whether the output is valid when a negative frequency is generated is determined by the [F00.16] setting.

**4: Maximum Value of Channel A and Channel B** Channel A [F00.03] set frequency and channel B [F00.04] set frequency to take the maximum value, the larger is the inverter set frequency.

**5: Minimum Value of Channel A and Channel B** Channel A [F00.03] set frequency and channel B [F00.04] set frequency to take the minimum value, the smaller is the inverter set frequency.

#### Notes:

- When the jog run command is valid, the jog set frequency is used as the inverter set frequency.
- No multi-speed speed is selected for channels A and B. If multi-speed terminal selection is valid, the corresponding frequency is selected as the inverter setting frequency.
- When the given sources selected by channels A and B are the same, no superposition calculation is performed, and the given source frequency of channel A is used as the set frequency of the inverter.
- Frequency given source priority: From high to low, it is jog running frequency setting, multi-speed speed setting, running command bundling given frequency, frequency given source channel.
- If the rotation direction selection [F00.16] is set to reverse prohibition, the inverter will output a frequency of 0.00Hz regardless of the value of the frequency control direction selection and the frequency calculation result is negative.

#### Tips:

- The given frequency after the combination of frequency reference channel A and frequency reference channel B is still limited by the upper limit frequency and lower limit frequency.

F00.07	Running Command Binding	Setting range: 0000~DDDD	Default: 0000
--------	-------------------------	--------------------------	---------------

When this parameter is valid, it is used to set the channel source frequency channel for each running command channel. When the command source has a bundled frequency source, the set frequency is given by the frequency source bundled by [F00.07], and the set frequency obtained by [F00.03~F00.06] will no longer

be used. Effective, but [F00.16] LED hundred-bit frequency direction control is still valid.

**LED “0” digit: keyboard command bundle**

- 0: No binding Press the [F00.03~F00.06] setting to determine the frequency reference.
- 1: keyboard digital given frequency
- 2: Reserved
- 3: Voltage / current analog AI1 given
- 4: Voltage/current analog AI2 given
- 5 reservations
- 6: Terminal pulse PUL given
- 7: RS485 communication given
- 8: Terminal UP/DW control
- 9: PID control given
- A: Program control PLC given
- B: Option card
- C: multi-speed speed given
- D: Reserved

The above 1~12 items are the same as the frequency given channel A selection [F00.03].

**LED “00” digit: terminal command bundle**

The setting range of 1~12 is the same as the LED ones: the keyboard command instruction bundle description is consistent

**LED “000” digit: Communication command bundle**

The setting range of 1~12 is the same as the LED ones: the keyboard command instruction bundle description is consistent.

**LED “0000” digit: Optional card command bundle**

The setting range of 1~12 is the same as the LED ones: the keyboard command instruction bundle description is consistent.

**Examples:** If remote/in-place switching is used, the remote mode uses the communication command reference and frequency reference. The local mode uses the terminal command reference and the keyboard digital frequency reference.

The setting parameters are as follows: [F00.02=2: Communication Control] [F00.03=6: Communication Reference] [F00.07=0010: Ten-digit terminal command command bundled keyboard digital reference frequency] [F02.04=49 : Command channel is switched to terminal].

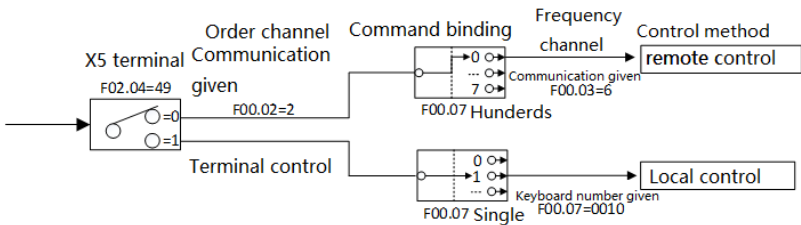

F00.08	Keyboard digital setting frequency	Set range: 0.00 ~ Upper limit frequency	Default: 50.00Hz
--------	------------------------------------	---	------------------

This parameter is valid when the frequency reference channel [F00.03, F00.04] is set to “0: Keyboard Digital Reference” and is used to set and modify the keyboard digital setting frequency.

F00.09	Max frequency output	Setting range: Upper limit frequency ~ 600.00Hz	Default: 50.00Hz
F00.10	Upper limit frequency source selection	Setting range: 0~7	Default: 0
F00.11	Upper frequency limit digital setting	Setting range: Lower limit frequency ~ Max frequency	Default: 50.00Hz
F00.12	Lower limit frequency	Setting range: 0.00 ~ Upper limit frequency	Default: 0.00Hz
F00.13	Lower limit frequency running mode	Setting range: 0 ~ 1	Default: 1

#### Maximum frequency:

When the analog input, pulse input (PUL), multi-speed, etc. in the inverter are used as the frequency source, 100% of each is the relative maximum frequency calibration; when the [F01.16] LED bits are set to “0”, the maximum The frequency is used as the reference frequency for the acceleration/deceleration time.

#### Upper frequency source selection:

Select a given source for the upper limit frequency of the drive. The upper limit frequency is the upper limit of the given frequency and limits the given frequency.

0: Upper limit frequency digital reference Set by parameter [F00.11].

1: reserved

2: voltage / current analog AI1 given

3: voltage / current analog AI2 given

4: Reserved

5: terminal pulse PUL given

6: RS485 communication setting Set by address 0x3004/0x2004, please refer to Appendix 2: Modbus Communication Protocol

7: Option card

When using keyboard potential, analog (AI1, AI2), terminal pulse (PUL), RS485 communication reference, and optional card, similar to frequency reference channel A, please refer to [F00.03].

#### Upper limit frequency digital setting:

The upper limit frequency is given to the channel when [F00.10] is set to "0".

#### Lower limit frequency:

The lower limit frequency is the lower limit of the given frequency and limits the given frequency.

When the set frequency is lower than the lower limit frequency, the inverter sets the lower limit frequency

operation mode by [F00.13].

#### Lower limit frequency operation mode:

0: Stop output, enter the pause operation state, maintain the running state, no voltage output.

1: Lower limit frequency operation When the actual set frequency is lower than the lower limit frequency, the inverter runs at the limit frequency.

**Note: The maximum frequency, upper limit frequency and lower limit frequency should be set carefully according to the requirements of the operating conditions. In addition to the upper limit frequency and lower limit frequency, the output frequency of the inverter during operation is also limited by the set values of the start frequency, stop detection frequency, stop DC brake start frequency, and skip frequency. The relationship between the maximum frequency, upper limit frequency and lower limit frequency is shown in the figure below.**

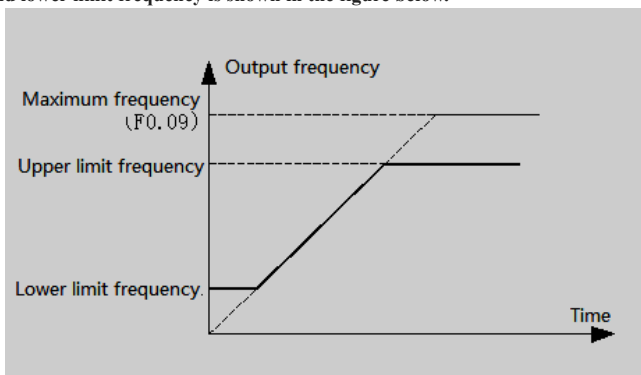

Schematic diagram of upper and lower frequency and maximum frequency

F00.14	ACC time 1	Setting range: 0.00~650.00s	Default: Model setting
F00.15	DEC time 1	Setting range: 0.00~650.00s	Default: Model setting

The acceleration time refers to the time required for the output frequency to accelerate from 0.00 Hz to the time reference frequency, and the deceleration time refers to the time required for the output frequency to decelerate from the time reference frequency to 0.00 Hz. The maximum frequency, fixed frequency 50Hz, and given frequency can be selected as the time reference frequency by parameter [F01.16] LED bits. The acceleration/deceleration curve is selected by [F01.16] LED ten-digit line and S-curve acceleration/deceleration. See parameter [F01.16] for details.

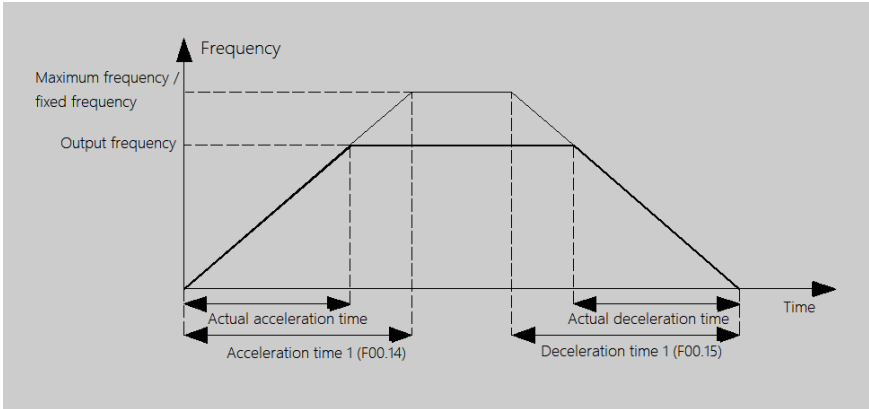

Four groups of acceleration and deceleration time can be selected for normal frequency acceleration and deceleration. Acceleration / deceleration time 1 is set by [F00.14~F00.15], acceleration/deceleration time 2, acceleration / deceleration time 3, and acceleration/deceleration time 4 are set by [F01.21~F01.26]. Acceleration/deceleration time 1 is the default acceleration / deceleration time group. If you want to select other acceleration / deceleration time group, you can select it through the control terminal. For details, see parameter [F02.00~F02.09].

When the program is running, each of the program running segments can select one of the four groups of acceleration and deceleration time, regardless of the terminal selection. See [F12.31~F12.45] for details.

The jog acceleration and deceleration time are set by [F01.39, F01.40].

The emergency stop deceleration time is set by [F01.27].

F00.16	Rotary direction selection	Setting range: 0000~0121	Default: 0000
--------	----------------------------	--------------------------	---------------

**LED “0” digit: reverse the running direction**

Used to select the adjustment of the motor running control direction.

0: The direction is unchanged The actual steering of the motor is the same as the required steering, and the current motor direction is not adjusted;

1: Inverted direction The actual steering of the motor is opposite to the required steering, and the current motor direction is adjusted;

**LED “00” digit: no direction of operation**

Used to select the effectiveness of the motor's running control direction.

0: Allow forward and reverse commands The inverter accepts forward and reverse commands to control motor operation;

1: Only forward command is allowed. The inverter only accepts the forward rotation control command to control the motor operation. If the inverter is given the reverse command, the inverter will not run.

2: Only reverse command is allowed. The inverter only accepts the reverse control command to control the motor operation; if the forward rotation command is given, the inverter will not run.

**LED “000” digit: frequency control direction selection**

It is used to select whether the negative frequency is allowed to change the current running direction of the

inverter when the frequency reference value is negative.

0: Invalid frequency control direction If the calculation result is negative, the inverter outputs a frequency of 0.00Hz.

1: Frequency control direction is valid If the calculation result is negative, the inverter changes the current running direction and outputs the corresponding frequency.

**Tips: The set value of this parameter will not be changed when the factory value is restored. When this parameter is set to a value, all commands that run the command channel (operating keyboard, external terminal, RS485 communication, optional card, and program operation) are affected by the selected value.**

F00.17	G/P Model Setting	Setting range: 0~1	Default: 0
--------	-------------------	--------------------	------------

The set value of this parameter will not be changed when the factory value is restored.

**0: Model G** is suitable for constant torque loads.

**1: Model P** type machine Suitable for variable torque load (fan, pump type load).

The AC300 series inverter adopts the G/P combination method for constant torque load (G type) to adapt the motor power ratio to the fan water. The pump type load (P type) is a small one.

F00.18	Reserved
--------	----------

F00.19	Parameter initialization	Setting range: 0~3	Default: 0
--------	--------------------------	--------------------	------------

**0: no operation**

**1: Restore factory value (do not restore motor parameter F05.00-F05.19)** After the parameters are restored to the factory default values, the function parameters are restored to the default values before leaving the factory, excluding the motor parameter group.

**2: Restore factory defaults (including motor parameters F05.00-F05.19)** After the parameters are restored to factory defaults, the function parameters are restored to the factory default values and restored together with the motor parameter group.

**3: Clear fault record** Clear all historical fault information recorded in [C01.00~C01.23].

**Tips:**

- The factory default setting [F00.19=1 or 2] is restored, and the current setting values of the parameters [F00.16-F00.17] and [F04.14~F04.21] are not changed.
- When the factory default value is restored, the keyboard will display “SAVE”. After the “SAVE” jumps to the parameter interface, the parameter initialization is completed. If the power is suddenly turned off during the display of “SAVE”, the inverter only performs some parameters to restore the factory values. Please power on again to restore the factory values.

## 6.2 F1: Operation Control Parameters Group

F01.00	Start-up running mode	Setting range: 0~2	Default: 0
F01.01	Start pre-excitation time	Setting range: 0.00~60.00s	Default: Model setting
F01.02	Start-up frequency	Setting range: 0.00~60.00Hz	Default: 0.50Hz
F01.03	Start-up frequency holding time	Setting range: 0.0~50.0s	Default: 0.0s
F01.04	Braking current before start	Setting range: 0.0~150.0%	Default: 60.0%
F01.05	Braking time before start	Setting range: 0.0~60.0s	Default: 1.0s

### Start Mode:

0: Start the inverter by the starting frequency and control the inverter to start with the starting frequency set by [F01.02] and the starting frequency duration set by [F01.03]. It is suitable for occasions where the static friction torque is large and the load inertia is small or when the user cooperates with an external mechanical brake device. (After the motor stops, it will start again. If the motor is in the rotating state before starting, it may cause overcurrent fault.)

1: First DC braking and then starting from the starting frequency Firstly, the pre-starting braking current [F01.04] and the pre-starting braking time [F01.05] apply a certain amount of DC braking energy to the load motor (ie electromagnetic brake), and then start from the starting frequency; suitable for small inertia loads with forward or reverse rotation in the stop state.

2: Start after the speed tracking and direction judgment. The inverter first detects the speed and direction of the motor, and then starts to increase to the given frequency according to the acceleration/deceleration time at the detected speed.

### Start Pre-excitation Time:

This parameter is used to set the time for pre-excitation of the asynchronous motor at startup. This parameter can establish a magnetic field before the motor starts, which can effectively improve the starting performance of the motor and reduce the starting current and starting time.

### Start Frequency:

It is the initial output frequency when the inverter starts. Setting a suitable starting frequency can have a higher starting torque. For some loads with a large static friction at rest, some momentum can be obtained at the moment of starting. However, if the set value is too large, problems such as E.oC1 may occur.

### Start Frequency Duration:

It refers to the time when the inverter maintains the starting frequency and starts to enter normal acceleration and deceleration after the time is maintained.

### Braking Current Before Starting:

It refers to the amount of braking current that the inverter sends into the motor during DC braking. 100.0% corresponds to the rated current of the motor. The DC braking function at start-up is only available when [F01.00] is set to "1". Setting this parameter to 0 starts DC braking execution is invalid.

**Braking Time Before Starting:**

It refers to the duration of DC braking current at startup; only when [F01.00] is selected as "1", there will be DC braking function at startup; when braking time is 0.0 seconds, there is no DC braking process.

**Note:**

- The starting frequency is not limited by the lower limit frequency [F00.12] and the zero speed torque frequency threshold [F01.29].**

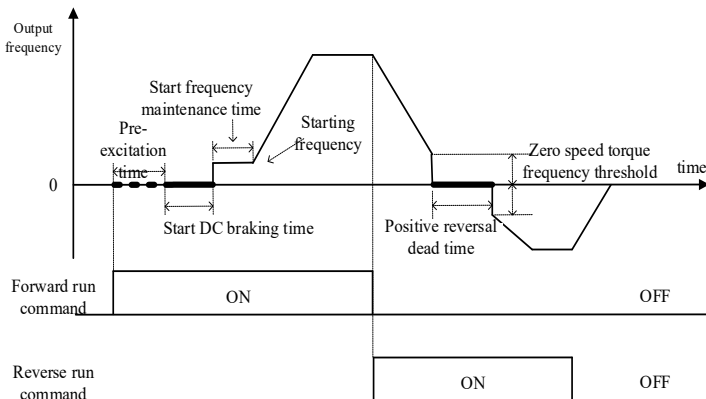

Startup and forward and reverse switching process diagram

F01.06	Speed tracking time	Setting range: 0.00~60.00s	Default: 0.50s
F01.07	Speed tracking delay when stop	Setting range: 0.00~60.00s	Default: 1.00s

**Speed Tracking Speed:**

It refers to the time taken by the output voltage to increase to the normal voltage at the current speed during the start of the inverter speed tracking. The shorter the time, the faster the tracking process, but the greater the current impact generated by the tracking process. The internal speed of the inverter is automatically controlled.

**Speed Tracking Stop Delay:**

It means that after the inverter cuts off the output, it takes a certain delay to re-output the voltage to start the motor, so that the inrush current at startup is as small as possible. When the time is zero, the delay is automatically controlled by the inverter.

F01.08- F01.09	Reserved
----------------	----------

F01.10	Stop mode	Setting range: 0~1	Default: 0
--------	-----------	--------------------	------------



**0: Deceleration stop**

According to the set deceleration time and deceleration mode, the inverter stops output after decelerating to the frequency of 0.00Hz.

During the deceleration stop, when the output frequency is less than the stop DC braking start frequency [F01.11], the output frequency of the inverter will jump to zero, DC braking will be performed and the operation will be stopped after execution; otherwise the inverter will decelerate to Stop working after the minimum output frequency.

**1: Free stop**

The inverter blocks the output immediately after receiving the stop command, and the motor runs freely until it stops. When this mode is selected, it is generally combined with an external mechanical brake to achieve rapid stop.

F01.11	DC braking initial frequency when stop	Setting range: 0.00~50.00Hz	Default: 1.00Hz
F01.12	DC braking current when stop	Setting range: 0.0~150.0%	Default: 60.0%
F01.13	Reserved		
F01.14	DC braking hold time when stop	Setting range: 0.0~60.0s	Default: 0.0s

**Stop DC braking start frequency:**

It means that when the inverter decelerates to this frequency, it will stop output and start DC braking function; when it stops, when the output frequency is lower than the stop DC braking start frequency, the DC braking function will be activated.

During the deceleration stop, when the given frequency is less than the stop DC braking start frequency, DC braking is started and the output frequency of the inverter jumps to zero. If the operating conditions do not have strict requirements for the stop brake, the DC brake start frequency should be set as small as possible during the stop.

**DC braking current at stop:**

It refers to the amount of braking current that the inverter sends into the motor during DC braking. This value 100.0% corresponds to the rated motor current.

The DC braking function provides zero speed torque. It is usually used to improve the shutdown accuracy and achieve a quick stop, but it cannot be used for deceleration braking during normal operation; that is, once DC braking is started, the inverter will stop output. The DC braking current setting is too large, and an overcurrent fault is likely to occur when the inverter is stopped. If this parameter is set to 0, the stop DC brake execution is invalid.

**Stop DC braking duration:**

It refers to the time when the DC braking current lasts during the stop. When the braking time is 0.0 seconds, there is no DC braking process, that is, the DC braking function is invalid. If this parameter is set to 0, the stop DC brake execution is invalid.

F01.15	Stop detection frequency	Setting range: 0.00~50.00Hz	Default: 0.50Hz
--------	--------------------------	-----------------------------	-----------------

**Stop detection frequency:**

When the speed is reduced, the inverter will enter the stop state when the output frequency is less than this value.

F01.16	ACC/DEC selection	Setting range: 0000~0012	Default: 0010
F01.17	ACC start time for S curve	Setting range: 0.00~10.00s	Default: 0.20s
F01.18	ACC end time for S curve	Setting range: 0.00~10.00s	Default: 0.20s
F01.19	DEC start time for S curve	Setting range: 0.00~10.00s	Default: 0.20s
F01.20	DEC end time for S curve	Setting range: 0.00~10.00s	Default: 0.20s

**Acceleration and deceleration selection****LED “0” digit: acceleration/deceleration time reference frequency**

This parameter is used to select the basis for the acceleration/deceleration time.

**0: Maximum frequency** The reference for the acceleration/deceleration time is the maximum frequency [F00.09].

**1: Fixed frequency** The reference for the acceleration/deceleration time is 50.00 Hz fixed frequency.

**2: Setting frequency** The reference of acceleration/deceleration time is the set frequency. If the set frequency changes frequently, the acceleration of the motor will change, so pay attention to the application.

**LED “00” digit: acceleration and deceleration mode**

This series of inverters provides two kinds of acceleration and deceleration modes; two kinds of acceleration and deceleration modes are valid during normal start, stop, forward and reverse, acceleration and deceleration.

0: Straight line Generally suitable for general purpose loads.

1: S curve S-type acceleration and deceleration curves are mainly provided to reduce noise and vibration during acceleration and deceleration, reduce the start-stop impact or low-frequency need to reduce the torque, and the high-frequency needs short-time acceleration and other loads.

**LED “000” digit: Reserved****LED “0000” digit: Reserved**

The characteristics of the S curve during forward and reverse rotation are as follows:

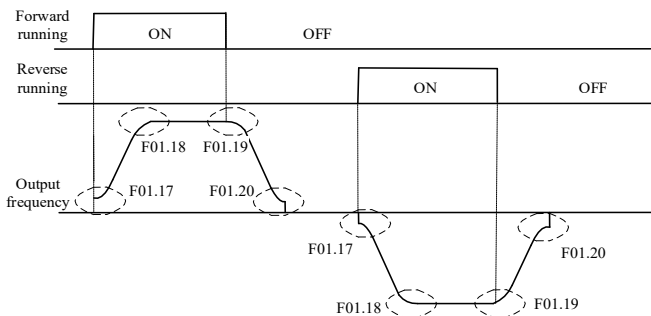

Schematic diagram of S curve

**Tips:**

- After setting the S curve, the acceleration/deceleration time will be extended as follows:  
 Acceleration time = selected acceleration time +  $([F01.17]+[F01.18])/2$   
 Deceleration time = selected deceleration time +  $([F01.19]+[F01.20])/2$
- The acceleration S curve is divided into three segments. Start S curve time [F1.17], acceleration time [F0.14], end S curve time [F1.18]. Total acceleration time = acceleration time [F0.14] +  $([F1.17]+[F1.18])/2$ , try to ensure the selected acceleration time  $[F0.14] \geq ([F1.17]+ [F1.18])/2$ . When  $[F0.14] < ([F1.17]+ [F1.18])/2$ , the total acceleration time will be calculated by the software itself and will deviate from the set time.
- The deceleration S curve is the same as the acceleration S curve.

F01.21	ACC time 2	Setting range: 0.01~650.00s	Default: 10.00s
F01.22	DEC time 2	Setting range: 0.01~650.00s	Default: 10.00s
F01.23	ACC time 3	Setting range: 0.01~650.00s	Default: 10.00s
F01.24	DEC time 3	Setting range: 0.01~650.00s	Default: 10.00s
F01.25	ACC time 4	Setting range: 0.01~650.00s	Default: 10.00s
F01.26	DEC time 4	Setting range: 0.01~650.00s	Default: 10.00s

**Acceleration time 2/3/4:**

When the parameter [F01.16] LED "0" digit is set to "0", it refers to the time required for the output frequency to accelerate from 0.00Hz to the maximum frequency;

When the parameter [F01.16] LED "0" digit is set to "1", it refers to the time required for the output frequency to accelerate from 0.00Hz to 50.00Hz;

When the parameter [F01.16] LED "0" digit is set to "2", it refers to the time required for the output frequency to accelerate from 0.00Hz to the set frequency;

See parameter [F01.16] for details.

**Deceleration time 2/3/4:**

When the parameter [F01.16] LED bit is set to "0", it refers to the time required for the output frequency

to decelerate from the maximum frequency to 0.00Hz;

When the parameter **[F01.16]** LED bit is set to "1", it refers to the time required for the output frequency to decelerate from 50.00 Hz to 0.00 Hz;

When the parameter **[F01.16]** LED bit is set to "2", it refers to the time required for the output frequency to decelerate from the set frequency to 0.00Hz;

See parameter **[F01.16]** for details.

Acceleration/deceleration time 2/3/4 can only switch the current acceleration/deceleration time group by the combination of the multi-function terminal "acceleration/deceleration time selection terminal 1" and "acceleration/deceleration time selection terminal 2" and **(COM)** (PLC program Except for operation); if the acceleration/deceleration time selection terminal is not set, the factory default value is that the acceleration/deceleration time 1 is valid, and the inverter performs acceleration/deceleration according to the acceleration/deceleration time 1.

The definition of the acceleration/deceleration time of the PLC program operation is detailed in the parameters **[F12.31~F12.45]**.

The jog acceleration/deceleration time is not within this range, and the jog acceleration and deceleration time are individually set by **[F01.39, F01.40]**.

Acceleration and deceleration time selection comparison table:

Terminal 2	Terminal 1	Acc/Dec time selection
OFF	OFF	Acc time 1/ Dec time 1
OFF	ON	Acc time 2/ Dec time 2
ON	OFF	Acc time 3/ Dec time 3
ON	ON	Acc time 4/ Dec time 4

If you have doubts about the above table, you can refer to the multi-speed multi-speed timing diagram of the "F12" parameter group.

F01.27	DEC time at emergency stop	Setting range: 0.01~650.00s	Default: 1.00s
--------	----------------------------	-----------------------------	----------------

It's used to set the deceleration time during emergency stop. The definition of emergency stop time is the same as the deceleration time. Please set the emergency stop time according to the site conditions to avoid over-current and over-current caused by abnormality. Over-voltage affects the deceleration time.

The emergency stop function can only be triggered by the input terminal (terminal function is set to "7: emergency stop"). For details, see parameter **[F02.00~F02.09] IO terminal, [F03.12, F03.15] AI2 terminal**.

When the multi-function output terminal is set to "26: Emergency stop", the output terminal always outputs a valid signal during the emergency stop.

See parameter **[F02.43~F02.50]** for details.

F01.28	FWD&REV dead time	Setting range: 0.0~120.0s	Default: 0.0s
--------	-------------------	---------------------------	---------------

**Positive and Negative Dead Time:**

This function is defined as the transition time that the inverter waits at 0.0Hz during the process from forward to reverse, or from reverse to forward rotation. The positive and negative dead time is mainly for large inertia load and there is machinery when changing steering. Set for the device in the dead zone.

F01.29	Zero speed torque frequency threshold	Setting range: 0.00~10.00Hz	Default: 0.50Hz
F01.30	Zero speed torque coefficient	Setting range: 0.0~150.0%	Default: 60.0%
F01.31	Zero speed torque holding time	Setting range: 0.0~6000.0s	Default: 0.0s

**Zero Speed Torque Function:**

It is effective under open loop V/F or open loop vector to set the output torque and duration of the inverter at zero speed.

Invalid in closed-loop control mode (the motor can achieve zero servo function under closed-loop control.)

**Zero Speed Torque Frequency Threshold:**

set the frequency threshold of the inverter to enter the zero speed state, as the judgment of the inverter entering the zero speed torque holding state one of the broken conditions.

**Zero Speed Torque Retention Factor:**

Set the output torque of the inverter when running at zero speed, 100% corresponds to the rated current of the motor.

**Zero Speed Torque Holding Time:**

Set the time to keep the motor output torque after the inverter enters the zero speed torque state.

[F01.31] When the set value is 0~5999.9s, the timer will start when the inverter enters the zero speed torque state (operating frequency is 0Hz). After the time reaches the set value, the inverter will stop zero speed torque hold and stop output. (Entering the stop state).

[F01.31] When the set value is 6000s, it will not be timed when the inverter enters the zero speed torque state (operating frequency is 0Hz). The zero speed torque state is valid for the long term by default, only after giving the stop command or given non-zero. The operating frequency only terminates the zero speed torque hold.

**The zero speed torque function enters the condition judgment:**

1. During the start-up speed of the inverter, when the given frequency is less than the starting frequency, the inverter output is zero, but does not enter the zero-speed torque function.

2. During the forward and reverse switching of the inverter during normal operation, when the output frequency is less than [F01.29], the output zero frequency, enter the zero speed torque function, when the zero speed torque holding time [F01.31] is greater than the positive and negative When the dead time [F01.28] is changed, the hold time is determined by the positive and negative dead time [F01.28].

3. When the inverter is in normal operation, change the frequency setting value during the speed-up and running process. When the speed is reduced, it will output zero frequency after [F01.29], enter the zero-speed torque function, and exit zero after zero speed torque holding time. Speed torque function.

4. During the inverter deceleration process, when the output frequency is less than the zero speed torque frequency threshold [F01.29], the zero speed torque function will not be entered, and the normal deceleration will be stopped. If the stop DC braking start frequency is greater than [F01.29], when the output frequency is less than the stop DC braking start frequency, the stop DC braking state is entered.

5. When the zero speed torque frequency threshold value exceeds the starting frequency [F01.02], the internal zero speed torque frequency threshold is limited to the starting frequency.

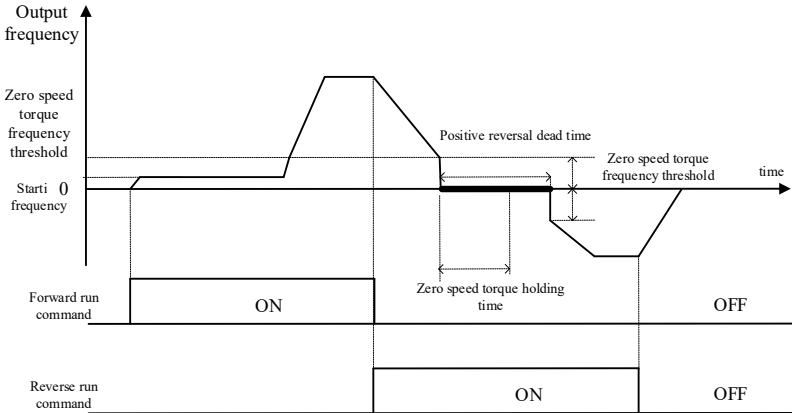

Zero speed torque frequency threshold

**Note:** If the zero speed holding torque is set too large or the zero speed holding torque time is set too long, pay attention to the temperature rise of the motor. If the motor temperature rises a lot, it is necessary to improve the heat dissipation of the motor plus the heat sink of the motor.

F01.32-F01.34	Reserved		
F01.35	Power off restart action selection	Setting range: 0~1	Default: 0
F01.36	Power off restart waiting time	Setting range: 0.00~60.00s	Default: 0.50s

**Power Failure Restart Action Selection:**

0: Invalid After the inverter is powered off and then powered on, it must be run after receiving the running command.

1: Valid If the inverter is in the running state before the power is cut off, after the power is restored, the inverter will start the automatic speed tracking after the waiting time set by [F01.36].

**Stop Restart Waiting Time:** This function is defined as the transition time that the inverter waits and restarts at 0.0 Hz.

The power failure restart wait time [F01.36] setting principle is based on factors such as the recovery recovery time of other equipment related to the inverter after power supply is restored.

During the waiting time of power failure restart, the inverter does not accept the running command, but if the stop command is input during this period, the inverter will cancel the restart state.

**Notes:**

- The power failure restart function can automatically start the inverter after power is restored. Therefore, it has great contingency, please use it carefully for the safety of people and equipment.
- Use the power failure restart function to ensure that the inverter runs valid signal before power off. When the keyboard operation control, RS485 communication control or optional card operation, if the inverter has power failure, the running command will be automatically cleared.
- When the running command uses the terminal two-wire control, if the running terminal has no input after power-on, the inverter will not run.

F01.37	Reserved		
F01.38	JOG running frequency setting	Setting range: 0.00 ~ Maximum frequency	Default: 5.00Hz
F01.39	JOG ACC time	Setting range: 0.01~650.00s	Default: 10.00s
F01.40	JOG DEC time	Setting range: 0.01~650.00s	Default: 10.00s

**Jog running frequency setting:** Set the output frequency of the inverter when jogging.

**Jog acceleration time:** The jog acceleration/deceleration time defines the same acceleration/deceleration time:

When the parameter [F01.16] LED "0" digit is set to "0", it refers to the time required for the output frequency to accelerate from 0.00Hz to the maximum frequency;

When the parameter [F01.16] LED "0" digit is set to "1", it refers to the time required for the output frequency to accelerate from 0.00Hz to 50.00Hz;

When the parameter [F01.16] LED "0" digit is set to "1", it refers to the time required for the output frequency to accelerate from 0.00Hz to the set frequency;

See parameter [F01.16] for details.

**Jog deceleration time:** Jog acceleration/deceleration time defines the same acceleration/deceleration time.

When the parameter [F01.16] LED "0" digit is set to "0", it refers to the time required for the output frequency to decelerate from the maximum frequency to 0.00Hz;

When the parameter [F01.16] LED "0" digit is set to "1", it refers to the time required for the output frequency to decelerate from 50.00 Hz to 0.00 Hz;

When the parameter [F01.16] LED "0" digit is set to "2", it refers to the time required for the output frequency to decelerate from the set frequency to 0.00Hz;

See parameter [F01.16] for details.

**Note:**

- The inverter can be controlled by the jog operation command of the keyboard, control terminal, communication command or optional card.
- Terminal jog has the highest priority command right. That is, in any state, once the terminal jog

command is valid, the jog acceleration/deceleration time is immediately run from the current running frequency to the jog frequency.

- Only the terminal jog run priority is not limited by the run command channel, and other jog commands have priority only when they are the same as the run command channel. For example, the keyboard jog operation is valid only when the keyboard control is running, and takes precedence over the keyboard forward/reverse run command.
- The set value of the jog running frequency is limited by the maximum frequency of [F00.09]. The actual output frequency during jog operation is limited by the upper limit frequency of [F00.11].

F01.41	Jump frequency 1	Setting range: 0.00~Maximum frequency	Default: 0.00Hz
F01.42	Jump frequency range 1	Setting range: 0.00~Maximum frequency	Default: 0.00Hz
F01.43	Jump frequency 2	Setting range: 0.00~Maximum frequency	Default: 0.00Hz
F01.44	Jump frequency range 2	Setting range: 0.00~Maximum frequency	Default: 0.00Hz

When the inverter is running with load, in order to avoid the output frequency of the inverter from the resonance frequency point of the mechanical load, the resonance frequency can be avoided by the jump frequency. The inverter can set two jumping points to perform the jump. After setting the skip frequency parameter, even if the set frequency of the inverter is within the resonant frequency point of the mechanical load, the output frequency of the inverter will be automatically adjusted to the outside of the resonant frequency of the mechanical load to avoid running at the resonance point, the skip frequency processing during acceleration and deceleration is as follows:

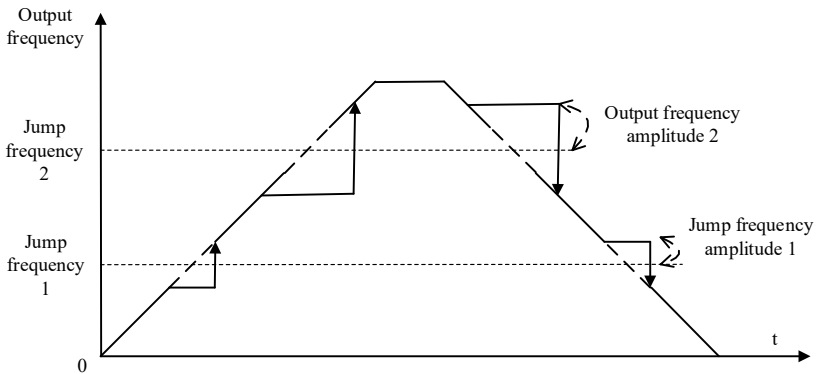

Jump frequency and range diagram

**Tips:** During acceleration and deceleration, the output frequency of the inverter will still pass through the jump frequency zone normally.



### 6.3 F2: Switching Value Terminal Parameters

F02.00	Input terminal 1(X1)	Setting range: 0~63	Default: 1
F02.01	Input terminal 2(X2)		Default: 2
F02.02	Input terminal 3(X3)		Default: 80
F02.03	Input terminal 4(X4)		Default: 81
F02.04	Input terminal 5(X5)		Default: 82
F02.05	Input terminal 6(X6 expand)		Default: 0
F02.06	Input terminal 7(X7 expand)		Default: 0
F02.07	Input terminal 8(X8 expand)		Default: 0
F02.08	Input terminal 9(X9 expand)		Default: 0
F02.09	Input terminal 10(X10 expand)		Default: 0

This unit has 5 multi-function input terminals.

The functions of the multi-function input terminals (X1-X10) can be defined separately by the parameters [F02.00~F02.09].

Set the characteristics of the multi-function input terminal and the detection delay by parameter [F02.11~F02.22]. For details, see parameter [F02.11~F02.22].

Set the terminal characteristics of the multi-function input terminal [X5/PUL] with parameter [F02.04]. When set to "39: Frequency selection", the external terminal is a high-speed pulse port, which is used as a PUL reference function; otherwise, the external terminal is a digital signal input port, which is used as an X5 input. ([F02.09] Multi-function terminal X10/PUL settings are the same)

The multi-function input terminals are versatile and can be easily set and selected as needed. The set values and functions are as follows:

X	Function Specification	X	Function Specification
0	No function	32	ACC/DEC time selection terminal 1
1	FWD	33	ACC/DEC time selection terminal 2
2	REV	34	ACC/DEC pause
3	3-line running(Xi)	35	Swing frequency input
4	FWD JOG	36	Swing frequency pause
5	REV JOG	37	Swing frequency reset
6	Free stop	40	Timer trigger terminal
7	Emergency stop	41	Timer clear terminal
8	Malfunction reset	42	Counter input terminal
9	External malfunction input	43	Counter clear terminal
10	Frequency increase UP	44	DC braking command
11	Frequency decrease DW	45	Pre excitation command terminal
12	UP/DW clear	46	Motor selection terminal
13	Switch channel A to channel B	48	Command channel switch to keyboard
14	Channel combination switch to A	49	Command channel switch to terminal
15	Channel combination switch to B	50	Command channel switch to

			communication
16-19	Multispeed terminal 1-4	51	Command channel switch to expansion card
20	PID control cancel	52	Operation banned
21	PID control pause	53	Forward banned
22	PID trait switch	54	Reverse banned
23	PID parameter switch	60	Speed torque control switch
24-26	PID given switch 1-3	61	Control mode switch to position control
27-29	PID feedback switch 1-3	62-79	Reserve
30	PLC pause	80	Water-full detect alarm
31	PLC restart	81	Water-full detect alarm recovery
		82	Hybrid mode
		83	Dry running input

**0: no function**

Indicates that the terminal is invalid. If the terminal function is idle, it is recommended to set it to “0” to prevent misoperation.

**1: Forward running**

When the running command is given by the terminal, if [F02.23] is set to “0: two-wire system 1”, the inverter will run forward when the terminal is valid. For other control modes, see parameter [F02.23]; Start the protection feature reference parameter [F02.24].

**2: Reverse running**

When the running command is given by the terminal, if [F02.23] is set to “0: two-wire system 1”, the inverter will run in reverse when the terminal is valid. For other control modes, see parameter [F02.23]; Start the protection feature reference parameter [F02.24].

**3: Three-wire operation control (Xi)**

When the running command is given by the terminal, if [F02.23] is set to “2(3): three-wire system 1(2)”, the terminal is the three-wire operation control terminal (Xi). For details, see parameter [F02.23]; At the same time, the startup protection feature is invalid. For details, see parameter [F02.24]

**4: Forward turning****5: Reverse jog**

Positive and negative jog command input port. When this terminal is valid, the inverter will jog. The terminal jog command has the highest priority. See [F01.38~F01.40] for detailed setting of jog parameters and reference parameter [F02.24] for jog protection characteristics.

**6: Free parking**

When the terminal is valid, the inverter immediately blocks the output, and the motor is in free running state.

When the free stop terminal is always active, the drive will not accept any start command and remain stopped.

When the keyboard, RS485, optional card and terminal three-wire control are running, after the free stop terminal command is released, the original operation command will not be restored. If the inverter needs to be started, the operation command must be re-entered.

**7: Emergency stop**

If an emergency stop command is input during the operation of the inverter, the inverter will decelerate to

a stop with the deceleration time set by [F01.27]. For details, please refer to [F01.27] Emergency stop deceleration time.

After entering the emergency stop command, it cannot be re-run until the inverter has completely stopped. If the stop mode [F01.10] is set to free stop, the inverter will still perform emergency stop deceleration according to the emergency stop time.

When the emergency stop terminal is always active, the inverter will not accept any start command and keep the stop command status. When the terminal two-wire control is running, whether the original operation command is restored after the emergency stop terminal command is released, refer to the parameter setting of [F02.24].

When the keyboard, communication, optional card and terminal three-wire control are running, the original stop command is not restored after the emergency stop terminal command is released. To start the drive, you need to re-enter the run command.

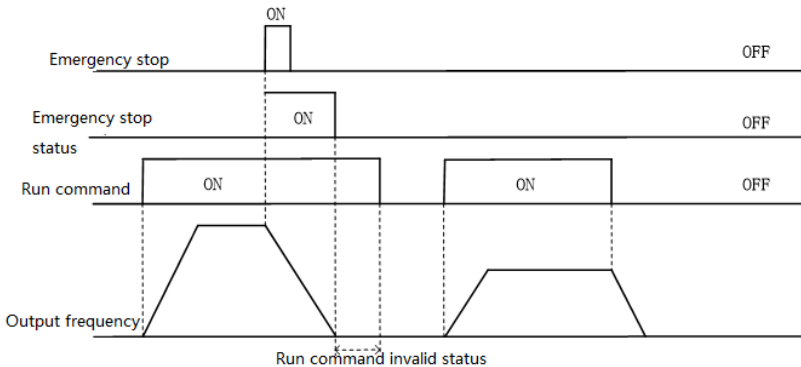

Emergency stop command diagram

**Notes:** Sudden deceleration can cause the inverter to generate an overvoltage fault. When an overvoltage fault occurs, the output of the inverter will be cut off and the motor will run freely, which will cause the motor to be out of control. Therefore, when using the emergency stop function, set the appropriate deceleration time in [F01.27] or use it with the energy consumption brake function.

**8: Fault reset**

When the inverter has a fault alarm, the fault can be reset through this terminal. When the two-wire control of the terminal is running, whether the original operation command is restored after the fault is reset, refer to the parameter setting of [F02.24].

**9: External fault input**

Through this terminal, the fault signal of the external device can be input, which is convenient for the inverter to monitor and protect the fault of the external device. After the inverter receives the external fault input signal, it immediately blocks the output, the motor is in free running state, and the fault information E.EF is displayed.

**10: Frequency increment (UP)**

**11: Frequency decrement (DW)**

The increment (UP) and decrement (DW) of a given frequency are achieved by the control terminals. Only valid when parameter [F00.03] is set to "7" terminal UP/DW control.

You can set the memory and clear mode after adjusting the frequency by UP and DW through [F02.34]. For details, see parameter [F02.34];

The acceleration/deceleration rate of the given frequency can be controlled by the [F02.35] setting terminal UP/DW. For details, see parameter [F02.35].

**12: Frequency increment decrements clear (UP/DW clear**

UP, DW adjustment frequency can be cleared at any given time by the "frequency increment decrement clear (UP / DW clear)" terminal to clear its given frequency.

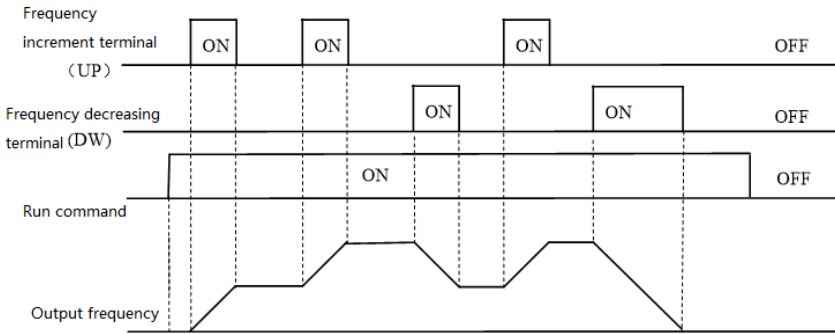

Terminal increase or decrease frequency diagram

### 13: Channel A switches to channel B

### 14: Frequency channel combination is switched to channel A

### 15: Frequency channel combination is switched to B

The frequency is given to the fixed channel combination through the terminal.

### 16: multi-speed terminal 1

### 17: Multi-speed terminal 2

### 18: Multi-speed terminal 3

### 19: Multi-speed terminal 4

The input port of the multi-speed command, the code combination realizes 15 speeds; the multi-speed command has priority next to the jog command. For details, see the setting instructions of the [F12.00~F12.14] parameters.

### 20: PID control canceled

When the terminal is valid, the process PID function can be disabled, the PID output and internal state are forcibly cleared. When the terminal is invalid, the PID restarts calculation.

### 21: PID control pause

When the terminal is valid, the process PID function can be suspended, and the PID output and internal state maintain the current value. When the terminal is invalid, the PID continues to operate based on the current value.

### 22: PID feature switching

When this terminal is valid, the PID feedback characteristic of the LED bit setting of parameter [F11.07] will change. When the terminal is invalid, the PID output characteristic will be changed to the PID of the LED bit setting of [F11.07]. Feedback characteristics.

### 23: PID parameter switching

This terminal selection is valid when the PID parameter switching condition [F11.17] is set to "1". When the function is invalid, the PID adjustment ratio, integral, and derivative parameters are [F11.11~F11.13], and when valid, [F11.14~F11.16].

### 24: PID given switch 1

### 25: PID given switch 2

### 26: PID given switch 3

When the PID controller's given signal source [F11.00] is set to "8" terminal selection, the channel of the PID controller's given signal source is switched through the group terminal. For details, see parameter [F11.00]

**27: PID feedback switch 1**

**28: PID feedback switch 2**

**29: PID feedback switch 3**

When the PID controller feedback signal source [F11.03] is set to "8" terminal selection, the channel of the PID controller feedback signal source is switched through this group terminal. For details, see parameter [F11.03].

**30: Program operation (PLC) is suspended**

When the frequency reference main channel selection [F00.03] is set to "9: Program control (PLC) reference", during the running of the program, the signal is valid to suspend the program operation, and the inverter runs at the current segment frequency. After the signal disappears, it continues to run in the state before the pause. For detailed parameters of the program control (PLC), see the multi-speed and PLC function "F12" group parameters.

**31: Program operation (PLC) restart**

When the frequency reference main channel selection [F00.03] is set to "9: Program control (PLC) reference", the signal is valid to restart the program during the stop status and program operation, from the first The phase begins to run. For detailed parameters of the program control (PLC), see the multi-speed and PLC function "F12" group parameters.

**32: Acceleration/deceleration time selection terminal 1**

**33: Acceleration/deceleration time selection terminal 2**

The acceleration/deceleration time selects the command input port, and the coding combination realizes the selection of the 4-stage acceleration/deceleration. When the parameter is not set and the terminal is invalid, the default selection is that the acceleration/deceleration time 1 is valid. See the detailed description of the parameters [F01.21~F01.26] for details.

**34: Acceleration/deceleration pause** In the inverter running state, when the terminal is valid, the inverter stops acceleration and deceleration and keeps the current speed unchanged.

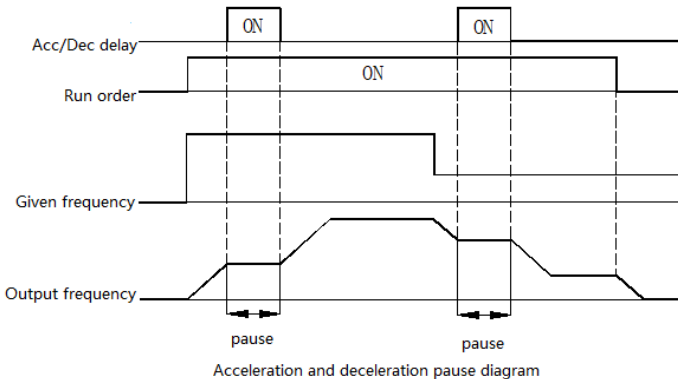

**35: Swing frequency input**

In the swing frequency control, if it is set to manual input, when the terminal is valid, the swing frequency function is valid and the inverter starts the swing frequency operation. See parameter [F12.49~F12.55] for details.

**36: swing frequency pause**

During the swing frequency control, when the terminal is valid, the inverter keeps the current output frequency unchanged. After the terminal command is cancelled, the swing frequency operation is resumed. See parameter [F12.49~F12.55] for details.

**37: swing frequency reset**

During swing frequency control, when the terminal generates a valid edge delay (invalid to active state), the inverter first returns to the center frequency and then re-enters the swing frequency operation. See parameter [F12.49~F12.55] for details.

**38: keyboard self-test**

When the input port is valid, the keyboard enters the self-test interface.

**39: Frequency selection**

The X10 terminal on the control board or the X10 terminal on the expansion card is changed to a high-speed pulse port as a PUL input port.

**40: Timer trigger terminal**

The port is that starts the timer to start the timer operation, and triggers the timing when the terminal is valid. See parameter [F02.37~F02.38] for details.

**41: Timer clear terminal**

The timing record of the timer is cleared when the terminal is valid. See parameter [F02.37~F02.38] for details.

**42: Counter clock input terminal**

For the clock input terminal of the counter function, see parameter [F02.39~F02.40].

**43: Counter clear terminal**

When the terminal is valid, clear the counter record of the counter. For details, see parameter [F02.39~F02.40].

**44: DC braking command**

When the inverter is stopped, the DC braking function of the inverter can be started. For the current during DC braking, refer to the setting value of the DC braking current for the stop [F01.12]. If a run or jog command is input, the DC brake will be released.

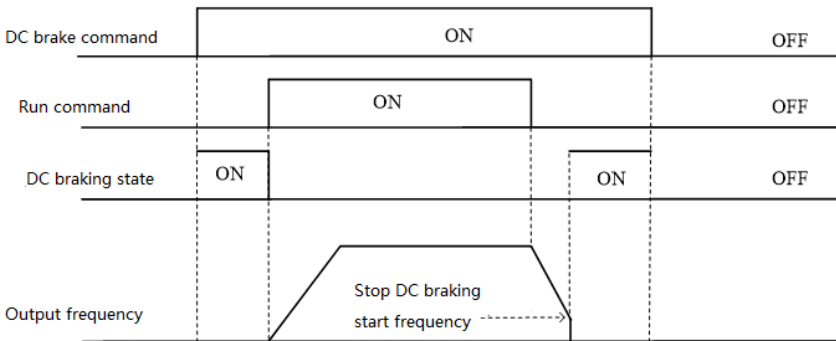

DC braking command diagram

**45: Pre-excitation command terminal**

This function is only valid during asynchronous machine vector control. When the inverter is stopped, the pre-excitation function of the inverter can be started. If a run or jog command is input, the pre-excitation will be released.

**46-47: Reserved**

**48: Command channel switches to keyboard**

**49: Command channel is switched to the terminal**

**50: Command channel switches to communication**

**51: Command channel switch to expansion card**

The command channel switching terminal can be switched to 4 kinds of command settings. The effective priority of the terminal is keyboard, terminal, communication, and expansion card from high to low.

**52: Run prohibition**

**53: Forward prohibition**

**54: Reverse prohibition**

When the operation prohibition terminal selection is valid, the running command in the stop state is invalid, and the running state is free to stop;

When the forward rotation prohibition terminal selection is valid, the forward rotation running command is invalid in the stop state, and the free running is stopped in the forward running state;

When the reverse prohibition terminal selection is valid, the reverse running command is invalid in the stop state, and the free running is stopped in the reverse running state;

**55-59: Reserved**

**60: Speed torque control switching**

This function is valid under vector control. When the terminal is valid, the motor is switched from speed control to torque control.

**61: Position control switching**

This function is valid only under closed loop vector control. When the terminal is valid, the motor control mode is switched to the position control mode; the effective priority of the terminal is greater than the speed torque control switching.

**61-69: Reserved**

**80: Water-full detect alarm**

**Solar water full detection alarm that is the upper limit; Application-specific view of water-full protection parameters (F14.27)**

**81: Water-full detect alarm recovery**

**Solar water full detection alarm reset that is the lower limit**

**82: Hybrid mode**

**When the PV AC and DC will be input at the same time, this function needs to be turned on**

**83: Dry running input**

**External terminal trigger hit dry fault, need to set F14.29**

F02.10	X1 ~ X4 terminal trait selection	Setting range: 0000~1111	Default: 0000
--------	----------------------------------	--------------------------	---------------

**X1 to X4 terminal characteristic selection:** The characteristics of the multi-function input terminals X1, X2, X3, and X4 are set separately.

**LED “0” digit: X1 terminal**

**LED “00” digit: X2 terminal**

**LED “000” digit: X3 Terminal**

**LED “0000” digit: X4 Terminal**

0: Closed valid



1: disconnection is valid

F02.11	X5 ~ X8 terminal trait selection	Setting range: 0000~1111	Default: 0000
F02.12	X9 ~ X10 terminal trait selection	Setting range: 0000~1111	Default: 0000

The terminal characteristics are selected as above.

F02.13	X1 valid detection delay	Setting range: 0.000~6.000s	Default: 0.010
F02.14	X1 invalid detection delay	Setting range: 0.000~6.000s	Default: 0.010
F02.15	X2 valid detection delay	Setting range: 0.000~6.000s	Default: 0.010
F02.16	X2 invalid detection delay	Setting range: 0.000~6.000s	Default: 0.010
F02.17	X3 valid detection delay	Setting range: 0.000~6.000s	Default: 0.010
F02.18	X3 invalid detection delay	Setting range: 0.000~6.000s	Default: 0.010
F02.19	X4 valid detection delay	Setting range: 0.000~6.000s	Default: 0.010
F02.20	X4 invalid detection delay	Setting range: 0.000~6.000s	Default: 0.010
F02.21	X5 valid detection delay	Setting range: 0.000~6.000s	Default: 0.010
F02.22	X5 invalid detection delay	Setting range: 0.000~6.000s	Default: 0.010

**Valid detection delay:** The delay time corresponding to the input terminal X1~X5 transitioning from the invalid state to the active state.

**Invalid detection delay:** The delay time corresponding to the input terminal X1~X5 transitioning from the active state to the inactive state.

F02.23	Terminal control running mode	Setting range: 0~3	Default: 0
--------	-------------------------------	--------------------	------------

This parameter defines four different ways to control the operation of the drive via external terminals.

**0: Two-wire control**

The operation is in one direction. This mode is the most commonly used two-wire mode. The factory default is to determine the forward and reverse running of the motor by the X1 (forward running) and X2 (reverse running) terminal commands. As shown below:

K1	K2	running command
0	0	Stop
1	0	Forward
0	1	Reverse
1	1	Stop

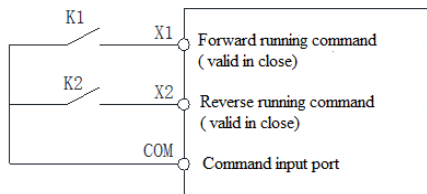

0: Two-wire control 1 schematic

**1: Two-wire control 2:**

The operation is separated from the direction. The forward running terminal X1 (forward running) defined in this mode is the operation enable terminal. The definition of the direction is determined by the state of the reverse running terminal X2 (reverse running). As shown below:

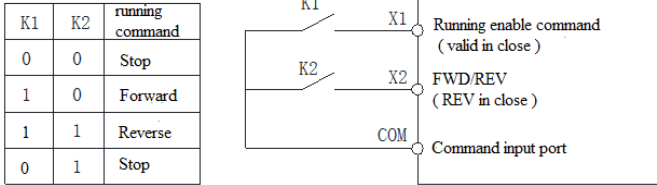

1: Two-wire control 2 schematic

**2: Three-wire control 1:**

In this mode, the three-wire operation control terminal (Xi) is the stop operation terminal, and the running command is generated by the forward rotation operation terminal X1 (forward rotation operation), and the direction is controlled by the reverse rotation operation terminal X2 (reverse rotation operation). The three-wire operation control terminal (Xi) is an effective input.

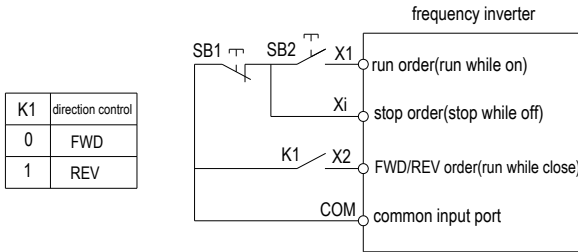

2: 3-line 1

2: Three-wire control 1 schematic

**3: Three-wire control 2:**

In this mode, the three-wire operation control terminal (Xi) is the stop operation terminal, and the operation command is generated by the forward rotation operation terminal X1 (forward rotation operation) or the reverse operation terminal terminal X2 (reverse rotation operation), and both control the running direction.

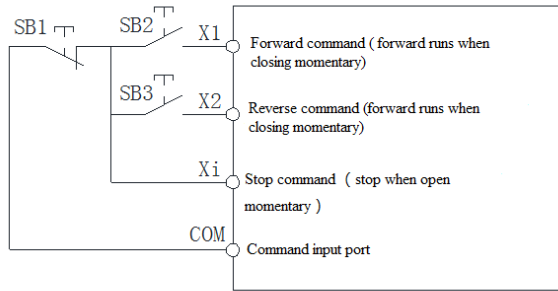

3: Three-wire control 2 schematic

**Tips:** SB1: Stop button; SB2: Forward run button; SB3: Reverse run button; "Xi" is multi-function input terminal set to "3" [3-wire operation control (Xi)].

F02.24	Terminal operate protection	Setting range: 0000~0111	Default: 0111
--------	-----------------------------	--------------------------	---------------

**Terminal Start Protection:**

An abnormality in the inverter causes a shutdown and protects the validity of the terminal command.

When the abnormality disappears, the terminal signal does not change before the abnormality occurs. At this time, if the protection is turned off, the inverter considers that the terminal command continues to be valid and runs according to the given command; if the protection is turned on, the inverter considers that the terminal command is invalid, and must first The terminal command is undone before it can respond to the new terminal command.

The protection terminal includes: a start command terminal, a jog terminal, and a command channel switch terminal.

Abnormal conditions include: fault, undervoltage, or external abnormal shutdown commands.

**LED “0” digit: terminal start protection when exiting abnormal**

- 0: off
- 1: open

The above status is valid only when the terminal control operation [F00.02] is set to "1" and is in the two-wire control mode, that is, when [F02.23] is set to "0" or "1". In the three-wire control mode, the run command must be re-entered.

**LED “00” digit: Jog terminal start protection when exiting abnormal**

- 0: off
- 1: open

**LED “000” digit: Start protection when the command channel is switched to the terminal**

- 0: off
- 1: open

**LED “0000” digit: Reserved**

**Note:** When the start/stop command channel is terminal and the control mode is two-wire type, the terminal running command will be abnormally stopped when the terminal running command is continuously valid. When the abnormality disappears, if the protection is turned off, the inverter will immediately start the motor to enter the running state; if the protection is turned on, the previous running command must be cancelled

before the motor can be started in response to the new running command.

F02.25	Counter input	0: Common X terminal 1: High speed input terminal PUL	2: PG card counting	Default: 0
F02.26	Count input frequency division	0-6000		Default: 0
F02.27	PUL signal source	0: X5(max~5 KHz) 1: Extend interface X10(max~100 KHz) 2: Reserved		Default: 0
F02.28	PUL input min frequency	Setting range: 0.00~50.00kHz		Default: 0.00kHz
F02.29	PUL min frequency corresponding setting	Setting range: 0.00~100.00%		Default: 0.00%
F02.30	PUL input max frequency	Setting range: 0.00~100.00kHz		Default: 100.00kHz
F02.31	PUL max frequency corresponding setting	Setting range: 0.00~100.00%		Default: 100.00%
F02.32	PUL filter time	Setting range: 0.000~9.000s		Default: 0.100s
F02.33	PUL cut-off frequency	Setting range: 0.000~1.000kHz		Default: 0.010kHz

#### **PUL input minimum frequency:**

This function defines the minimum frequency accepted by the pulse input terminal (PUL). Below this frequency signal, the drive will process at the input minimum frequency.

#### **PUL minimum frequency corresponding setting:**

Used to set the percentage of the set value corresponding to the PUL minimum input frequency.

#### **PUL input maximum frequency:**

This function defines the maximum frequency accepted by the pulse input terminal (PUL). Above this frequency signal, the inverter will process at the input maximum frequency.

#### **PUL maximum frequency corresponding setting:**

It is used to set the percentage of the set value corresponding to the maximum input frequency of PUL.

#### **PUL filter time:**

This parameter is defined as the size of the input pulse signal to filter out the interference signal. The longer the filtering time, the stronger the anti-interference ability, but the reaction speed becomes slower; the shorter the filtering time, the weaker the anti-interference ability, but the reaction speed becomes faster.

**PUL cutoff frequency:**

This parameter defines the minimum recognition pulse frequency of the PUL port. Below the pulse frequency of this parameter, the inverter no longer recognizes it and processes it according to the “0Hz” frequency value. The smaller the value is set, the lower the pulse frequency that the PUL port can receive. However, when the PUL port pulse frequency disappears, the inverter determines that the pulse input is “0 Hz” for a longer period of time.

F02.34	UP/DW terminal control mode	Setting range: 0~2	Default: 0
F02.35	ACC/DEC speed of UP/DW terminal frequency control	Setting range: 0.01~50.00Hz/s	Default: 0.50Hz/s
F02.36	Reserved		

**Terminal UP/DW control mode:**

**0: Power-down shutdown storage** When the terminal UP/DW is adjusted, the frequency record is maintained after the machine is powered off or stopped. During power-on operation, the inverter performs UP/DW adjustment operation from the frequency at the last stop.

**1: Don't save when unenergified and save when stopping** When the terminal UP/DW is adjusted, the frequency record is maintained after the machine stops. During the next run, the inverter performs UP/DW adjustment operation from the frequency at the last stop. Recording is not saved after power failure, starting from 0.00Hz.

**2: Valid when running and clear when stopping** When the terminal UP/DW is adjusted, the frequency record is not maintained after the machine stops or powers off. During the next run, the inverter performs UP/DW regulation operation from a frequency of 0.00 Hz.

**Terminal UP/DW controls the frequency increase and decrease rate:**

This function defines the rate of change of a given frequency when the terminal UP/DW is adjusted.

F02.37	Timer time unit	Setting range: 0~2	Default: 0
F02.38	Timer setting value	Setting range: 0~65000	Default: 0

**Timer time unit:**

This function is used to set the timing unit of the inverter timer.

**0: Second** The timer is timed in seconds.

**1: Minute** The timer is timed in minutes.

**2: Hour** The timer is timed in hours.

**Timer setting:**

This parameter is used to set the timing of the inverter. The timer starts counting when the external trigger terminal receives the valid signal, and after the timing time arrives, the pulse signal with a width of 1 second is output from the corresponding output terminal.

The trigger terminal is determined by the multi-function input terminal selection "40: Timer Trigger Terminal". See [F02.00~F02.12] for details.

The output terminal is determined by the multi-function output terminal selecting "21: Timer time to". See [F02.43~F02.50] for details.

When the trigger terminal is invalid, the timer keeps the existing timing value, and the accumulated timing continues after the trigger terminal is valid.

The timer clear terminal can clear the timing value at any time.

**Tip: The timer can work independently, not limited by the running status of the inverter. When some working conditions require timing, the inverter can be used. The timer, in which the timing time can be displayed in [C00.30], the time unit is determined by [F02.37].**

F02.39	Counter max value	Setting range: 0~65000	Default: 1000
F02.40	Counter setting value	Setting range: 0~65000	Default: 500
F02.41	Reserved		

This parameter specifies the counting action of the internal counter and counts the clock type signal of the counter input terminal.

#### Counter maximum:

When the count value reaches the value specified by parameter [F02.39], the corresponding output terminal outputs a valid signal. The output signal width is equal to the clock period of the valid signal of the external input terminal, that is, when the next count signal is input, the output terminal stops outputting the valid signal.

The input terminal is determined by the multi-function input terminal selection "42: Counter input terminal". See [F02.00~F02.12] for details.

The output terminal is determined by the multi-function output terminal selecting "22: Counter reaches maximum value". See [F02.43~F02.50] for details.

#### Counter setting:

When the count value reaches the value specified by the parameter [F02.40], the valid signal is output at the corresponding output terminal, and the output signal width is the value of the count value exceeding the value specified by the parameter [F02.39], causing the output terminal to be cleared when the counter is cleared. The output of the valid signal is stopped.

The input terminal is determined by the multi-function input terminal selection "42: Counter input terminal". See [F02.00~F02.12] for details.

The output terminal is determined by the multi-function output terminal selecting "23: Counter reaches the set value". See [F02.43~F02.50] for details.

The count value of the counter can be cleared at any time by the counter clear terminal set by the multi-function input terminal [F02.00~2.09].

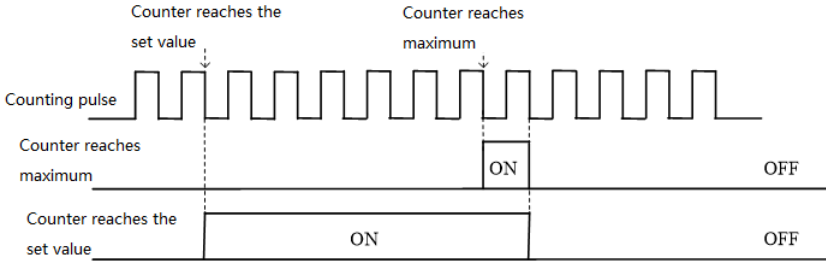

Counter maximum value and counter setting value related operation diagram

**Notes:** The counter can work independently and is not limited by the running status of the inverter. When some working conditions need to be counted, the counter in the inverter can be used, and the counting value can be displayed in [C00.22].

F02.42	Output terminal polarity selection	Setting range: 0000~0111	Default: 0000
--------	------------------------------------	--------------------------	---------------

**LED “0” digit: Y terminal**

- 0: Positive polarity - active state Y output terminal low level, equivalent normally open
- 1: Negative polarity - active state Y output terminal has no output, equivalent normally open

**LED “00” digit: relay output terminal 1**

- 0: Positive polarity TA-TC normally open TB-TC normally closed
- 1: Negative polarity TA-TC normally closed TB-TC normally open

**LED “000” digit: relay output terminal 2**

- 0: Positive polarity TA1-TC1 normally open TB1-TC1 normally closed
- 1: Negative polarity TA1-TC1 normally closed TB1-TC1 normally open

**LED “0000” digit: Reserved**

F02.43	Output terminal Y1	Setting range: 0~31	Default: 1
F02.44	Relay output		Default: 4
F02.45	Extend terminal Y1		Default: 11
F02.46	Extend relay output 2		Default: 11

**Output terminal Y and relay function selection**

**0: no output**

Indicates that the terminal is invalid. If the terminal function is idle, it is recommended to set it to “0” to prevent malfunction.

**1: The inverter is running**

A valid signal is output when the inverter is in operation.

**2: The inverter is running in reverse**

When the inverter is in the reverse running state, a valid signal is output.

**3: The inverter is running in reverse**

When the inverter is in forward running state, it outputs a valid signal.

**4: Fault trip alarm 1 (alarm during fault self-recovery)**

When the inverter is faulty, including the fault self-recovery period, the output signal.

**5: Fault trip alarm 2 (no alarm during self-recovery)**

When the inverter is faulty, it does not include the fault self-recovery period and outputs a valid signal.

**6: External downtime**

When the multi-function input terminal inputs an external fault signal and reports the external fault E. EF of the inverter, it outputs a valid signal.

**7: Inverter undervoltage**

A valid signal is output when the frequency converter is under voltage.

**8: The inverter is ready for operation**

When the signal is valid, it means that the inverter has no fault, the bus voltage is normal, the operation prohibition terminal such as emergency stop or emergency stop of the inverter is invalid, and it can be operated after accepting the start command.

**9: Output frequency level detection 1 (FDT1)****10: Output frequency level detection 2 (FDT2)**

When the output frequency of the inverter exceeds the frequency detection level [F02.51]/[F02.53] setting value, after the hysteresis frequency set by [F02.52]/[F02.54], the valid signal is output. When the output frequency of the inverter is lower than the frequency detection level, the invalid signal is output after the same hysteresis frequency. See the description of parameter [F02.51~F02.54] for details.

**11: the given frequency arrives**

When the output frequency of the inverter approaches or reaches a given frequency to a certain range (the range is determined by parameter [F02.55]), the valid signal is output, otherwise the invalid signal is output. See the description of parameter [F02.55] for details.

**12: running at zero speed**

When the inverter is running and the output is 0.00Hz, a valid signal is output.

**13: The upper limit frequency arrives**

When the inverter runs at the upper limit frequency, it outputs a valid signal.

**14: Lower limit frequency arrival**

When the inverter runs at the lower limit frequency, it outputs a valid signal.

**15: Program running cycle completion** When the program runs one cycle end, it outputs a valid signal of 500ms.

**16: program running phase is completed**

When the program runs at the end of a phase, a valid signal of 500ms is output.

**17: PID feedback exceeds the upper limit**

When the PID feedback amount reaches the upper limit of the disconnection alarm [F11.27], the feedback signal is over-limit after the delay time of [F11.25], and the valid signal is output.

**18: PID feedback is below the lower limit**

When the PID feedback amount reaches the lower limit of the disconnection alarm [F11.28], the feedback signal is over-limit after the delay time of [F11.25], and the valid signal is output.

**19: PID feedback sensor disconnected**

When the PID feedback sensor is disconnected, a valid signal is output. See parameter [F11.25~F11.28].



**20: Reserved****21: Timer time is up**

When the inverter internal timer timing time arrives, the port outputs a valid pulse signal with a width of 1 second. See parameter [F02.37~F02.38].

**22: Counter reaches the maximum value**

When the counter reaches the maximum value, the output terminal outputs a valid signal with a width equal to the external clock cycle, and the counter is cleared. See parameter [F02.39~F02.40].

**23: Counter reaches the set value**

When the counter reaches the set value, the output terminal outputs a valid signal, and continues to count until the counter exceeds the maximum value, causing the counter to be cleared, and the output valid signal is cancelled. See parameter [F02.39~F02.40].

**24: Energy braking**

When the inverter meets the energy consumption braking condition, it outputs a valid signal. See parameter [F04.29] for details.

**25: PG feedback disconnection**

When the PG feedback disconnection is detected, a valid signal is output. See parameter [F05.30~F05.32].

**26: Emergency stop**

When the inverter is in the emergency stop state, a valid signal is output.

**27: Load pre-alarm output 1****28: Load pre-alarm output 2**

When the inverter is running, in the VF control mode, the motor output current is used as the load warning judgment value; in the vector control mode, the motor output torque is used as the load warning judgment value, and the load warning judgment value is compared with the load warning detection level to determine whether Output a valid signal. See parameter [F10.17~F10.21].

**29: Solar-specific alarm output prompts**

When the PV machine alarms (PV-specific alarm), the Y terminal and 24V terminal will output a high voltage signal

**30: RS485 given**

Set by RS485 communication (0x3018/0x2018), BIT0 bit corresponds to Y output, BIT1 corresponds to relay 1 output, and BIT2 bit corresponds to relay 2 output.

F02.47	Y output delay time	Setting range : 0.000~6.000s	Default : 0.010s
F02.48	Extend Y output delay output	Setting range : 0.000~6.000s	Default : 0.010s
F02.49	Relay 1 output delay time	Setting range : 0.000~6.000s	Default : 0.010s
F02.50	Extend relay 2 output delay time	Setting range : 0.000~6.000s	Default : 0.010s

When the internal logic operation of the inverter is to change the state of the Y terminal, the actual state of the Y terminal is output after the set delay time. The delay time precautions are the same as the input terminals.

The relay output terminals are the same.

F02.51	Output frequency level 1(FDT1)	Setting range: 0.00 ~ Maximum frequency	Default: 30.00Hz
F02.52	FDT1 lag	Setting range: 0.00 ~ Maximum frequency	Default: 1.00Hz
F02.53	Output frequency level 2(FDT2)	Setting range: 0.00 ~ Maximum frequency	Default: 50.00Hz
F02.54	FDT2 lag	Setting range: 0.00 ~ Maximum frequency	Default: 1.00Hz

During acceleration, when the output frequency of the inverter exceeds the frequency detection level [F02.51] / [F02.53] setting value, after the hysteresis frequency set by [F02.52]/[F02.54], the output is output. Valid signal; when decelerating, when the output frequency of the inverter is lower than the frequency detection level, after the same hysteresis frequency, the invalid signal is output. The output frequency is detected as shown below:

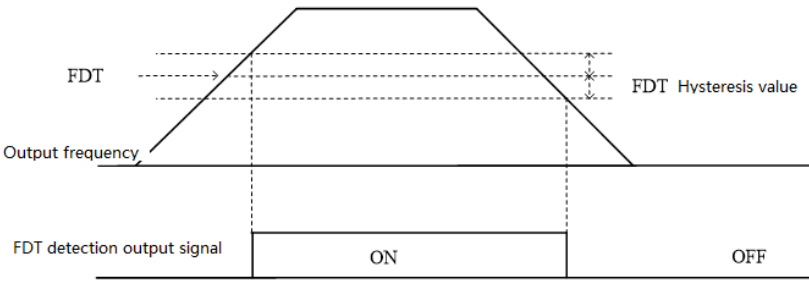

Frequency level detection diagram

F02.55	Given frequency arriving checkout range	Setting range : 0.00 ~ 50.00Hz	Default : 2.00Hz
--------	---	--------------------------------	------------------

When the output frequency of the inverter reaches or approaches a given frequency value, the output terminal (Y/TA-TB-TC) is selected as the "given frequency arrival" output valid signal; this function can adjust the upper and lower deviation of its detection amplitude. Transfer amount. The frequency arrival output is shown below:

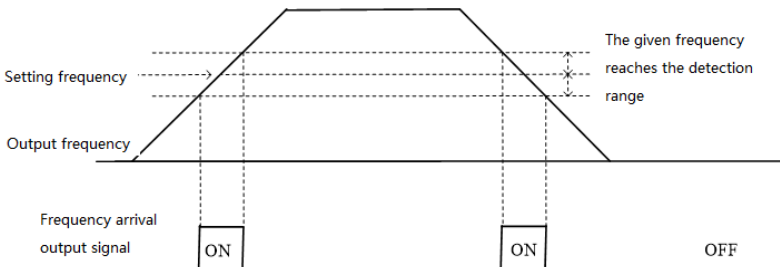

## Frequency arrival detection diagram

F02.55- F02.59	Reserved
----------------	----------

F02.60	Virtual vX1 terminal function selection	Setting range: 0~63	Default: 0
F02.61	Virtual vX2 terminal function selection		
F02.62	Virtual vX3 terminal function selection		
F02.63	Virtual vX4 terminal function selection		

The virtual vX1 to vX4 are identical in function to the multi-function input terminals X1 to X10 and can be used as multi-function digital input. For detailed setting of terminal functions, please refer to [F02.00~F02.09].

F02.64	vX terminal valid state source	Setting range : 0000~1111	Default : 0000
--------	--------------------------------	---------------------------	----------------

**LED “0” digit: virtual vX1**

- 0: Internal connection with virtual vY1
- 1: Link to physical terminal X1
- 2: Is the function code setting valid?

**LED “00” digit: virtual vX2**

- 0: Internal connection with virtual vY2
- 1: Link to physical terminal X2
- 2: Is the function code setting valid?

**LED “000” digit: Virtual vX3**

- 0: Internal connection with virtual vY3
- 1: Link to physical terminal X3
- 2: Is the function code setting valid?

**LED “0000” digit: Virtual vX4**

- 0: Internal connection with virtual vY4
- 1: Link to physical terminal X4
- 2: Is the function code setting valid?

The input status of the virtual vX1~vX4 terminals can be set in three ways, which is selected by [F02.64];

When the state of vX1 to vX4 is connected to the internal connection of virtual vY1 to vY4, whether vX1 to vX4 are valid, depending on whether the output of vY1 to vY4 is valid or invalid, and vX1-vY1; vX2-vY2; vX3-vY3; vX4- vY4 is a one-to-one binding relationship.

When the state of vX1 to vX4 is selected and the physical terminals X1 to X4 are linked, whether vX1 to vX4 are valid or not depends on whether the X1 to X4 inputs are valid or invalid.

When the state of vX1 to vX4 is selected by the function code, whether vX1 to vX4 are valid, the status of the corresponding input terminal can be set by function code [F02.65].

F02.65	Virtual vX terminal function code setting valid state	Setting range : 0000~1111	Default : 0000
--------	---	---------------------------	----------------

**LED “0” digit: virtual vX1**

0: invalid;

1: valid

**LED “00” digit: virtual vX2**

0: invalid;

1: valid

**LED “000” digit: Virtual vX3**

0: invalid;

1: valid

**LED “0000” digit: Virtual vX4**

0: invalid;

1: valid

F02.66	Virtual vY1 terminal function selection	Setting range: 0~31	Default: 0
F02.67	Virtual vY2 terminal function selection		
F02.68	Virtual vY3 terminal function selection		
F02.69	Virtual vY4 terminal function selection		

The virtual terminal vY1~vY4 output function selection is the same as the Y terminal and relay. For details, please refer to [F02.43~F02.46].

F02.70	vY1 output delay	Setting range : 0.000~6.000s	Default : 0.010s
F02.71	vY2 output delay	Setting range : 0.000~6.000s	Default : 0.010s
F02.72	vY3 output delay	Setting range : 0.000~6.000s	Default : 0.010s
F02.73	Virtual vY2 output selection	Setting range : 0.000~6.000s	Default : 0.010s

The virtual terminal vY1~vY4 output delay setting is the same as the Y terminal and relay delay. For details, please refer to [F02.47~F02.50].

The virtual terminal is characterized by the combination of vX<sub>i</sub> and vY<sub>i</sub>. When you want to use the Y terminal output signal as the X terminal input signal, you can use the internal vX<sub>i</sub> and vY<sub>i</sub> virtual connection to achieve the purpose of use, thus saving the actual X and Y terminals for other Aspect use.

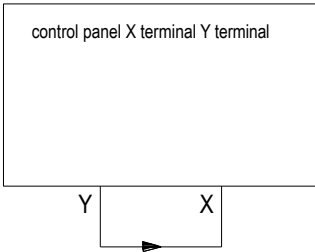

Connecting by external X and Y terminal

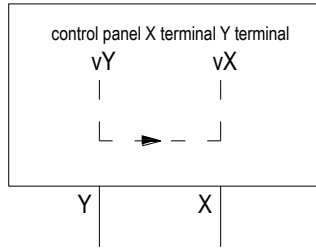

Connecting by virtual terminal internal connection

The following examples illustrate the application of virtual vX and vY:

**Example 1:** In some cases, the inverter is required to run after power-on initialization. In general, an X terminal is used as input.

If you use a virtual terminal, you can save this actual X terminal for other inputs, as follows:

- Set F00.02 = 1 to run the command source terminal control;
- Set F02.23 = 0 two-wire control 1;
- Set F02.60 = 1 terminal input to run in the forward direction;
- Set F02.64 = 0000 The valid state of vX1 is determined by vY1;
- Set F02.66 = 8 Output is output when the inverter is ready for operation.

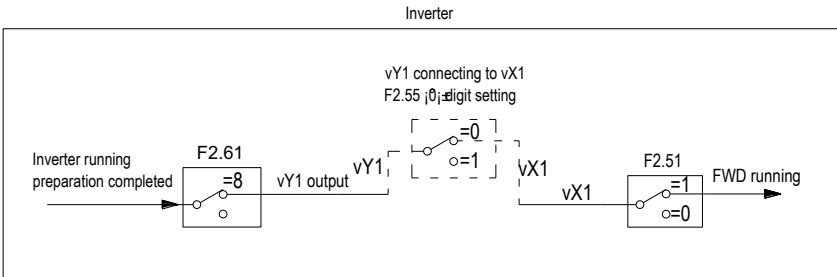

2 line control 1 virtual terminal control

**Example 2:** After the inverter is powered on, the delay is 60s forward running, as follows:

- Set F00.02 = 1 to run the command source terminal control, F02.23 = 2 three-wire control 1;
- Set F02.38 = 60 timer timer 60s;
- Set F02.60 = 1 vX1 terminal function input, forward running;
- Set F02.61 = 3 vX2 terminal function input, three-wire operation control (Xi);
- Set F02.62 = 40 vX3 terminal function input, timer trigger;
- Set F02.64 = 0110 vX2 and vX3 valid status source is determined by F02.64 ten or hundred;
- Set F02.65 = 0110 vX2, vX3 setting is valid;
- Set F02.66 = 21 The vY1 timer counts up to the output.

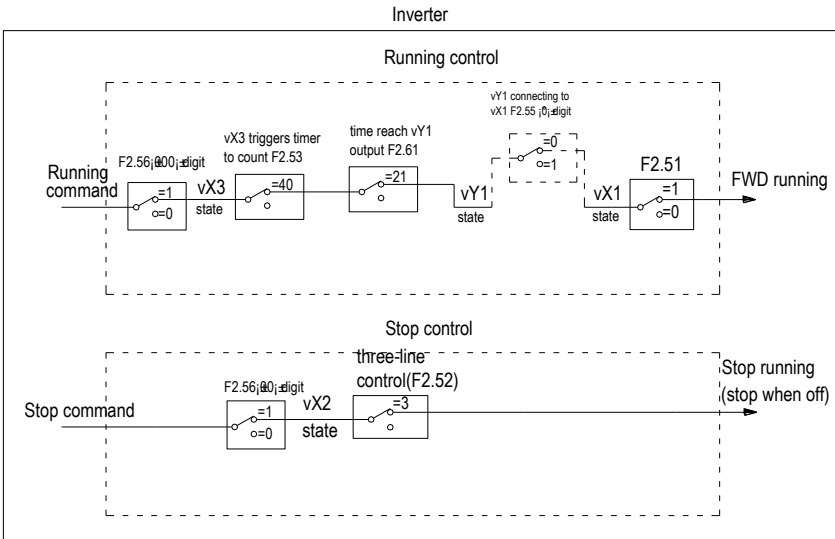

**Notes:** It can be seen from the above figure that the actual method requires access to two actual external X terminals. If virtual terminals are used, no external actual terminals need to be connected

## 6.4 F3: Analog Terminal Parameters

F03.00	A11 Lower limit	Setting range: 0.00~10.00V	Default: 0.00V
F03.01	A11 Lower limit corresponding setting	Setting range: -100.00 ~ 100.00%	Default: 0.00%
F03.02	A11 upper limit	Setting range: 0.00~10.00V	Default: 10.00V
F03.03	A11 upper limit corresponding setting	Setting range: -100.00 ~ 100.00%	Default: 100.00%
F03.04	A11 filter time	Setting range: 0.00~6.000s	Default: 0.100s
F03.05	Reserved		

Analog type The voltage or current input can be selected via the on-board switch. See Section 3.6 Switching Function Description for Electrical Installation.

### A11 lower limit:

This function defines the signal accepted by the analog input terminal (A11). If the voltage signal is lower than this value, the inverter will process according to the lower limit of A11.

### The A11 lower limit corresponds to the setting:

It is used to set the percentage of the set value corresponding to the A11 lower limit input analog quantity.

### A11 upper limit:

This function defines the signal accepted by the analog input terminal (A11). If the voltage signal exceeds this value, the inverter will process according to the upper limit of A11.

### The A11 upper limit corresponds setting:

It is used to set the percentage of the set value corresponding to the A11 upper limit input analog quantity.

### A11 filtering time:

This parameter is defined as the size of the (A11) input analog signal to filter out the interference signal. The longer the filtering time, the stronger the anti-interference ability, but the reaction speed becomes slower; the shorter the filtering time, the weaker the anti-interference ability, but the reaction speed becomes faster.

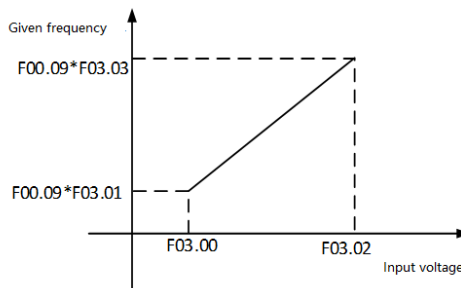

**Tips:** Set the frequency source to select A11 timing, the set frequency can be adjusted to a negative value, and

the [F00.16] hundred-bit selection frequency control direction can be matched to perform bipolar adjustment.

F03.06	AI2 Lower limit	Setting range: 0.00~10.00V	Default: 0.00V
F03.07	AI2 Lower limit corresponding setting	Setting range: -100.00 ~ 100.00%	Default: 0.00%
F03.08	AI2 upper limit	Setting range: 0.00~10.00V	Default: 10.00V
F03.09	AI2 upper limit corresponding setting	Setting range: -100.00 ~ 100.00%	Default: 100.00%
F03.10	AI2 filter time	Setting range: 0.00~10.00s	Default: 0.100s
F03.11	Reserved		

See the description of AI1.

F03.12	AI1 function selection	Setting range: 0~63	Default: 0
F03.13	AI1 high level setting	0.00~100.00%	70.00%
F03.14	AI1 low level setting	0.00~100.00%	30.00%
F03.15	AI2 function selection	Setting range: 0~63	Default: 0
F03.16	AI2 high level setting	0.00~100.00%	70.00%
F03.17	AI2 low level setting	0.00~100.00%	30.00%

The function selection of AI1 and AI2 terminals is the same as the multi-function input X1~X10 on the control panel. It can be used as a multi-function digital input. For detailed settings, please refer to [F02.00~F02.09].

AI1, AI2 high level setting: The port sampling value is considered to be high level if it is greater than or equal to the set value.

AI1, AI2 low level setting: The port sampling value is considered to be low level if it is less than or equal to the set value.

The AI1 port sampling filter value is adjusted by the curve, 0.00~10.00V corresponds to 0~100.00%

The AI1 port sampling filter value is adjusted by the curve, 0.00~20.00 MA corresponds to 0~100.00%

If AI is used as voltage input, 0.00~10.00V corresponds to 0~100.00%.

If AI is used as current input, 0.00~20.00 MA corresponds to 0~100.00%

F03.18	Valid state setting when analog used as terminal	Setting range: 0000~0011	Default: 0000
--------	--	--------------------------	---------------

#### LED "0" digit: AI1

0: low level

1: high level

#### LED "00" digit: AI2

0: low level

1: high level



LED “000” digit: Reserved

LED “0000” digit: Reserved

F03.19	Analog input curve selection	Setting range: 0000~0222	Default: 0000
--------	------------------------------	--------------------------	------------------

LED “0” digit: AI1

LED “00” digit: AI2 (selectable voltage or current input via switch on the control board)

**0: Straight line** By default, the usual two-point line can be referred to the “analog given frequency diagram” above.

**1: Curve 1 Multi-point stitching** please see the description of function code [F03.21~F03.28].

**2: Curve 2 Multi-point stitching** please see the description of function code [F03.29~F03.36].

F03.21	Curve 1 lower limit	Setting range: 0.00~10.00V	Default: 0.00V
F03.22	Curve 1 lower limit corresponding setting	Setting range: 0.00 ~ 100.00%	Default: 0.00%
F03.23	Curve 1 inflection point 1 input voltage	Setting range: 0.00~10.00V	Default: 3.00V
F03.24	Curve 1 inflection point 1 corresponding setting	Setting range: 0.00 ~ 100.00%	Default: 30.00%
F03.25	Curve 1 inflection point 2 input voltage	Setting range: 0.00~10.00V	Default: 6.00V
F03.26	Curve 1 inflection point 2 corresponding setting	Setting range: 0.00 ~ 100.00%	Default: 60.00%
F03.27	Curve 1 upper limit	Setting range: 0.00~10.00V	Default: 10.00V
F03.28	Curve 1 upper limit corresponding setting	Setting range: 0.00 ~ 100.00%	Default: 100.00%
F03.29	Curve 2 lower limit	Setting range: 0.00~10.00V	Default: 0.00V
F03.30	Curve 2 lower limit corresponding setting	Setting range: 0.00 ~ 100.00%	Default: 0.00%
F03.31	Curve 2 inflection point 1 input voltage	Setting range: 0.00~10.00V	Default: 3.00V
F03.32	Curve 2 inflection point 1 corresponding setting	Setting range: 0.00 ~ 100.00%	Default: 30.00%
F03.33	Curve 2 inflection point 2 input voltage	Setting range: 0.00~10.00V	Default: 6.00V
F03.34	Curve 2 inflection point 2 corresponding setting	Setting range: 0.00 ~ 100.00%	Default: 60.00%
F03.35	Curve 2 upper limit	Setting range: 0.00~10.00V	Default: 10.00V
F03.36	Curve 2 upper limit corresponding setting	Setting range: 0.00 ~ 100.00%	Default: 100.00%

Curve 1 and curve 2 can set two inflection points, which are divided into three straight lines. The slope of each segment can be different, which can achieve a more flexible correspondence, as shown in the following figure:

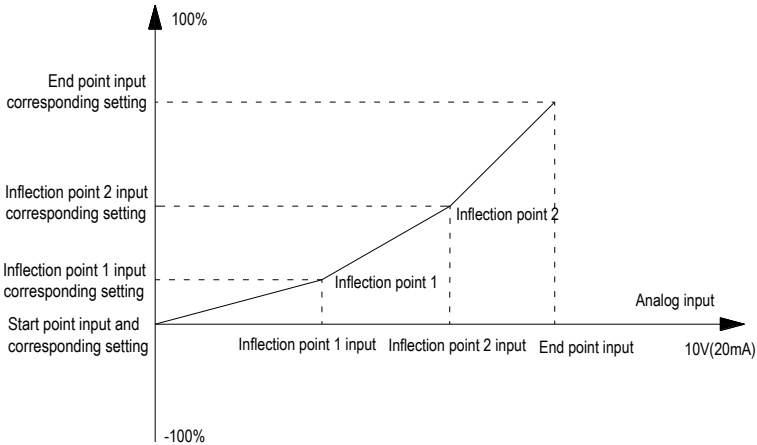

Multi-point curve diagram

If AI1 or AI2 selects curve 1 or curve 2, the current is converted into voltage to set the current to twice the voltage. 4mA corresponds to 2V, and 20mA corresponds to 10V.

**Notes:** [F03.21, F03.23, F03.25, F03.27] and [F03.29, F03.31, F03.33, F03.35] voltage input values must be set incrementally.

F03.37	A0 output signal selection	Setting range: 0000~0032	Default: 0000
--------	----------------------------	--------------------------	---------------

**LED “0” digit: AO1**

- 0:0~10V
- 1:4.00~20.00mA
- 2: 0.00 to 20.00 mA
- 3: FM frequency pulse output

**LED “00” digit: extended AO2**

- 0:0~10V
- 1:4.00~20.00mA
- 2: 0.00 to 20.00 mA

Specify the output signal type of AO and extended AO2 terminals respectively, and select voltage output and current output; AO can also be used as pulse output. Extended AO2 is temporarily not supported.

**Tip:** After the parameter selection output mode, you need to toggle the corresponding DIP switch to achieve the corresponding output. For example, the AO output is the voltage. At this time, F03.37 is set to 0, and F03.38 is set to the corresponding monitoring amount. DIP switch A0-U can be turned ON. For example, the analog DIP switch diagram is described in section 3.6.

F03.38	A01 output selection	Setting range: 0~18	Default: 0
--------	----------------------	---------------------	------------

F03.39	A02 extended output selection		Default: 1
--------	-------------------------------	--	------------

It is used to set the inverter monitoring quantity corresponding to the multi-output terminal (AO) and (AO2) output signals.

The signal type of the (AO) output is set by [F03.37] "0" digit.

The signal type of (AO2) output is set by [F03.38] "00" digit.

Set value	Monitoring amount	Function Description	AO minimum output	AO maximum output
0	Given frequency	Corresponds to the given frequency of the current inverter	The minimum output corresponds to 0.00Hz	Maximum output corresponds to maximum frequency
1	Output frequency	Corresponds to the output frequency of the current inverter	The minimum output corresponds to 0.00Hz	Maximum output corresponds to maximum frequency
2	Output current	Corresponds to the output current of the current inverter	The minimum output corresponds to 0.00A	The maximum output corresponds to 2 times the rated current of the inverter
3	Input voltage	Corresponds to the input voltage of the current inverter	The minimum output corresponds to 0V	The maximum output corresponds to 2 times the rated voltage of the inverter
4	Output voltage	Corresponding to the output voltage of the current inverter	The minimum output corresponds to 0V	The maximum output corresponds to the rated voltage of the inverter
5	Machine speed	Corresponding to the mechanical speed corresponding to the output frequency of the current inverter	The minimum output corresponds to 0rpm	The maximum output corresponds to the speed corresponding to the maximum frequency
6	Given torque	Corresponding to the output torque of the current inverter	The minimum output corresponds to a torque of 0.00%	The maximum output corresponds to 200% of the torque
7	Output torque	Corresponding to the output torque of the current inverter	The minimum output corresponds to a torque of 0.00%	The maximum output corresponds to 200% of the torque

8	PID given value	Corresponding to the PID given by the current inverter	The minimum output corresponds to 0.00% PID given	The maximum output corresponds to 100% PID given
9	PID feedback value	Corresponding to the PID feedback amount of the current inverter	The minimum output corresponds to 0.00% PID feedback	The maximum output corresponds to 100% of the PID feedback amount
10	Output power	Corresponds to the output power of the current inverter	The minimum output corresponds to 0 power	Maximum output corresponds to rated output power
11	Bus voltage	Corresponds to the input voltage of the current inverter	The minimum output corresponds to 0V	The maximum output corresponds to twice the rated DC voltage of the inverter
12	AI1	Corresponds to the current AI1 input value of the inverter	The minimum output corresponds to the AI1 input lower limit	The maximum output corresponds to the upper limit of the AI1 input.
13	AI2	Corresponds to the current AI input value of the inverter	The minimum output corresponds to the AI input lower limit	The maximum output corresponds to the upper limit of the AI input.
14	AS input	Corresponds to the AS input value of the current inverter	The minimum output corresponds to the AS input lower limit	The maximum output corresponds to the upper limit of the AS input.
15	PULoutput value	Corresponds to the PUL input value of the current inverter	The minimum output corresponds to the PUL input lower limit	The maximum output corresponds to the upper limit of the PUL input.
16	Module temperature 1	Corresponds to the module temperature 1 of the current inverter	The minimum output corresponds to the module temperature 1 is 0 degrees Celsius	The maximum output corresponds to the module temperature 1 is 100 degrees Celsius
17	Module temperature 2	Corresponds to the module temperature 2 of the current inverter	The minimum output corresponds to the module temperature 2 is 0 degrees Celsius	The maximum output corresponds to module temperature 2 of 100 degrees Celsius
18	RS485 given	AO address 0x3019 /0x2019 AO2 address 0x301A /0x201A	Minimum output corresponds to 0	The maximum output corresponds to 1000

F03.40	A01 output gain	Setting range : 0.0~200.0%	Default : 100.0%
F03.41	A01 analog output signal bias	Setting range : -10.0~10.0%	Default : 0.0%
F03.42	A01 output filter	Setting range : 0.000~6.000s	Default : 0.010s

**AO output gain:**

The value used to adjust the analog output of the (AO) terminal.

**A0 output signal offset:**

Used to adjust the zero point of the (AO) terminal output signal.

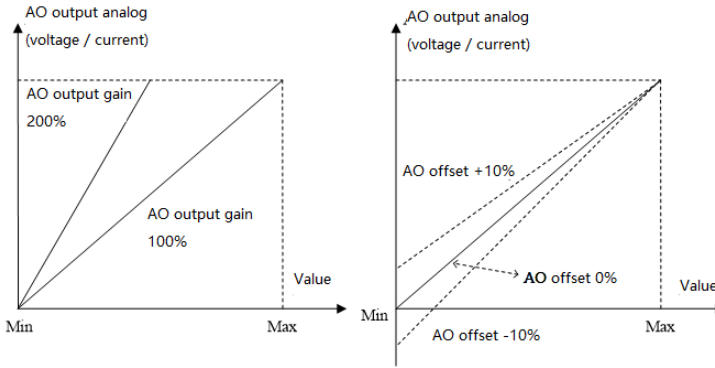

AO analog output and gain, offset schematic

**A0 output filtering:**

This parameter is defined as the size of the AO1 output analog signal filtered to eliminate the interference signal. The longer the filtering time, the stronger the anti-interference ability, but the reaction speed becomes slower; the shorter the filtering time, the weaker the anti-interference ability, but the reaction speed becomes faster.

F03.43	A01 FM frequency output lower limit	Setting range: 0.00 ~ 100.00kHz	Default: 0.20kHz
F03.44	A02FM frequency output upper limit	Setting range: 0.00 ~ 100.00kHz	Default: 50.00kHz

Set the lower and upper frequency values of the output signal when AO is output at the FM frequency pulse.

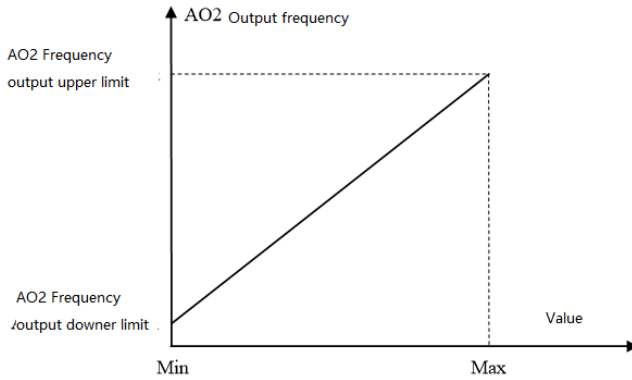

AO2 port pulse frequency output diagram

F03.45	AO2 extend output gain	Setting range: 0.0~200.0%	Default: 100.0%
F03.46	AO2 extend analog output signal bias	Setting range: -10.0~10.0%	Default: 0.0%
F03.47	AO2 extend output filter	Setting range: 0.000~6.000s	Default: 0.010s

See the AO related parameter description.

## 6.5 F4: Keyboard and Display Parameters

F04.00	Parameter and key lock selections	Setting range: 0~3	Default: 0
--------	-----------------------------------	--------------------	------------

### 0: not locked

The parameter and key lock function are invalid.

### 1: function parameter lock

The setting values of all function parameters are locked, and the parameters are prohibited from being modified (except F00.08, which can be modified by the up and down keys). The keyboard cannot enter the modification parameter interface, and the keyboard monitoring amount can be selected by the shift key.

All key functions on the keyboard are not locked.

### 2: Function parameters and key lock (except RUN/STOP).

The setting values of all function parameters are locked, and it is prohibited to modify the parameters (including F00.08, which cannot be modified by the up and down keys). The keyboard cannot enter the modification parameter interface, and the keyboard monitoring amount cannot be selected by the shift key.

Lock all keys on the keyboard except RUN/STOP.

### 3: Function parameters and button full lock

The setting values of all function parameters are locked, and the parameters are prohibited from being modified. The keyboard cannot enter the modification parameter interface, and the keyboard monitoring amount cannot be selected by the shift key.

Lock all keys on the keyboard except PRG.

#### Tips:

- **Double-line digital tube keyboard unlocking method:** Double-line digital tube keyboard After pressing the “PRG” menu button, the first line of the keyboard displays “CodE”. You can use the up and down keys to enter the user password (F04.01 - user password) in the second line and then press the “SET” button to unlock.
- **Single-line digital tube keyboard unlocking method:** Single-line digital tube keyboard displays “CodE” after pressing “PRG” menu button. Then press the “SET” button to display the flashing input cursor. Enter the user password (F04.01—user password) through the up and down keys and press the “SET” button again to confirm.
- The user password is a protective parameter set by the customer to protect the inverter parameters arbitrarily tampering. After the password is set, the password should be properly kept in case it is inconvenient to modify the parameters later.

F04.01	User password	Setting range: 0~9999	Default: 0
--------	---------------	-----------------------	------------

Used to set the user password. When the parameter and key lock selection [F04.00] is locked (not "0"), you must enter the password to unlock. The factory default password is 0. Please keep the set password safe.

F04.02- F04.04	Reserved
-------------------	----------

F04.05	Parameter copy	Setting range: 0~2	Default: 0
--------	----------------	--------------------	------------

Set the function parameter copy. After the copy is completed, the parameter will automatically change to “0”.

**0: no operation**

**1: The inverter parameter value is transmitted to the keyboard and saved** The inverter F00 to F16 parameter group data is copied to the current operation keyboard and stored. At this point, the keyboard counts from 00 to 100 counts.

**2: The parameter value saved by the keyboard is transferred to the inverter** The data that has been copied in the current operating keyboard is downloaded to the inverter. At this point, the keyboard counts from 00 to 100 counts.

**Notes:**

- The single-line digital tube keyboard and the two-line digital tube keyboard memory are independent of each other, so the data saving and copying is subject to the currently operated keyboard.
- The parameter value saved by the keyboard cannot be transmitted to the inverter when the inverter is running or faulty or there is no parameter saved in the keyboard.
- When the inverter parameter value is transmitted to the keyboard and saved, if the keyboard cannot be copied after the keyboard is pulled out, the parameter copy operation needs to be performed again.
- When the parameter value saved on the keyboard is transmitted to the inverter, if the keyboard is pulled out, the previous part of the parameter modification will occur, and the latter part of the parameter is not modified, and the operation needs to be performed again.
- When the inverter parameter value is transmitted to the keyboard, the current running status of the inverter will not be maintained. When the parameter value saved by the keyboard is transmitted to the inverter, all the keys are invalid.
- Error in the parameter copy The keyboard displays E.COP (parameter copy exception). At this time, the copy is aborted and the parameter copy operation needs to be performed again. Press the PRG key to exit the E.COP display and return to the monitoring.
- When the software version is incompatible, it will prompt the error E.EDI, and the parameter value saved by the keyboard cannot be transmitted to the inverter.

F04.06	Keyboard special function selection	Setting range: 0000~1111	Default: 0000
--------	-------------------------------------	--------------------------	---------------

**LED “0” digit: run command, stop/reset command**

- 0: External priority, when the external is valid, the built-in is invalid.
- 1: Built-in priority, when the built-in is valid, the external is invalid
- 2: Both internal and external are valid, the stop/reset command takes precedence; when both forward and reverse are active, the command is invalid.

**LED “00” digit: keyboard communication options**

- 0: Both internal and external keyboards are valid
- 1: Only the built-in keyboard is valid
- 2: Only external keyboard is valid



**LED “000” digit: LCD Keyboard Language Selection**

Set the LCD LCD keyboard display language, which is only effective when using the LCD LCD keyboard.

0: Chinese LCD LCD keyboard display content language is Chinese.

1: English LCD LCD keyboard display content language is English.

**LED “0000” digit: Reserved**

F04.0 7	Double-line keyboard selections	REV/JOG	Setting range: 0-1	Factory set: 0
------------	---------------------------------	---------	--------------------	----------------

**Used to select the function of REV/JOG key****0: REV**

While keyboard control, press this button, inverter reverse run. Key REV/JOG not light.

**1: JOG**

While keyboard control, press this button, inverter JOG. Key REV/JOG light.

F04.0 8	STOP key function range	Setting range: 0~2	Factory set: 1
------------	-------------------------	--------------------	----------------

**0: non keypad control is invalid** While under non keypad control mode, the stop key in the keypad can not be used to stop.

**1: non keypad control stop by stop mode** While under non keypad control mode, the stop key in the keypad can be used as STOP key to stop.

It can be used as a stop button, and the stop mode is [F01.10] setting mode.

**2: non keypad control free stop** While under non keypad control mode, the stop key in the keypad can be used as STOP key to free stop.

It can be used as a stop button, the stop mode is free stop.

**Note: While valid to terminal order or communication order, inverter is in stop lock state after press STOP key under terminal control or RS485 control. If inverter needs to restart, stop order needs to be given by selected order channel to unlock stop state firstly.**

F04.0 9	UP/DOWN key modification selections	Setting range: 0000-0212	Factory set: 0011
------------	-------------------------------------	--------------------------	-------------------

**LED “0” digit: keyboard UN/DOWN key modify selection**

0: Invalid UP/DOWN key can not modify parameters.

1: Modify frequency setting by key board numbers (F0.08) UP/DOWN key can modify parameters [F0.08].

2: Modify PID given setting by key board numbers (F11.01) UP/DOWN key can modify parameters [F11.01].

3: Used to adjust the [F04.10] setting parameter [Fxx.yy] The keyboard up and down keys can quickly modify the setting value of the parameter [Fxx.yy].

**LED “00” digit: keyboard UP/DOWN key store selection**

0: No save after power down

1: Save after power down

It is used to select whether save the parameter modified by UP/DOWN key while power cut.

**LED “000” digit: operation limit**

- 0: Operation stop for adjusting
- 1: Adjusting only in operation, stop for holding
- 2: Adjusting in operation, stop for clearing

**LED “0000” digit: reserved**

F04.10	Keyboard up and down keys to quickly modify the parameter number setting Custom shortcut modification parameters	LED “00” digit: yy setting in Fxx.yy LED “000” and “0000”digits: xx setting in Fxx.yy For example: "0008" means F00.08 For example: "0009" means F00.09 For example: "1101" means F11.01	Factory set: 0008
F04.11- F04.13	Reserved		

Keyboard up and down keys quickly modify the parameter number setting:

**LED “00” digit: used to specify the parameter number 00~99**

**LED “000” digit: used to specify parameter group number 00~15**

F04.1 4	Keyboard display parameter 1	LED one digit ten: yy setting in monitoring code Cxx.yy LED hundred thousand digits: xx setting in monitoring code Cxx.yy For example: set "0000" to indicate that the monitoring code C00.00	Factory default: 0000
F04.1 5	Keyboard display parameter 2	Same as above	Factory default: 0001
F04.1 6	Keyboard display parameter 3	Same as above	Factory default: 0002
F04.1 7	Keyboard display parameter 4	Same as above	Factory default: 0011

Keyboard display parameters: used to set the contents of the single-line keyboard and double-line keyboard display parameters.

If F04.14 is set to 0000, the keyboard displays C00.00 given frequency.

Set to :0004 The display parameter is C00.04 (output voltage)

Set to :0011 and the display parameter is C00.11 (bus voltage)

Set to :0200 The display parameter is C02.00 (PID feedback)

Set to :0300 The display parameter is C02.00 (this power-on running time)

The single-line keyboard switches the keyboard display parameters 1-4 in sequence by long pressing the “SET” button (the two-line keyboard can be pressed through the “” button). Each time the button is pressed, one item is

skipped and cycles between display parameters 1-4.

After the display content is switched, there is no power-off and memory function. After power-on, the content of “Display Parameter 1” is displayed by default.

Access ‘C’ parameter group by pressing ‘PRG’ for more than 2s; check the current state of VFD

### C00-Basic Parameter Monitor Group

Function code	Function name	Unit and definition	Address
C00.00	Given frequency	0.01Hz	0x2100
C00.01	Output frequency	0.01Hz	0x2101
C00.02	Output current	0.1A	0x2102
C00.03	Input voltage	0.1V	0x2103
C00.04	Output voltage	0.1V	0x2104
C00.05	Machine speed	1RPM	0x2105
C00.06	Given torque	0.1%	0x2106
C00.07	Output torque	0.1%	0x2107
C00.08	PID given value	0.1%	0x2108
C00.09	PID feedback value	0.1%	0x2109
C00.10	Output power	0.1%	0x210A
C00.11	Bus voltage	0.1V	0x210B
C00.12	Module temperature 1	0.1°C	0x210C
C00.13	Module temperature 2	0.1°C	0x210D
C00.14	Input terminal X on state	See input terminal diagram	0x210E
C00.15	Output terminal Y on state	See output terminal diagram	0x210F
C00.16	Analog AI1 input value	0.001V/0.001mA	0x2110
C00.17	Analog AI2 input value	0.001V/0.001mA	0x2111
C00.18	Reserved		0x2112
C00.19	Pulse input value of PUL port	0.001kHz	0x2113
C00.20	Analog output AO1	0.01V/0.01mA/0.01kHz	0x2114
C00.21	Analog output AO2(extend)	0.01V/0.01mA/0.01kHz	0x2115
C00.22	Counting value of counter		0x2116
C00.23	Running time after power on	0.1 hour	0x2117
C00.24	Local accumulative running time	hour	0x2118
C00.25	VFD power level	kW	0x2119
C00.26	VFD rated voltage	V	0x211A
C00.27	VFD rated current	A	0x211B

C00.28	Software version		0x211C
C00.29	PG feedback frequency	0.01Hz	0x211D
C00.30	Counted time of timer	sec/min/hour	0x211E
C00.31	PID output value	0.00%	0x211F
C00.32	Software sub-version		0x2120
C00.33	Encoder angle	0.1°	0x2121
C00.34	Encoder deviation accumulative	1	0x2122
C00.35	Encoder Z signal pulse count	1	0x2123
C00.36	Fault pre alarm code	1	0x2124
C00.37	Total power consumption (low bit)	1°	0x2125
C00.38	Total power consumption (high bit)	10000°	0x2126
C00.39	Power factor angle	1°	0x2127

### C01-Malfunction Diagnosis Monitor Group

Press the PRG button for 2 seconds or more to enter the “C00” parameter group and press the up button to enter the “C01” parameter group. Check the current status of the drive.

Function code	Function name	Unit and definition	Addresses
C01.00	Malfunction types	See fault code table	0x2200
C01.01	Malfunction diagnosis information	See fault code table	0x2201
C01.02	Malfunction running frequency	0.00~Max frequency	0x2202
C01.03	Malfunction output Voltage	0~1500V	0x2203
C01.04	Malfunction out Current	0.1~1000.0A	0x2204
C01.05	Malfunction Bus Voltage	0~3000V	0x2205
C01.06	Malfunction module temperature	0~100°C	0x2206
C01.07	Malfunction machine state	<b>LED “0” digit: Running direction</b> 0: FWD 1: REV <b>LED “00” digit: Running status</b> 0: Stop 1: ACC 2: DEC 3: Constant speed <b>LED “000” and “0000” digit : Reserved</b>	0x2207
C01.08	Malfunction input terminal status	See input terminal chart	0x2208
C01.09	Malfunction output terminal status	See output terminal chart	0x2209
C01.10	The last malfunction types	Please see malfunction code table	0x220A
C01.11	The first diagnosis information	Please see malfunction code table	0x220B
C01.12	The last malfunction running frequency	0.00~Maxfrequency	0x220C
C01.13	The last malfunction output voltage	0~1500V	0x220D
C01.14	The last malfunction output current	0.1~2000.0A	0x220E
C01.15	The last malfunction bus voltage	0~3000V	0x220F
C01.16	The last malfunction module temperature	0~100°C	0x2210
C01.17	The last malfunction machine state	<b>LED “0” digit: Running direction</b> 0: FWD 1: REV <b>LED “00” digit: Running status</b> 0: Stop 1: Constant speed 2: ACC 3: DEC	0x2211

		<b>LED “000” and “0000” digit :</b>	
		<b>Reserved</b>	
C01.18	The last malfunction input terminal state	See input terminal chart	0x2212
C01.19	The last malfunction output terminal state	See output terminal chart	0x2213
C01.20	The first two malfunction types	Please see malfunction information code table	0x2214
C01.21	The first two diagnosis information		0x2215
C01.22	The first three malfunction types		0x2216
C01.23	The first three diagnosis information		0x2217

F04.18	Keyboard display parameter 5	Same as above	Factory set: 0002
F04.19	Keyboard display parameter 6	Same as above	Factory set: 0004
F04.20	Keyboard display parameter 7	Same as above	Factory set: 001
F04.21	Keyboard display parameter 8	Same as above	Factory set: 0012

It is valid only when the keyboard is double-lined, and is used to display the parameter selection on the second line of the keyboard. The two-line keyboard switches between the display parameters 5-8 of the second line of the keyboard by the " " key.

For details, see the parameters [F04.14~F04.17].

F04.22	Keyboard display selections	Setting range: 0000-1111	Factory set: 0000
--------	-----------------------------	--------------------------	-------------------

#### LED “0” digit: output frequency selection

0: Aim frequency Display the aim frequency of current control motor

1: Actual frequency Display the output frequency of inverter

#### LED“00” digit: Reserved

**LED“000” digit: Power display dimension** To correct the output frequency of C-10.Can select the unit of the power

0: Power display ratio (%) Display the ratio of output power,100% corresponds with the rated motor power.

1: Power display Kilowatt (KW) Display the actual power

#### LED“0000” digit: reserved

F04.2 3	Monitor display selection	<p><b>LED “0” digit: self-tuning display monitoring parameters</b> 0: Invalid 1: Valid</p> <p><b>LED “00” digit: C05 group display selection</b> 0-1: VF mode related parameters 2: VC mode related parameters</p> <p><b>LED “000” digit: C00.40~C00.69 display selection</b> 0: Do not display 1: Display</p>	Factory default: 0000
------------	---------------------------	--	-----------------------

F04.2 4	Rotate speed display coefficient	Setting range: 0.0-500.0%	Factory set: 100.0%
------------	----------------------------------	---------------------------	---------------------

It sets the display coefficient of keyboard monitor item “machine speed”. 100% is corresponding to motor rated speed.

F04.2 5	Power display coefficient	Setting range: 0.0-500.0%	Factory set: 100.0%
------------	---------------------------	---------------------------	---------------------

This parameter sets the display coefficient ratio of the keyboard monitor item “output power”; for example, when the output power is 10% of the rated motor, when F04.25 is set to 100.0%, C00.10 shows 10.0%; when 50.0% is set, C00.10 show 5.0%.

F04.2 6	Alarm selection 1	Setting range: 0000~0001	Factory set: 0
------------	-------------------	--------------------------	----------------

**LED “0” digit: E.EEP fault (EEPROM store fault)**

- 0: Alarm and free stop
- 1: Alarm and continue operation

**LED “00” digit: reserved**

**LED “000” digit: reserved**

**LED“0000” digit: reserved**

F04.2 7	Reserved		
------------	----------	--	--

F04.2 8	Fan control	Setting range: 0-2	Factory default: 1
------------	-------------	--------------------	--------------------

**Select fan run mode:**

- 0: Fan run after electrify** No matter temperature of module is high or not, fan runs when inverter power on.
- 1: Fan stop related to temperature** Work when running. When inverter stops, fan runs when module temperature

is over 50 degree and stops 30 seconds after module temperature is lower than standard. When inverter runs, fan runs after 1s.

**2: Fan stop when machine stop, run related to temperature** When inverter runs, fan runs when module temperature is over 50 degree and stops 30seconds after module temperature is lower than standard. When inverter stops, fan stops after 30s.

**Note: This function can prolong fan life.**

F04.2 9	Dynamic braking enabled	Setting range: 0~1	Factory default: 0
------------	----------------------------	--------------------	--------------------

#### Used for the motor dynamic braking enabled

**0: OFF** Inverter doesn't dynamic braking to control the motor, no matter the bus voltage.

**1: Turn on the energy brake and turn off the overvoltage suppression.** When the bus voltage exceeds the energy consumption braking action voltage, the inverter performs dynamic braking control on the motor, and the overvoltage suppression function is turned off at this time.

**2: Enable energy braking and overvoltage suppression at the same time.** When the bus voltage exceeds the energy consumption braking action voltage, the inverter performs dynamic braking control on the motor and turns on the overvoltage suppression function.

F04.3 0	Dynamic braking operation voltage	Setting range: 115.0-140.0%	Factory default: 120.0%
------------	--------------------------------------	-----------------------------	-------------------------

#### Dynamic braking operation voltage:

Inverter dynamic braking begins when DC bus voltage rises and exceeds **[F04.30]**. It is only valid for inverter with inner braking parts. Inverters under AC200-T3-018G have build in braking parts. AC200-S2-3R7G and inverters under than that with 220V input have built-in braking parts. All inverters do not have braking resistance. If need dynamic braking, please use optional resistance.

**Note: When use the dynamic braking function, please turn off the vervoltage suppression function, otherwise overvoltage suppression is possible to suppress the rise of the bus voltage, thus the brake operation point can't be reached.**

F04.3 1	Reserved		
------------	----------	--	--

F04.3 2	PWM Carrier frequency	Setting range: 0.7-16.0kHz	Factory default: model set
------------	-----------------------	----------------------------	----------------------------

It is used to set IGBT frequency. Please set this parameter when adjusting electromagnetic noise and reducing leakage current. This feature is mainly used to improve noise and vibration during operation of the inverter. At higher carrier frequency of the current wave, the motor noise would be small. It is suitable for locations that need mute environment when run in high carrier frequency, but at the same time the main parts switch loss and the heat are heavy while the efficiency would be reduced. In the meantime, radio disturbance is heavy. And the other problem is that capacitance leak current would increase, and if there is leak protection, there may be mistake action or over current. When run in low carrier frequency, the case will be totally different.



Different motors would have different carrier frequency responses. The best carrier frequency comes with adjustment based on actual case. The bigger the capacity, the smaller the carrier frequency should be.

The Company reserves the right to limit maximum carrier frequency.

Carrier frequency	Motor noise	Electric disturbance	Radiator temperature
low	big	Small	low
↓	↓	↓	↓
high	small	big	high

**Note:** We advice ratio of carrier frequency to max frequency not lower than 36. If work under low frequency long time, we advice reduce carrier frequency to reduce the dead area time impact.

**Cautions:** when carrier frequency is higher than the factory default, the rated power would reduce 5% every time when carrier frequency adds 1 KHz.

F04.33	PWM control mode	Setting range: 0000-1111	Factory default: 1111
--------	------------------	--------------------------	--------------------------

#### **LED “0” digit: carrier temperature associated settings**

0: associated module temperature is invalid

1: associated module temperature is valid

When module temperature is too high, the frequency inverter reduces carrier frequency automatically, which can reduce switch loss and avoid frequent alarm for over heat.

#### **LED “00” digit: associated settings of carrier output frequency**

0: associated frequency output temperature is invalid

1: associated frequency output temperature is valid

When carrier frequency is related to frequency output, it can automatic adjust carrier frequency according to frequency output, which can improve the low frequency performance and high frequency mute effect.

#### **LED “000” digit: random PWM valid**

0: banned: Noise frequency is fixed.

1: valid: This mode allows the inverter output voltage harmonic spectrum evenly distributes over a wide frequency range, which can effectively suppress electrical noise and mechanical vibration.

#### **LED “0000” digit: PWM modulation mode** select PWM mode

0: Only use the three-phase modulation

1: Switch automatically between two phase and three phase modulation

## 6.6 F5: Motor Parameters

F05.0 0	Motor selection	Setting range: 0~1	Factory set: 0
------------	-----------------	--------------------	----------------

**Motor selection:** Only read the parameter, indicating the current motor type. Decided by [F0.00] motor control mode.

**0: Asynchronous motor (AM)**

**1: Synchronous motor (PM)**

F05.0 1	Motor poles	Setting range: 2-98	Factory set: 4
------------	-------------	---------------------	----------------

Set the poles of the motor. Set it according to nameplate.

F05.0 2	Motor rated power	Setting range: 0.1-1000.0kW	Factory set: model set
------------	-------------------	-----------------------------	------------------------

Set it according to nameplate based on unit of 0.1kW. While motor rated power setting is changed, inverter will automatic adjust [**F05.03-F05.11**] to default. If self-tuning, [**F05.07-F05.11**] will automatic change according to the result of self study. If need high accuracy control, It must self study after right [**F05.01-F05.06**] setting.

F05.0 3	Motor rated frequency	Setting range: 0.01Hz-max frequency	Factory set: model set
------------	-----------------------	-------------------------------------	------------------------

Set it according to nameplate.

F05.0 4	Motor rated speed	Setting range: 1-65000rpm	Factory set: model set
------------	-------------------	---------------------------	------------------------

Set it according to nameplate.

F05.0 5	Motor rated voltage	Setting range: 1-1500V	Factory set: model set
------------	---------------------	------------------------	------------------------

Set it according to nameplate.

F05.0 6	Motor rated current	Setting range: 0.1-3000.0A	Factory set: model set
------------	---------------------	----------------------------	------------------------

Set it according to nameplate.

F05.0 7	Motor no-load current	Setting range: 0.01-650.00A	Factory set: model set
F05.0 8	Motor stator resistance	Setting range: 0.01-50.00%	Factory set: model set
F05.0 9	Motor rotor resistance	Setting range: 0.01~50.00%	Factory set: model set
F05.1 0	Motor stator&rotor inductance	Setting range:0.01~50.00%	Factory set: model set
F05.1 1	Motor stator&rotor mutual inductance	Setting range: 0.1-2000.0%	Factory set: model set

Asynchronous motor model parameters.[F05.07~F05.11 ]will adjust automatically while set [F05.20]parameter self-tuning.No self-tuning if the accurate motor parameter is known, and then input the parameters manually.

F05.1 2	PMSM stator resistance	Setting range: 0.01-50.00%	Factory default: Model set
F05.1 3	PMSM d-axis inductance	Setting range: 0.01mH-400.00%	Factory default: Model set
F05.1 4	PMSM q-axis inductance	Setting range: 0.01mH-400.00%	Factory default: Model set
F05.1 5	PMSM back electromotive force	Setting range: 1V-1500V	Factory default: Model set

PMSM model parameters, of which the back electromotive force represents the voltage measured between lines when the motor rotor speed is set to the rated frequency speed; motor model parameters will automatically identify and modify in the motor parameter self-tuning. Wherein, **[F05.15]** will be recognized only in a rotating auto-tuning.

F05.1 6	PMSM encoder installation angle	Setting range: 0.0°-360.0°	Factory default: Model set
------------	---------------------------------	----------------------------	----------------------------

When synchronous machines are running VC with PG (F0.00 = 7), this parameter is required to detect the magnetic pole position of the rotor. This parameter can be automatically identified and modified during the rotating auto-tuning, and generally it does not need adjustment.

F05.17~F05.1 9	Reserved		
-------------------	----------	--	--

F05.2 0	Parameters self-adjustment selections	Setting range: 0-2	Factory set: 0
------------	---------------------------------------	--------------------	----------------

**0: No operation** Set as default without self study.

**1: Rotary self-tuning** Before self adjustment, [F05.01-F05.06] of asynchronous motor which is controlled must be set as right value. While self adjustment, firstly, asynchronous motor at static state, it automatic detects motor stator resistance, motor rotor resistance, motor stator&rotor inductance. Then the asynchronous motor at rotate state, it automatic detects motor no-load current, motor stator&rotor mutual inductance. All results will be auto wrote in the corresponding code and renewed while adjustment is over. After parameter setting, press FWD key to start self study, keyboard LED display “t-01”. Motor automatic stop while self adjustment is over. Inverter return to standby state.

**2: Static self-tuning** Before self adjustment, [F05.01-F05.06] of motor which is controlled must be set as right value. While self adjustment, motor at static state, it automatic detects motor stator resistance, motor rotor resistance, motor stator&rotor inductance. All results will be auto wrote in the corresponding code and renewed while adjustment is over. After parameter setting, press FWD key to start self study, keyboard LED display “t-02”. FWD indicator is off while self adjustment is over. Inverter return to standby state.

**Note: [F05.20] is automatic set as 0 after self adjustment.**

**Cautions:**

- Before setting [F05.20] to "1" for rotary self-tuning, the motor shaft should be removed from the load as much as possible, and the motor should be prohibited from carrying a heavy load for self-tuning of the rotation parameters. Otherwise, the inverter will report the learning failure. The lighter the learning load is, the better the learning accuracy will be. The asynchronous motor load is recommended not to exceed 30% of the rated load, and the synchronous motor is recommended not to exceed 20% of the rated load.
- In some occasions (such as when the motor cannot be disconnected from the load), it is not convenient to perform self-tuning in rotation type. For asynchronous motors, static learning can be used to learn the full parameters of the motor except the encoder parameters. If you run the closed-loop vector of the asynchronous motor, you need to manually input the encoder direction. For synchronous motors, the motor back EMF F05.15 should be set after the static learning is completed. If the control mode selects the closed loop vector, whether it is static learning or dynamic learning, the synchronous motor will rotate at a lower frequency for several weeks to learn the coding. Angle parameter.
- Since the motor parameters are displayed in the form of standard values, it is not recommended to manually input the motor parameters. In most cases, static learning can be run to run the open-loop vector. Under the control of vf, learning the motor parameters will further optimize the automatic torque boost and slip. Compensation function.
- Before starting self-tuning, make sure that the motor is in a stopped state, otherwise self-tuning cannot be performed normally.
- When [F05.20] is set to "1", if overvoltage occurs during the self-tuning process and the overcurrent fault occurs, the acceleration/deceleration time can be extended appropriately [F00.14, F00.15].
- If the inverter self-tuning is unsuccessful, report E.TE1 failure.

F05.2	Synchronous machine poles searching	Setting	range:	Factory	default:
1	function	0000~0012		0010	

**LED “0” digit: closed-loop vector**

0: OFF

1: ON

2: On, only operate firstly when electrify

**LED “00” digit: open-loop vector**

0: OFF

1: ON

2: ON, only operate firstly when electrify

While synchronous motor control is valid, the initial position of the motor rotor can be obtained when starting by the poles searching function. Under the closed-loop VC control, if the motor coder has not self-tuning the initial position, then the start initial position can be obtained by this function. Under open-loop control, obtaining the initial position guarantees the motor has a big force and no REV running while starting.

For synchronous closed-loop control using ABZ coder, the motor poles is unknown before detecting Z pulse. Hence, it is suggested to turn on the poles searching function to guarantee the stable start process and no REV running.

F05.22~F05.29	Reserved
---------------	----------

F05.30	Speed feedback or encoder type	Setting range: 0000-1111	Factory default: 0000
--------	--------------------------------	--------------------------	-----------------------

**LED “0” digit: encoder type** set encoder type according to the encoders actually selected.

0: Normal ABZ encoder

1: Rotary encoder

**LED “00” digit: encoder direction** When motor speed direction and encoder speed direction is inconsistent, switch direction by setting the parameter.

0: same direction;

1: opposite direction

**LED “000” digit: disconnection detection** when the break detection is turned on, the inverter would report encoder failure and stop when encoder disconnection is found.

0: OFF

1: ON

**LED “0000” digit: Z pulse correction enabled**

0: OFF

1: ON

F05.31	ABZ encoder lines	Setting range: 0-10000	Factory default: 1024
--------	-------------------	------------------------	-----------------------

**ABZ encoder lines:** used to set output pulse of speed feedback sensor every cycle; please set correctly according to the sensor specification.

F05.3 2	PG line-break detection time	Setting range: 0.100-60.000s	Factory default: 2.000s
------------	------------------------------	------------------------------	-------------------------

**PG line-break detection time:** used to confirm sensor disconnection delay time when the sensor break detection setting is valid; set 0sec as the off function of line-break detection.

F05.3 3	Rotary encoder poles	Setting range: 2-128	Factory default: 2
------------	----------------------	----------------------	--------------------

**Rotary encoder poles:** Set according to actual selection of rotary encoder, usually 2-pole resolver

F05.3 4	Encoder transmission ratio numerator	Setting range: 1~32767	Factory default:1
F05.3 5	Encoder transmission ratio denominator	Setting range: 1~32767	Factory default:1

If the motor encoder is not installed in the motor shaft, it could obtain the motor speed and position indirectly through the transmission setting to achieve closed-loop VC function. The premise is that the motor shaft and encoder is rigid connection. While under synchronous motor controls, the encoder lines converted to motor shaft could not be much less.

The gear ratio setting range should be controlled within the range of 100~0.01, otherwise the inverter will report an abnormal PG parameter error.

F05.3 6	First-order filter of encoder speed inspection	Setting range: 0.0-100.0ms	Factory default: 1.0ms
------------	--	----------------------------	------------------------

Promote the filter time properly if the motor encoder feedback noise is too big, but prolonging the filtering time will decrease system response performance. In some occasions with higher requirements on response performance, if the filter time is too long, it will lead to system oscillation.

F05.39	PG feedback monitoring selection	<b>LED “0” digit: C00.29 monitor</b> <b>PG feedback speed.</b> 0: invalid, 1: valid	Factory default: 0
--------	----------------------------------	---	--------------------

## 6.7 F6: VC Control Parameter

F06.0 0	ASR proportional gain 1	Setting range: 0.01-100.00	Factory set: 10.00
F06.0 1	ASR integral time 1	Setting range: 0.000-6.000	Factory set: 0.500
F06.0 2	ASR filter time1	Setting range: 0.0-0.100.0ms	Factory set: 0.0ms
F06.0 3	ASR switch frequency 1	Setting range: 0.00-max frequency	Factory set: 0.00Hz
F06.0 4	ASR proportional gain 2	Setting range: 0.01-100.00	Factory set: 10.00
F06.0 5	ASR integral time 2	Setting range: 0.000-6.000	Factory set: 0.500
F06.0 6	ASR filter time 2	Setting range: 0.0-0.100.0ms	Factory set: 0.0ms
F06.0 7	ASR switch frequency 2	Setting range: 0.00-max frequency	Factory set: 5.00Hz

**ASR proportional gain and ASR integral time adjustment:** System response will be quicker by increase proportional gain. But if proportional gain is too big, there is surge easily. System response will be quicker by decreasing integral time. But if integral time is too short, there is surge easily. Usually, adjust proportional gain firstly, then adjust integral time.

**Note: If ASR proportional gain is too big and ASR integral time is too small, over voltage maybe caused while system start to high speed quickly (without extra braking resistance or braking unit). It is caused by reborn energy feedback and can be avoided by adjust ASR proportional gain bigger and ASR integral time smaller.**

### ASR proportional gain and ASR integral time adjustment at high/low speed:

Set ASR switch frequency [F06.03] and [F06.07] while it has quick response requirement for load at high/low speed. Usually increase proportional gain and decrease integral time to improve response at low frequency running. Usually adjust as this: Set right [F06.03] and [F06.07]. The first group of ASR parameter is valid while output frequency is under switch frequency 1 [F06.04]. The second group of ASR parameter is valid while output frequency is between switch frequency 1 [F06.03] and switch frequency 2 [F06.07]. Parameter linearly transits from switch frequency 1 [F06.03] to switch frequency 2 [F06.07] pro rate. Adjust ASR proportional gain 2[F06.04] and ASR integral time2 [F06.05] at low speed to ensure no surge and good response. Adjust ASR proportional gain 1 [F06.00] and ASR integral time 1[F06.01] at high speed to ensure no surge and good response. While the switch frequency1 [F06.03] is set 0, just use the first group ASR parameter.

F06.08	Electric torque limit	Setting range: 0.0~400.0%	Factory default: 180.0%
F06.09	Power generation torque limit	Setting range: 0.0~400.0%	Factory default: 180.0%

Set the upper limit of the torque output of the motor. The percentage is relative to the rated torque of the motor. It is valid under the asynchronous machine, synchronous machine open loop and closed loop vector. The motor torque output is also limited by the inverter output current limit [F10.01] and output power [F06.27]. For details, please refer to the function code description.

F06.10	Current loop D-axis proportional gain	Setting range: 0.001~4.000	Factory default: 1.000
F06.11	Current loop D-axis integral gain	Setting range: 0.001~4.000	Factory default: 1.000
F06.12	Current loop Q-axis proportional gain	Setting range: 0.001~4.000	Factory default: 1.000
F06.13	Current loop Q-axis integral gain	Setting range: 0.001~4.000	Factory default: 1.000

Set the PI parameters of the current loop when the asynchronous machine and synchronous machine vector control. When vector control occurs, if speed, current oscillation, and instability occur, the gain can be appropriately reduced to achieve stability; at the same time, increasing the gain helps to improve the dynamic response of the motor.

F06.1 5	Vector control motor slip compensation	Setting range: 0.0-250.0%	Factory default: 100.0%
F06.1 6	Reserved		

The PM VC control is valid. While under open-loop VC control, the slip compensation coefficient is used to adjust the motor speed stabilization accuracy. When the motor speed is lower than the set value with load, the motor speed is increased, and vice versa. It is better to set within the range of 60~160%.

F06.18	position compensation control	Setting range:0~1	Factory default: 0
F06.19	Compensation gain	Setting range:0.0~250.0%	Factory default: 10.0%
F06.20	Compensation limit	Setting range:0.0~100.0%	Factory default: 0.1%
F06.21	Compensation effective range	Setting range:0.0~100.0%	Factory default: 10.0%

Position compensation on can accurately obtain the position of motor start

F06.2 2	Over excitation braking gain	Setting range: 0.0-500.0%	Factory default: 100.0%
F06.2 3	Over excitation braking amplitude limit	Setting range: 0.0~250.0%	Factory default: 100.0%

AM VC control is valid,.The over excitation function can realize much more quickly DEC control and no over-voltage. The higher over excitation is, the faster response is. Braking limit corresponds to motor rated excitation,the greater limit is, the better braking effect is. However, the excessive limit will make the motor temperature rise when DEC.Only in good heat radiation condition ,this value can be properly increased .



F06.2 4	Vector control energy saving function	Setting range: 0~1	Factory default: 0
F06.2 5	Energy saving control gain	Setting range: 0.0~80.0%	Factory default: 50.0%
F06.2 6	Energy saving control low-pass filter	Setting range: 0.000~6.000s	Factory default: 0.010s

**Vector control energy saving function:****0: off****1: On, only valid at constant speed****2: On, valid at constant speed, acceleration and deceleration**

The asynchronous machine vector control is effective. When the energy-saving operation is performed, the output current is automatically reduced by analyzing the torque output, so that the heating loss of the motor is reduced to achieve the energy-saving effect.

F06.2 7	Motor constant power area power limit	Setting range: 0.0-250%	Factory set: 150.0%
------------	---------------------------------------	-------------------------	---------------------

While under VC control, it can control the output power of motor shaft. If the motor runs at low/middle speed, the motor output power is lower. At this time, the motor torque is limited by the motor/generator torque [F06.08~F06.09]. If the motor runs at high speed or above the rated speed, the output power is limited by [F06.27], and the output torque decrease inversely with the speed.

F06.2 8	Motor weak magnetic current upper limit	Setting range: 0.0-250.0%	Factory set: 60.0%
F06.2 9	Motor weak magnetic feed forward gain	Setting range: 0.0-200.0%	Factory set: 0.0%
F06.3 0	Motor weak magnetic gain	Setting range: 0.0-500.0%	Factory set: 100.0%

While under AM/PM VC control, if the motor speed is above the rated speed, or the bus voltage is lower and the running speed is near the rated speed, the inverter need to control the motor under the weak magnetic control, so that the motor can track speed setting.

[F06.28] is set to the upper limit of demagnetizing current, and be valid to PM motor. Compared to the motor rated current, too big weak magnetic current will make the motor demagnetize irreversibly. Mostly weak magnetic current can guarantee that the motor does not demagnetize irreversibly within motor rated current; [F06.29 ~ F06.30] set the weak magnetic control parameters. When there is instability phenomenon in the weak magnetic process, adjust this parameters group for debugging.

F06.31	Reserved
--------	----------

F06.3 2	MTPA gain	Setting range: 0.0-400.0%	Factory default: 100.0%
F06.3 3	MTPA filter time	Setting range: 0.0-100.0ms	Factory default: 1.0ms

MTPA function is optimizing the PMSM excitation strategies to achieve Max motor output / motor current; when the permanent magnet motor D, Q-axis inductance difference is large, adjust **[F06.32]** can significantly change the motor current under same load; adjust **[F06.33]** can improve the stability of the motor running.

F06.34	Reserved
--------	----------

F06.3 5	Low frequency pull in current	Setting range: 0.0~100.0%	Factory default: 10.0%
F06.3 6	High frequency pull in current	Setting range: 0.0~100.0%	Factory default: 10.0%
F06.3 7	Frequency of current pulled in	Setting range: 0.0~100.0%	Factory default: 10.0%

PM open-loop VC control is valid. The current is relative to motor rated current and frequency is relative to the max output frequency. The pulled in current is mainly used to promote the load ability in low frequency. The pull-in current frequency **[F06.37]** as high frequency distinguish threshold, if low frequency load is larger, the pull-in the current should be promote properly, but too large current will affect the efficiency of the motor. The actual use should be set up according to the load situation.

## 6.8 F7: Torque Control Parameters

F07.0 0	Torque/Speed control	Setting range: 0-1	Factory default: 0
------------	----------------------	--------------------	--------------------

**0: Speed control.** With speed as the control quantity, the inverter meets the system usage requirements with speed output control to meet the speed requirements of the system.

**1: Torque control.** This option is valid under vector control. Torque output control, with the motor torque output as the main control target, adjust the output torque to achieve control, mainly used in tension equipment and torque requirements equipment.

**Note:**

- **The basic parameter group F00.03-F00.07, F00.10-F00.16 is only valid in speed mode.**
- **In torque mode, the frequency control is detailed in F07.10-F07.13**

F07.0 1	Torque given channel selection	Setting range: 0-7	Factory default: 0
------------	--------------------------------	--------------------	--------------------

Using a relative value for torque setting; 100.0% corresponds to motor rated torque; Setting range from 0% to 200.0%, indicating that the inverter torque is 2 times the maximum rated torque.

**0: Keyboard digital reference** When this option is selected, the torque value is given by the function code [F07.02].

**1: reserved**

**2: AI1** is set by the AI1 terminal voltage or current analog input, and the voltage or current input can be selected by the switch on the control board.

**3: AI2** is set by the AI2 terminal voltage or current analog input, and the voltage or current input can be selected by the switch on the control board.

**4: Reserved**

**5: PUL** is set by the high-speed pulse input from the PUL terminal. The torque setting correspondence needs to adjust the PUL related parameters.

**6: RS485 communication setting** Set by RS485 serial communication, communication address 0x3005/0x2005.

**7: Option card**

F07.0 2	Torque keyboard number setting	Setting range: 0-100.0%	Factory default: 0.0%
------------	--------------------------------	-------------------------	-----------------------

When the function code [F07.01] = 0, the torque setting point is given by the function code [F07.02].

F07.0 3	Torque input lower limit	Setting range: 0.00-100.00%	Factory default: 0.00%
F07.0 4	Lower limit corresponding setting	Setting range: -200.00-200.00%	Factory default: 0.00%

F07.0 5	Torque input upper limit	Setting range: 0.00-100.00%	Factory default: 100.00%
F07.0 6	Upper limit corresponding setting	Setting range: -200.00-200.00%	Factory default: 100.00%
F07.0 7	Given first-order filter time	Setting range: 0.000-6.000s	Factory default: 0.100s

The value of torque given channel is linearized by [F07.03~F07.06] to get the torque given value.

**Given first-order filter time:** Filter the torque given value to make the given torque change smoothly.

F07.0 8	Output torque upper limit	Setting range: 0-200.0%	Factory default: 150.0%
F07.0 9	Output torque lower limit	Setting range: 0-200.0%	Factory default: 0%

**Output torque upper limit:** Used to set the upper limit of output torque during torque control; upper limit actual output torque = rated torque \* F07.08

**Output torque lower limit:** Used to set the output torque lower limit when torque control; lower limit actual output torque = rated torque \* F07.09

F07.1 0	Torque control FWD speed limit selecting	Setting range: 0-7	Factory default: 0
------------	--	--------------------	--------------------

**This parameter is the frequency control channel in torque mode** and is used for the forward maximum operating frequency limit of the inverter.

When the inverter torque is controlled, if the load torque is less than the motor output torque, the motor speed will continue to rise. To prevent accidents such as flying in the mechanical system, the maximum motor speed during torque control must be limited.

**0: Keyboard digital reference** Is given by function code [F07.12].

**1: reserved**

**2: AI1 × F07.12** is set by AI1 terminal voltage or current analog input, voltage or current input can be selected by switch on the control board

**3: AI2 × F07.12** is set by AI2 terminal voltage or current analog input, voltage or current input can be selected by switch on the control board

**4: Reserved**

**5: PUL × F07.12** High-speed pulse input from the PUL terminal.

**6: RS485 communication reference × F07.12** is set by RS485 serial communication, communication address 0x3006/0x2006.

**7: Optional card × F07.12**

**Note:**

- **100.0% for each channel corresponds to the maximum frequency F00.09.**
- **The forward direction is the direction in which the inverter runs when the given torque of the inverter is 0% to 200% (regardless of F00.16).**
- **The reverse direction is the direction in which the inverter runs when the given torque of the inverter is 0% to -200% (regardless of F00.16).**

F07.1 1	Torque control REV speed limit selecting	Setting range: 0-7	Factory default: 0
------------	--	--------------------	--------------------

**0: Keyboard number given:** by the function code [F07.13] given.

**1: Reserved**

**2: AI1 × F07.13:** set by the AI1 terminal analog voltage input.

**3: AI2 × F07.13:** set by the AI terminal analog voltage or current input, voltage or current input can be selected via the control panel switch.

**4: Reserved**

**5: PUL × F07.13:** set by PUL terminal high-speed pulse.

**6:RS485 communication given×F07.13:** set by the RS485 serial communication; communication address 0x3007 / 0x2007.

**7: Option card x F07.13**

**Note: 100% corresponds to the max output frequency.**

F07.1 2	Torque control FWD Max speed limit selecting	Set range: 0.0-100.0%	Factory default: 100.0%
F07.1 3	Torque control REV Max speed limit selecting	Set range: 0.0-100.0%	Factory default: 100.0%

When the function code [F07.10], [F07.11] is set to 0, the Max speed limit would be set by [F07.12], [F07.13].And protect in case of initial debugging torque function default 100.0% as the seldom speed setting.

## 6.9 F8: V/F Control Parameters

F08.0 0	V/F curve selection	Setting range:0-11	Factory set: 0
------------	---------------------	--------------------	----------------

**V/F curve selection:** used to select the V/F curve types to meet different load requirements.

0: Beeline

1-9: 1.1-1.9 respectively VF power curve, as shown below;

10: VF square curve;

11: custom VF curve; see [F08.01-F08.10];

VF default linear curve for most common situations; multi-idempotent curve and square VF curve are generally used for VF fans or pumps to reduce the high-frequency current to achieve energy savings.

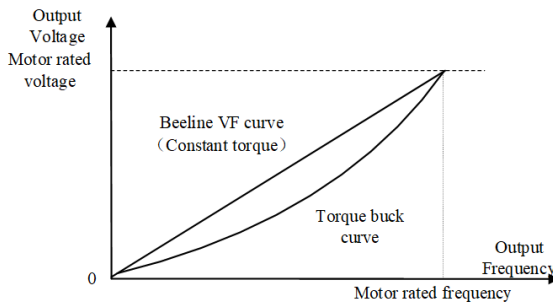

F08.0 1	Self-setting voltage V1	Setting range: 0.0-100.0%	Factory set: 3.0%
F08.0 2	Self-setting frequency F1	Setting range: 0.00-max frequency	Factory set: 1.00Hz
F08.0 3	Self-setting voltage V2	Setting range: 0.0-100.0%	Factory set: 208.0%
F08.0 4	Self-setting frequency F2	Setting range: 0.00-max frequency	Factory set: 10.00Hz
F08.0 5	Self-setting voltage V3	Setting range: 0.0-100.0%	Factory set: 55.0%
F08.0 6	Self-setting frequency F3	Setting range: 0.00-max frequency	Factory set: 25.00Hz
F08.0 7	Self-setting voltage V4	Setting range: 0.0-100.0%	Factory set: 708.0%
F08.0 8	Self-setting frequency F4	Setting range: 0.00-max frequency	Factory set: 37.50Hz
F08.0 9	Self-setting voltage V5	Setting range: 0.0-100.0%	Factory set: 100.0%

F08.1 0	Self-setting frequency	Setting range: 0.00-max frequency	Factory set: 50.00Hz
------------	------------------------	-----------------------------------	----------------------

Self-setting V/F curve:

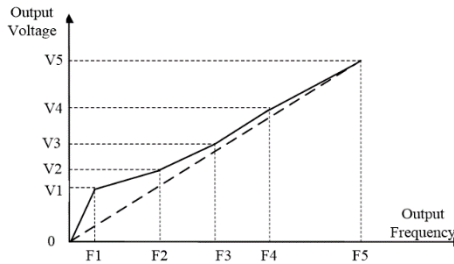

User sets the 1<sup>st</sup>/2<sup>nd</sup>/3<sup>rd</sup>/4<sup>th</sup>/5<sup>th</sup> voltage ratio of V/F curve corresponding to F1/F2/F3/F4/F5 frequency based on rated output voltage 100%. User sets the 1<sup>st</sup>/2<sup>nd</sup>/3<sup>rd</sup>/4<sup>th</sup>/5<sup>th</sup> frequency of V/F curve corresponding to V1/V2/V3/V4/V5. Must meet:  $0 \leq F1 \leq F2 \leq F3 \leq F4 \leq F5 \leq \text{max frequency}$ ,  $0 \leq V1 \leq V2 \leq V3 \leq V4 \leq V5 \leq 100.0\%$   
 V1, V2, V3, V4, V5 is based on motor rated voltage.

F08.1 1	Output voltage percentage	Setting range: 25.0-120.0%	Factory set: 100.0%
------------	---------------------------	----------------------------	---------------------

Output voltage adjustment coefficient adjusts output voltage of inverter to meet different V/F requirement.

F08.1 2	Torque boost	Setting range: 0.0-30.0%	Factory set: 0.0%
F08.1 3	Torque boost cut-off frequency	Setting range: 0.0-100.0%	Factory set: 100.0%

**Torque boost:**

Automatically torque boost while [F08.12] is set 0, and compensate the output voltage automatically according to the load. Fixed torque boost while [F08.12] is set other values. Improve low frequency torque trait by voltage compensation. Please set it rightly. If too high, motor maybe happens over excitation at low frequency running, over heat while long time, even over current protection or can not start normally.

**Note:**

- While [F08.00] is “1 custom v/F curve”, [F08.12] is invalid, and inverter will running with the custom

**V/F curve.**

- **The drive only runs on a custom V/F curve.**

**Torque boosts cut-off frequency:**

Set torque improves valid range. While output frequency is over this value, torque improving function stops. 100% is corresponding to motor rated frequency.

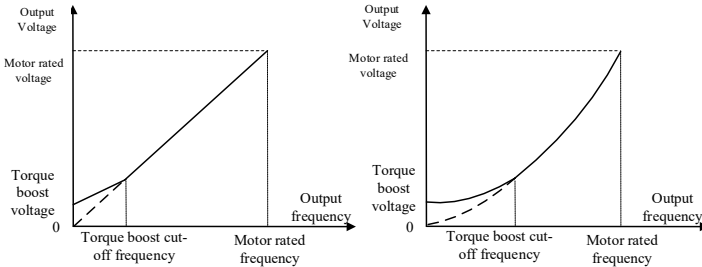

Torque lifting diagram

F08.1 4	slip compensation gain	Setting range:0.0-200.0%	Factory set:100.0%
F08.1 5	Slip compensation limit	Setting range:0.0-300.0%	Factory set:100.0%
F08.1 6	Slip compensation filter time	Setting range:0.000-6.000s	Factory set:0.200s

It makes inverter output frequency self adjust within a setting range according motor load change to compensate slip frequency to make motor keep constant speed. It effectively relieves the impact of load change to motor speed.

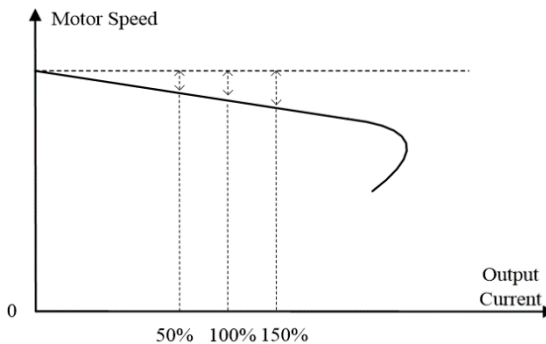

Slip compensation diagram

If it is used with the automatic torque boost function,the low frequency trait can be promoted obviously.100.0% slip frequency compensation corresponds to the motor rated slip; it may cause the motor speed exceeds setting value



when the compensation value is set too large .Hence, [F08.15] setting need to be limited.Slip compensation filter time is to filter the slip compensation to eliminate disturb signal. The longer filter time is, the stronger anti-disturb force is. The shorter filter time is, the weaker anti-disturb force is. But respond speed will be quicker.

**The slip compensation function needs to correctly input the motor nameplate parameters and learn the parameters to achieve the best results.**

F08.17	Surge suppression gain	Setting range: 0.0-900.0%	Factory set: 100.0%
--------	------------------------	---------------------------	---------------------

While the motor control mode F0.00=0 or 1,it is easily to appear motor current instability and motor speed oscillation phenomenon in medium and high power occasions , which is a combination of electrical and mechanical effects of low-frequency resonance. It is possible to suppress the low frequency resonance by adjusting the [F08.17], but excessive suppression gain may lead to additional stability problems.

F08.18	Reserved		
F08.19	Auto energy saving control	Setting range: 0-1	Factory set: 0
F08.20	Energy saving frequency lower limit	Setting range: 0.0-50.0Hz	Factory set: 15.00Hz
F08.21	Energy saving voltage lower limit	Setting range: 0.0-100.0%	Factory set: 50.0%
F08.22	Energy saving voltage regulation rate	Setting range: 0 ~ 0.200V/MS	Factory set:0.010V/MS
F08.23	Energy saving voltage recovery rate	Setting range: 0 ~ 0.200V/MS	Factory set:0.200V/MS

#### Auto energy save selection:

Under the condition of light load, the motor can adjust the output voltage automatically after entering the constant speed to promote the efficiency to save energy.

0: OFF

1: ON

#### Energy saving frequency lower limit:

When output frequency is lower than this value, auto energy save function will exit.

#### Energy saving voltage lower limit:

While automatically saving energy running, the lower limit of the voltage can reduce.100.0% is corresponding to the current output voltage corresponding to the output frequency without saving energy.

#### Energy saving voltage regulation rate:

The rate of voltage regulation during the process of energy saving.

**Energy saving voltage recovery rate:**

The rate of voltage recovery to the normal voltage while exit the energy saving process.

**Note: Enter energy saving only at constant speed running, hence this function is not suitable to be used in occasions where the given frequency changes frequently.**

F08.24~F08.3 4	Reserved
-------------------	----------

## 6.10 F10: Malfunction and Protection Parameters

F10.00	OC suppression function	Setting range: 0~1	Factory default: 0
F10.01	OC suppression point	Setting range: 0.0-300.0%	Factory default: 160.0%
F10.02	OC suppression gain	Setting range: 0.0-500.0%	Factory default: 100.0%

### OC suppression function:

The OC suppression function can monitor the real-time load current, and automatically limit it below the set of OC suppression point, to prevent the fault trip caused by excessive current. To some large inertia or sharp changing load, the function is especially valid.

### 0: Suppression valid

### 1: ACC/DEC valid, constant speed invalid

### OC suppression point:

Set current limit level (By stopping ACC/DEC or decreasing/ increasing output frequency to control the output current).

### OC suppression gain:

Adjust the response speed of OC suppression.

**Note: Using this function might prolong ACC/DEC time. During the process of inverter start/ stop, if in the case of high current, the output frequency will not ACC/DEC to the given frequency as expected, which shows that the limiting function. At that time, please reduce the load or adjust relevant parameters.**

F10.03	Current hardware protection settings	Setting range: 0000-0221	Factory set: 0001
--------	--------------------------------------	--------------------------	-------------------

### LED “0” digit: cycle-by-cycle current limit:

cycle-by-cycle current limit can limit current rise to a certain extent by hardware protection so that the current does not exceed the protection value of the inverter and avoid skipping flow fault shutdown.

0: Close

1: Open

### LED “00” digit: OC protection disturbing suppression

While this function is valid, invert will judge the E. OC alarm intelligently to eliminate the disturbance, and only make the alarm to the real fault signal. This function may delay the alarm time, and please use it cautiously.

0: Off

1: First grade disturbing suppression

2: Second grade disturbing suppression

### LED “000” digit: SC protection First grade disturbing suppression

While this function is valid, invert will judge the E. SC alarm intelligently to eliminate the disturbance, and only make the alarm to the real fault signal. This function may delay the alarm time, and please use it cautiously.

0: Off

- 1: First grade disturbing suppression
- 2: Second grade disturbing suppression

**LED “0000” digit: Reserved**

F10.04-F10.05	Reserved
---------------	----------

F10.0	Bus over voltage suppression	Setting range: 0000-0012	Factory set: 0012
6	protection		

**LED “0” digit: Over voltage suppression control**

- 0: Prohibited
- 1: Valid in DEC
- 2: Valid both in ACC/DEC

**Select whether DEC OV suppression is valid** :If this function is valid,when bus voltage reaches or exceeds [F10.07] when inverter DEC running, the inverter will slow down or stop DEC, thus ensuring there’s no OV protection due to high bus voltage.

**Select whether ACC OV suppression is valid** :If this function is valid,when bus voltage reaches or exceeds [F10.07] when inverter ACC running, the inverter will automatically adjust the operating frequency and suppress the bus voltage from increasing, thus ensuring there’s no OV protection due to high bus voltage. This function is special valid to eccentric load.

**LED “00” digit: Overexcitation control**

- 0: Off
- 1: On

**LED “000” digit: Reserved****LED “0000” digit: Reserved**

**Note: When using the energy consumption setting functions, please turn off or turn on the overvoltage suppression control according to the site conditions.**

F10.07	Bus over voltage suppression point	T3: 650-780 (default 750) T2/S2: 340-380 (default 365)	Factory default: Model set
F10.08	Bus over voltage suppression gain	Setting range: 0.0-500.0%	Factory default: 100.0%

When bus voltage reaches or exceeds [F10.07] when inverter running, the inverter will automatically adjust the operating frequency and suppress the bus voltage from increasing, thus ensuring there’s no OV protection due to high bus voltage. Adjusting [F10.08] can promote OV suppression effect; set [F10.08] = 0: cut-off OV suppression function and OV suppression is valid for any motor control mode.

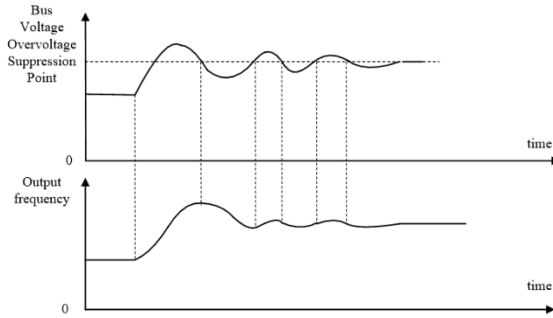

Overvoltage suppression diagram

F10.09	Bus under-voltage suppression function	Setting range: 0~1	Factory default: 0
F10.10	Bus under voltage suppression point	T3: 350-450 (default 430) T2/S2: 180-260 (default 240)	Factory default: Model set
F10.11	Bus under voltage suppression gain	Setting range: 0.0-500.0%	Factory default: 100.0%

When bus voltage reaches or lower than [F10.10] when inverter running, the inverter will automatically adjust the operating frequency and suppress the bus voltage from decreasing, thus ensuring there's no LV protection due to low bus voltage. Adjusting [F10.11] can promote LV suppression effect; set [F10.09] = 0: cut-off LV suppression function and LV suppression is valid for any motor control mode.

F10.12	Bus under-voltage protection point	T3: 300-400V(default 320) T2/S2: 160-240V(default 190)	Factory default: Model set
--------	------------------------------------	---	----------------------------

**Bus under-voltage protection point:** This parameter specifies the lower voltage allowed by bus voltage during operation, for some low power occasions, appropriate under-voltage protection level can be reduced to ensure the normal working of the inverter.

**Note:** When the grid voltage is too low, the motor output torque will decrease. For constant power load and

**constant torque load, low grid voltage will increase the frequency converter input and output current, thereby reducing the reliability of the inverter operation.**

F10.1 3	Input phase loss threshold	Setting range: 0.0% to 30.0%	Factory default: 10.0%
------------	----------------------------	---------------------------------	------------------------

**Input phase loss threshold:** When the input phase loss detection function is turned on, when the field voltage fluctuation is large, the threshold value can be appropriately increased without affecting the normal operation of the machine.

F10.1 4	Power-to-ground short-circuit detection	Setting range: 0000-0012	Factory default: 0011
------------	--	--------------------------	-----------------------

**LED “0” digit: short circuit to ground** When the motor connected to the inverter is short-circuited to ground, it will report the output phase loss fault E.SG.

- 0: off
- 1: Power-on detection
- 2: Test every run

**LED “00” digit: fan short circuit** When the inverter fan short circuit occurs when the fan is short-circuited (or 24V short circuit), the inverter will restart 2 times. Will report the output phase loss fault E.FSG,

- 0: off
- 1: open

**LED “000” digit: Reserved**

**LED “0000” digit: Reserved**

F10.1 5	Phase loss protection	Setting range: 0000-0021	Factory default: 0011
------------	-----------------------	--------------------------	-----------------------

**LED “0” digit: output phase protection:**

- 0: Close
- 1: Open

**LED “00” digit: input phase protection:**

- 0: Off
- 1: Open the alarm
- 2: Open the fault

**LED “000” digit: Reserved**

**LED “0000” digit: Reserved**

F10.16	Motor overload protection curve coefficient	Set range: 0.0-250.0%	Factory default: 100.0%
--------	--	-----------------------	----------------------------

Long term motor overload would produce serious heat, [F10.16] sets the coefficient of load motor overload protection or thermal protection; the motor overload protection and motor current curve was inverse, protection curve when F10.16 = 100.0% is shown as follows:

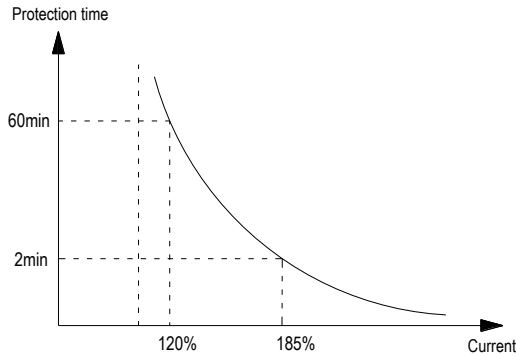

The current entering protection curve= (the real motor current / oL protection coefficient)x110%

So increasing [F10.16] can improve motor overload; overload pre alarm coefficient can be set by [F10.16], when the motor had reached the degree of overload factor [F10.16] setting, the inverter outputs alarm by terminal, for details please see Y terminal function.

**Note: When a inverter parallel with several motors in operation, th the thermal relay protection function will have no use, in order to effectively protect the motor, please install the thermal protection relay at the end of each motor.**

F10.17	Load pre alarm detection setting	Setting range: 0000~1414	Factory default: 0000
--------	----------------------------------	--------------------------	-----------------------

**LED “0” digit: Detection selection (protection 1)**

- 0: Not detected
- 1: Detected load is too large
- 2: Detected load is too large only at constant speed
- 3: Insufficient load detected
- 4: Insufficient load only at constant speed

**LED “00” digit: Alarm selection**

- 0: Alarm and continue operation
- 1: Fault protection and free stop

**LED “000” digit: Detection selection (protection 2)**

- 0: Not detected
- 1: Detected load is too large
- 2: Detected load is too large only at constant speed
- 3: Insufficient load detected
- 4: Insufficient load only at constant speed

**LED “0000” digit: Alarm selection**

0: Alarm and continue operation

1: Fault protection and free stop

F10.18	Load pre alarm detection level 1	Setting range: 0.0~200.0%	Factory default: 130.0%
F10.19	Load pre alarm detection time 1	Setting range: 0.0~60.0s	Factory default: 5.0s
F10.20	Load pre alarm detection level 2	Setting range: 0.0~200.0%	Factory default: 30.0%
F10.21	Load pre alarm detection time 2	Setting range: 0.0~60.0s	Factory default: 5.0s

In the VF control mode, the motor output current is used as the load warning judgment value, 100.0% corresponds to the rated motor current; in the vector control mode, the motor output torque is used as the load warning judgment value, 100.0% corresponds to the rated output torque of the motor, and the load warning judgment value is The detection time [F10.19/F10.21] is compared with the detection threshold [F10.18/F10.20], and the corresponding action is performed according to [F10.17]. The alarm can be output through the terminal output. See Y Terminal function for details..

#### Check out the selection (Protection 1):

##### 1: Detection load is too large

The running detection value is greater than [F10.18] load warning detection level 1 and the valid signal is output after [F10.19] load warning detection time 1;

##### 2: Excessive load detection only at constant speed

In the constant speed state, the detected value is greater than [F10.18] load warning detection level 1 and the valid signal is output after [F10.19] load warning detection time 1;

##### 3: Insufficient detection load

The running detection value is less than [F10.20] load warning detection level 2 and the valid signal is output after [F10.21] load warning detection time 2;

##### 4: Insufficient load detection only at constant speed

In the constant speed state, the detected value is less than [F10.20] load warning detection level 2 and the effective signal is output after [F10.21] load warning detection time 2;

Checkout selection (Protection 2): Same checkout selection (Protection 1)

F10.2 2	Reserved
------------	----------

F10.2 3	Protection action when speed slip is too large	Setting range: 0000-0012	Factory default: 0000
------------	--	--------------------------	-----------------------

LED “0” digit: Detection selection



0: Not detected

1: Detected at constant speed

2: Detecting

**LED “00” digit: Alarm selection**

0: Free stop and report fault

1: Alarm and continue operation

**LED “000” digit: Reserved**

**LED “0000” digit: Reserved**

F10.2 4	detection threshold when speed slip is too large	Set range: 0.0-60.0%	Factory default: 10.0%
F10.2 5	detection time when speed slip is too large	Set range:0.0-60.0s	Factory default: 2.0s

Under VC control,if the speed feedback value and speed setting bias are more than detection threshold [F10.24] during the detection time [F10.25], inverter judges that the detection bias is too large and operate according to [F10.23].Speed bias detection threshold 100% corresponds to max frequency..

F10.2 6	Rapid protection action	Setting range: 0000-0012	Factory default: 0000
------------	-------------------------	--------------------------	--------------------------

**LED “0” digit: Detection selection**

0: Not detected

1: Detected at constant speed

2: Detecting

**LED “00” digit: Alarm selection**

0: Free stop and report fault

1: Alarm and continue operation

**LED “000” digit: Reserved**

**LED “0000” digit: Reserved**

F10.27	Rapid detection threshold	Setting range: 0.0~150.0%	Factory default: 110.0%
F10.28	Rapid detection time	Setting range:0.000~2.000s	Factory default: 0.010s

Under VC control,if the speed feedback value is more than detection threshold [F10.27] during the detection time [F10.28], inverter judges that the speed abnormal and operate according to [F10.26].Speed bias detection threshold 100% corresponds to max frequency..

F10.2 9	Motor overheat protection selection (extended)	Setting range: 0000~0021	Factory default: 0000
------------	--	-----------------------------	--------------------------

**LED “0” digit: temperature detection type selection**

0: PT100,

1: KTY

**LED “00” digit: temperature detection action**

0: no detection

1: alarm and free parking

2: Warning and continue to run

**LED “000” digit: Reserved**

**Note: PT100 is preferentially selected by the DIP switch. When the DIP switch is dialed to KTY/PT100, the temperature detection type is set by F10.29.**

F10.3 0	Motor overheat protection threshold (extended)	Setting range: 0.0~200.0°C	Factory default: 100.0 °C
F10.3 1	Motor overheat warning threshold (extended)	0.0~200.0 °C (A.oH3 exceeded the threshold warning)	Factory default:90.0

When the motor temperature is greater than the overheat protection threshold, report the fault or warning according to F10.29 E.OH3, A.oH3

F10.3 5	Starting threshold of motor overload	Setting range: 100% ~ 130%	Factory default:110%
F10.3 6	Motor overload current coefficient	0.0~250.0	Factory default:100%

When the actual current is bigger than the value set by F10.35, the overload time will accumulate.

Motor overload multiple = calculated motor overload current / rated motor current

Calculated motor overload current = actual current \* F10.36 (motor overload current coefficient)

Overload schedule of key points of each level at 50Hz

Motor overload protection time (min)		(Calculated motor overload current / rated motor current ) ×100%		
		110%	150%	200%
Insulation class	F	75	16	3.5

It can be seen from the above data that the f10.36 coefficient affects the overload capacity of the motor. The smaller the setting, the stronger the overload capacity of the motor, and the larger the setting, the easier to report the overload fault of the motor.

F10.3 8	Malfunction auto-reset times	Setting range: 0-5	Factory default: 0
F10.3 9	Malfunction auto-reset interval	Setting range: 0.1-100.0s	Factory default:1.0s

**Malfunction auto-reset times:**

**0: Off** No automatic reset function; manual reset.

**1-5: On** 1-5 is the automatic reset times;

The inverter would fail or stop during operation due to load fluctuations, voltage fluctuations and other factors. At this time in order to ensure continuity of system operation, automatic resets of inverter for overload, over current, system abnormalities, over voltage, under voltage faults are allowed. The inverter would restart by speed tracking in the process of self recovery. If the inverter can't restart within the set times, stop output for fault protection; Fault recovery times can be set up to five times, after 10 minutes running the fault recovery times would be re-recorded and the times before is automatically cleared. Consecutive failures of restarting might cause harm, so the proposed fault recovery time is 1;

Output terminal can be selected to act or not act in automatic reset process. Details refer to **[F02.45-F02.47]**.

**Malfunction auto-reset interval:** It defines waiting time before resetting after fault.

**Note:**

- **Only valid for fault of OL, OC, system abnormal, under voltage. Not valid for other faults.**
- **Can't reset before dealing with malfunction.**

**Attention:** Please use this function carefully in occasions that can't start with load, or that needs alarm immediately when there's no output.

### 6.11 F11: PID Parameters

PID control is used for process control mode normal. For the aim of that the object which be controlled is stabilized as the PID given, it adjusts inverter output frequency to form passive feedback PID adjustment by series of proportional, integral, differential calculation by difference between the feedback of that be controlled and the inverter PID given.

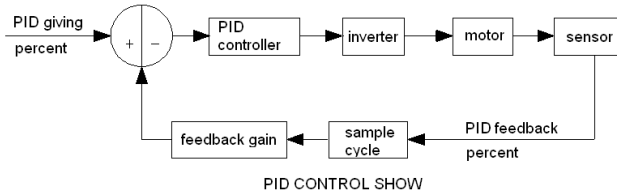

F11.0	PID give signal source	Setting range: 0-8	Factory set: 0
0			

Use to set the input channel of PID controller given signal.

- 0: Keyboard number given PID** Decided by [F11.01] setting.
- 1: Reversed**
- 2: AI1:** set by the AI1 terminal analog voltage input.
- 3: AI2:** set by the AI terminal analog voltage or current input.
- 4: Reversed**
- 5: PUL** set by PUL terminal high-speed pulse.
- 6: RS485 communication given:** set by the RS485 serial communication; communication address 0x3008 / 0x2008.
- 7: Option card:** set by option card. Details refer to option card specification.
- 8: Terminal selection** PID giving is selected by multifunction input terminal combine which is set by [F02.00-F02.06].
- 9: Communication given active current**

Terminal switch table:

Terminal 3	Terminal 2	Terminal 1	PID giving terminal switch selection
OFF	OFF	OFF	Keyboard number give PID
OFF	OFF	ON	Keyboard potentiometer
OFF	ON	OFF	Terminal AI1 voltage analog
OFF	ON	ON	Terminal AI analog
ON	OFF	OFF	Terminal AS current analog
ON	OFF	ON	Terminal PUL pulse signal

ON	ON	OFF	RS485 communication
ON	ON	ON	Optional card

Any doubt please see "FC" parameter group which is about multispeed time sequence.

F11.0 1	Keyboard number given/feedback	PID	Setting range: 0.00-100.0%	Factory set: 50.0%
------------	--------------------------------	-----	----------------------------	--------------------

This function is valid only when [F11.00]/[F11.03] is set as keyboard number given/feedback. After this parameter is changed, PID given in monitor object is modified automatically at the same time.

If [F11.09] LED "0" is set as 2, this value can be modified by UP/DW key. Whether save the modification is decided by [F04.09] LED "00" digit.

F11.0 2	PID given changing time	Setting range:0.00-60.00	Factory set:1.00s
------------	-------------------------	--------------------------	-------------------

#### PID given changing time:

the ratio of PID given changing time from 0.0% to 100.0% .While PID given changes,PID given changes in linear line by the given time to reduce the bad influence of given surge.

F11.0 3	PID feedback signal source	Setting range:0-9	Factory set:2
------------	----------------------------	-------------------	---------------

Set the input channel of the PID controller feedback signal.

**0: Keyboard digital PID feedback** The PID feedback channel is determined by the setting value of [F11.01].

**1: reserved**

**2: Voltage/current analog AI1 feedback** The PID feedback channel is the voltage/current analog AI1.

**3: Voltage/current analog AI2 feedback** The PID feedback channel is the voltage/current analog AI2.

**4: Reserved.**

**5: Terminal pulse PUL feedback** The PID feedback channel is the terminal pulse PUL.

**6: RS485 communication feedback** The PID feedback channel is RS485 communication, and the communication address is 0x3009/0x2009.

**7: Optional card** The PID feedback channel is an optional card. For details, refer to the optional card manual.

**8: Terminal selection** The PID feedback channel is selected by the combination of multi-function input terminals. The multi-function input terminal is set by [F02.00~F02.09].

**9: Communication given active current**

**Terminal switch table:**

Terminal 3	Terminal 2	Terminal 1	PID giving terminal switch selection
OFF	OFF	OFF	Keyboard number give PID

OFF	OFF	ON	Keyboard potentiometer
OFF	ON	OFF	Terminal AII voltage analog
OFF	ON	ON	Terminal AI analog
ON	OFF	OFF	Terminal AS current analog
ON	OFF	ON	Terminal PUL pulse signal
ON	ON	OFF	RS485 communication
ON	ON	ON	Optional card

Any doubt please see "FC" parameter group which is about multispeed time sequence.

**Note: The PID signal source and PID controller feedback signal source cannot be set to the same channel, otherwise the PID will not work normally.**

F11.0 4	Feedback signal filter time	Setting range: 0.000-6.000s	Factory set: 0.010s
F11.0 5	Feedback signal gain	Setting range: 0.00-10.00	Factory set: 1.00
F11.0 6	Given and feedback range	Setting range: 0-100.0	Factory set: 100.0

#### Feedback signal filter time:

Filter the feedback signal to eliminate to the disturb. The longer filter time is,the stronger anti-disturb force is,but the slower feedback response is.

#### Feedback signal gain:

It is used to linearize the feedback input signal.

#### Given and feedback range:

PID given and feedback don't have the unit to adjust the PID given (C-08) and PID feedback display(C-09).PID given and feedback 100.0% corresponds with the given and feedback range[F11.06].For example,[F11.06]is set 80.0,if the PID given 50.0%, and then PID given display C-08 is 40.0.

F11.0 7	PID control selection	Setting range: 0000-1111	Factory set: 0000
------------	-----------------------	--------------------------	-------------------

#### LED "0" digit: feedback trait selection

**0: Positive trait.** It is suitable for occasions where PID feedback is bigger than PID given and requires reduce output frequency PID to balance PID. Such as constant pressure water supply, gas supply, take-up tension control.

**1: Negative trait.** It is suitable for occasions where PID feedback is bigger than PID given and requires raise output frequency PID to balance PID. Such as constant temperature control, pay-off tension control.

**LED "00" digit: Reserved**

**LED "000" digit: Reserved**

**LED "0000" digit: Differential adjustment properties**

**0: Differential of deviation**

**1: Differential of feedback**

F11.0 8	PID preset output	Setting range: 0.00-100.0%	Factory set: 100.0%
F11.0 9	PID preset output running time	Setting range: 0.0-6500.0s	Factory set: 0.0s

While it defines as PID start running, frequency ACC to PID pre-set output [F11.08] according to ACC time 1. After setting [F11.09] time, it runs as PID closed loop trait.

**Note: When PID is used for frequency source given, [F0.03 = 8] preset outputs 100.0% corresponding maximum output frequency.**

F11.1 0	PID control deviation limit	Setting range: 0.00-100.0%	Factory default: 0.0%
------------	-----------------------------	----------------------------	-----------------------

The max deviation allowed by PID feedback to PID given. When feedback is in this range, PID adjustment stops. Output does not change; the reasonable use of the feature helps coordinate the contradiction between system output accuracy and stability.

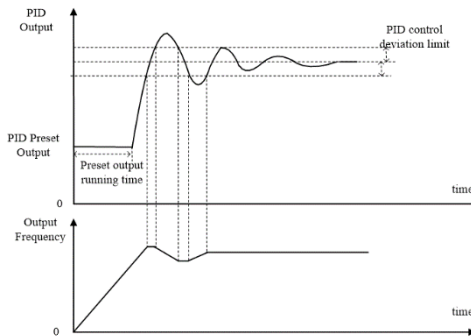

PID adjustment diagram

F11.1 1	Proportion gain: P1	Setting range: 0.000-9.999	Factory set: 0.100
F11.1 2	Integral time: I1	Setting range: 0.0-600.0s	Factory set: 1.0s
F11.1 3	Differential coefficient : D1	Setting range: 0.000-6.000s	Factory set: 0.000s
F11.1 4	Proportion gain: P2	Setting range: 0.000-9.999	Factory set: 0.100

F11.1 5	Integral time: I2	Setting range: 0.0-600.0s	Factory set: 1.0s
F11.1 6	Differential coefficient : D2	Setting range: 0.000-6.000s	Factory set: 0.000s

The parameter value controlled by PID should be set according to the actual characteristics of the system. PID parameters group 1 (F11.11~F11.13) and PID parameters group 2(F11.14~F11.16) ,are selected by the switch conditions [F11.17] set.

**Proportion gain P:**

It decides impact of P act to bias. Response is quicker while gain is bigger. But there will be surge while it is too big.

**Integral time I:**

It decides the size of effect of I act. The impact is stronger while the I is bigger.

**Differential coefficient D:**

Decide the impact of change rate of PIN controller to bias or feedback signal. According to the change trend, to adjust to suppression the change of feedback signal.

F11.1 7	PID parameter switching condition	Setting range: 0~2	Factory set:0
F11.1 8	Low value of switching deviation	Setting range: 0.0-100.0%	Factory set: 20.0%
F11.1 9	High value of switching deviation	Setting range: 0.0-100.0%	Factory set: 80.0%

In some occasions, just one group of PID adjusting parameters can ont meet the requirement of the process ,hence different PID parameters group need to be adopted in different occasions.

**PID parameter switching condition:**

**0: Not switch** PID parameters select the group 1 (F11.11~F11.13)

**1: Use DI terminal to switch** Multi function terminal selection is set 23 (PID parameters switch).While this terminal is invalid, select PID group 1 (F11.11~F11.13); while this terminal is valid,select group 2(F11.14~F11.16).

**2: Switch according to deviation** While the deviation absolute value of PID given and feedback is less than [F11.18], select group 1;while the deviation absolute value of PID given and feedback is more than [F11.19], select group 2;while the deviation absolute value of PID given and feedback is between [F11.18] and [F11.19], select the linear interpolation value of the 2 groups,which is as follows;



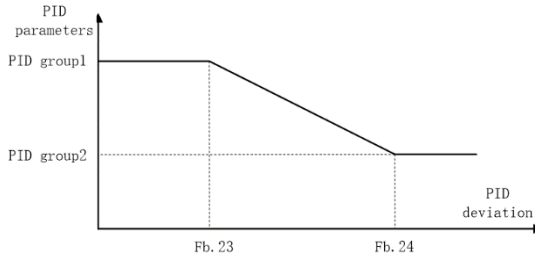

Switching the PID parameters according to the deviation

F11.20	Reserved
--------	----------

F11.2 1	Differential limit	Setting range: 0.0-100.0%	Factory set: 5.0%
------------	--------------------	---------------------------	-------------------

[F11.21] differential limit is used to set PID differential output range. In PID controller, the differential effect is sensitive, and easy to make the system oscillation. Usually, limit the PID differential range within a small scale.

F11.2 2	PID output upper limit	Setting range: 0.0-100.0%	Factory set: 100.0%
F11.2 3	PID output lower limit	Setting range: -100.0%-F11.22	Factory set: 0.0%
F11.2 4	PID output filter time	Setting range: 0.000-6.000s	Factory set: 0.0s

[F11.22 ] is used to set the PID output upper limit;[F11.23] sets the PID output lower limit.

[F11.24] PID output filter time used to filter the PID output.It will weak the surge caused by PID output result, and decrease the closed-loop system response performance.

F11.2 5	Detection time while feedback wire break	Setting range: 0.0-120.0s	Factory set: 1.0s
F11.2 6	Act selections while feedback wire break	Setting range: 0-3	Factory set: 0
F11.2 7	Wire break alarm upper limit	Setting range: 0.0-100.0%	Factory set: 100.0%
F11.2 8	Wire break alarm lowest limit	Setting range: 0.0-100.0%	Factory set: 0.0%

While PID given frequency and inverter is running, if feedback signal which is bigger the [F11.27] or smaller than [F11.28] is detected out and keeps for [F11.25] delay time, it is considered as sensor wire break.

**Feedback wire-break action selections**

**0: Go on PID operation without alarm:** no wire-break detection when invalid

**1: Stop and alarm malfunction:** When the inverter detects a sensor break, immediately block output, motor free stop and report E.PID fault.

**2: Go on PID operation and output alarm signal:** When the inverter detects a sensor break, still run by the PID regulation, but the keyboard displays E.PID fault and flashes.

**3: Run the current frequency and output alarm signal:** When the inverter detects a sensor break, maintain constant output frequency before the fault, but the keyboard displays E.PID fault and flashes.

#### Wire break alarm upper limit:

Set the upper limit of PID sensor wire break detection. When feedback signal is over alarm upper limit for time [F11.25], it is considered as sensor wire break.

#### Wire break alarm lower limit:

Set the lower limit of PID sensor wire break detection. When feedback signal is under alarm upper limit for time [F11.25], it is considered as sensor wire break.

F11.2 9	Constant pressure water supply sleep selection	0: Invalid 1: Valid	Factory default: 0
F11.3 0	Sleep frequency	0.00Hz ~ max frequency F0.09	Default: 10.00
F11.3 1	Sleep delay	0.0~3600.0 s	Default: 60.0
F11.3 2	Wake-up deviation	0.0~50.0%	Default: 5.0
F11.3 3	Wake-up delay	0.0~60.0S	Default: 1.0

#### Constant pressure water supply sleep selection:

**0: Invalid** no sleep detection

**1: Valid** for sleep detection

#### Sleep into the judgment:

When the constant pressure water supply sleep function is valid, when the PID adjustment output frequency is lower than the set [F11.30] sleep frequency, it will enter the sleep state after the [F11.31] sleep delay (ie, the output will be blocked after deceleration to zero frequency).

#### Sleep wakeup judgment:

When the PID feedback characteristic is positive:

The PID reference (C00.08) minus the wake-up deviation (F11.32) is compared with the PID feedback (C00.09). If it continues to be greater than the wake-up delay [F11.33], it exits the sleep state and enters the normal operating status.

When the PID feedback characteristic is inverse characteristic:

The PID reference (C00.08) plus the wake-up deviation (F11.32) is compared with the PID feedback (C00.09). If

it continues to be greater than the wake-up delay [F11.33, exit the sleep state and enter the normal running state.

## 6.12 F12: Multi-step, PLC Function and Swing Frequency Parameters

F12.00	Step 1	Setting range: 0.00-max frequency	Factory set: 10.00Hz
F12.01	Step 2	Setting range: 0.00-max frequency	Factory set: 20.00 Hz
F12.02	Step 3	Setting range: 0.00-max frequency	Factory set: 30.00 Hz
F12.03	Step 4	Setting range: 0.00-max frequency	Factory set: 40.00 Hz
F12.04	Step 5	Setting range: 0.00-max frequency	Factory set: 50.00 Hz
F12.05	Step 6	Setting range: 0.00-max frequency	Factory set: 40.00 Hz
F12.06	Step 7	Setting range: 0.00-max frequency	Factory set: 30.00 Hz
F12.07	Step 8	Setting range: 0.00-max frequency	Factory set: 20.00 Hz
F12.08	Step 9	Setting range: 0.00-max frequency	Factory set: 10.00 Hz
F12.09	Step 10	Setting range: 0.00-max frequency	Factory set: 20.00 Hz
F12.10	Step 11	Setting range: 0.00-max frequency	Factory set: 30.00 Hz
F12.11	Step 12	Setting range: 0.00-max frequency	Factory set: 40.00 Hz
F12.12	Step 13	Setting range: 0.00-max frequency	Factory set: 50.00 Hz
F12.13	Step 14	Setting range: 0.00-max frequency	Factory set: 40.00 Hz
F12.14	Step 15	Setting range: 0.00-max frequency	Factory set: 30.00 Hz

It sets run frequency of 15 steps in PLC and multistep control.

Multi steps control has priority only after JOG. While multi steps control, 4 multifunction input terminals are needed to set as control terminals. Set details refer to **[F02.00-F02.06]**.

Inverter is running at which step is decides by the ON/OFF state of 4 control terminal and COM. Run and direction is controlled by run signal and direction given by **[F0.02]**. ACC/DEC time default is ACC/DEC time 1 **[F0.14]**, **[F0.15]**. Or select ACC/DEC time by ACC/DEC time selection terminal set by **[F02.00-F02.06]**.

Multi-speed terminal 4	Multi-speed terminal 3	Multi-speed terminal 2	Multi-speed terminal 1	terminal speed
OFF	OFF	OFF	ON	1X <b>[F12.00]</b>
OFF	OFF	ON	OFF	2X <b>[F12.01]</b>
OFF	OFF	ON	ON	3X <b>[F12.02]</b>
OFF	ON	OFF	OFF	4X <b>[F12.03]</b>
OFF	ON	OFF	ON	5X <b>[F12.04]</b>
OFF	ON	ON	OFF	6X <b>[F12.05]</b>
OFF	ON	ON	ON	7X <b>[F12.06]</b>
ON	OFF	OFF	OFF	8X <b>[F12.07]</b>
ON	OFF	OFF	ON	9X <b>[F12.08]</b>
ON	OFF	ON	OFF	10X <b>[F12.09]</b>
ON	OFF	ON	ON	11X <b>[F12.10]</b>
ON	ON	OFF	OFF	12X <b>[F12.11]</b>
ON	ON	OFF	ON	13X <b>[F12.12]</b>
ON	ON	ON	OFF	14X <b>[F12.13]</b>
ON	ON	ON	ON	15X <b>[F12.14]</b>

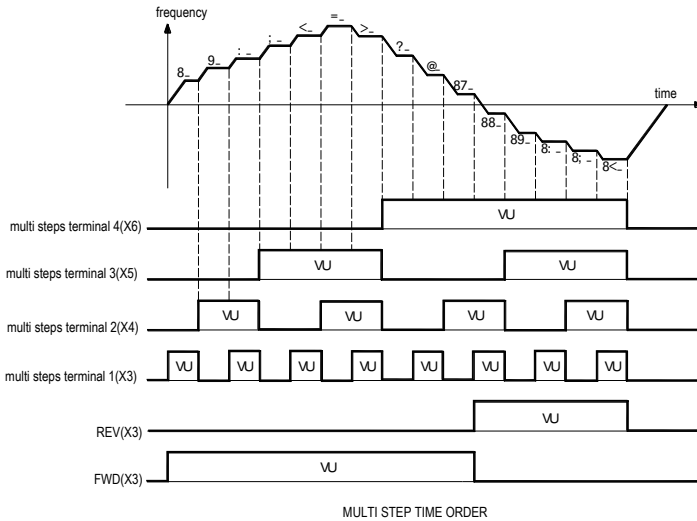
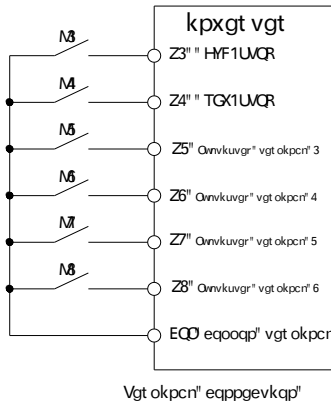

F12.15	PLC run mode selections	Setting range: 0000-2212	Factory set: 0000
--------	-------------------------	--------------------------	-------------------

Select PLC running mode while program given.

**LED “0” digit: cycle mode**

**0: Stop after single cycle** While receiving order, inverter run from the first step, time unit is set by [F12.15] LED “00” digit. Running time is set by [F12.16-F12.30]. Running direction and ACC/DEC time is selected by [F12.31-F12.45]. Turn to next step while run time is over, run time, direction, ACC/DEC time of every step can be set separately. Inverter output 0 Hz while finished 15 steps running. If one step running time is 0, it will skip this step.

**1: Continuous cycles** Inverter not stop and runs at the latest speed while finished 15 steps running. Time unit is

set by [F12.15] LED “00” digit. Run time is set by [F12.16-F12.30]. Run direction and ACC/DEC time is selected by [F12.31-F12.45].

**2: Keep final value after single cycle** Inverter back to 1<sup>st</sup> step while finished 15 steps running. Time unit is set by [F12.15] LED “00” digit. Run time is set by [F12.16-F12.30]. Run direction and ACC/DEC time is selected by [F12.31-F12.45].

**Note:** PLC ACC/DEC time is set by [F12.31-F12.45] LED “00”, and not be affected by terminal selection.

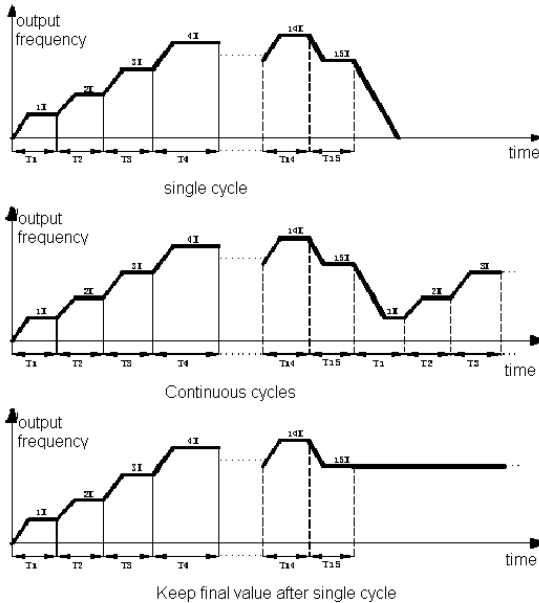

#### LED“00”digit: Time unit

- 0: second
- 1: minute
- 2: hour

#### LED“000”digit: Power down save mode

- 0: no save
- 1: save

This parameter is defined as when the selection process is running, the inverter power whether to store the current state of the running program (running stages, the remaining time of this stage, deceleration and running direction , etc.). If you choose power down storage, the “000”digit of [F12.15] defines the way power is restored of the next running. To ensure sustainable state of inverter after power recovery, the parameter should be set as “1”.

#### LED“0000”digit: Start-up mode

- 0: Restart from the 1st step**
- 1: Restart from the step where stop**
- 2: Restart from the time when stop**

Set restart mode while stop for some reasons (stop, fault, power off and so on).

Choosing 0: Restart from the 1st step

Choosing 1: Restart from the step when stop

Choosing 2: Continue from the time when stop

**Note: Output frequency is limited by upper/lowest limitation. While frequency is lower than lowest limitation, it runs as [F0.13] lowest limitation mode.**

F12.1 6	PLC 1st step running time	Setting range: 0.0-6500.0(s/m/h)	Factory set: 10.0
F12.1 7	PLC 2nd step running time	Setting range: 0.0-6500.0(s/m/h)	Factory set: 10.0
F12.1 8	PLC 3rd step running time	Setting range: 0.0-6500.0(s/m/h)	Factory set: 10.0
F12.1 9	PLC 4th step running time	Setting range: 0.0-6500.0(s/m/h)	Factory set: 10.0
F12.2 0	PLC 5th step running time	Setting range: 0.0-6500.0(s/m/h)	Factory set: 10.0
F12.2 1	PLC 6th step running time	Setting range: 0.0-6500.0(s/m/h)	Factory set: 10.0
F12.2 2	PLC 7th step running time	Setting range: 0.0-6500.0(s/m/h)	Factory set: 10.0
F12.2 3	PLC 8th step running time	Setting range: 0.0-6500.0(s/m/h)	Factory set: 10.0
F12.2 4	PLC 9th step running time	Setting range: 0.0-6500.0(s/m/h)	Factory set: 10.0
F12.2 5	PLC 10th step running time	Setting range: 0.0-6500.0(s/m/h)	Factory set: 10.0
F12.2 6	PLC 11th step running time	Setting range: 0.0-6500.0(s/m/h)	Factory set: 10.0
F12.2 7	PLC 12th step running time	Setting range: 0.0-6500.0(s/m/h)	Factory set: 10.0
F12.2 8	PLC 13th step running time	Setting range: 0.0-6500.0(s/m/h)	Factory set: 10.0
F12.2 9	PLC 14th step running time	Setting range: 0.0-6500.0(s/m/h)	Factory set: 10.0
F12.3 0	PLC 15th step running time	Setting range: 0.0-6500.0(s/m/h)	Factory set: 10.0

Set running time of every 15 steps. Time unit is decided by [F12.15] LED "00" digit setting.

F12.3 1	PLC 1st step direction and ADD/DEC time	Setting range: 0000-0031	Factory set: 0000
------------	---	-----------------------------	-------------------

F12.3 2	PLC 2nd step direction and ADD/DEC time	Factory set: 0000
F12.3 3	PLC 3rd step direction and ADD/DEC time	Factory set: 0000
F12.3 4	PLC 4th step direction and ADD/DEC time	Factory set: 0000
F12.3 5	PLC 5th step direction and ADD/DEC time	Factory set: 0000
F12.3 6	PLC 6th step direction and ADD/DEC time	Factory set: 0000
F12.3 7	PLC 7th step direction and ADD/DEC time	Factory set: 0000
F12.3 8	PLC 8th step direction and ADD/DEC time	Factory set: 0000
F12.3 9	PLC 9th step direction and ADD/DEC time	Factory set: 0000
F12.4 0	PLC 10th step direction and ADD/DEC time	Factory set: 0000
F12.4 1	PLC 11th step direction and ADD/DEC time	Factory set: 0000
F12.4 2	PLC 12th step direction and ADD/DEC time	Factory set: 0000
F12.4 3	PLC 13th step direction and ADD/DEC time	Factory set: 0000
F12.4 4	PLC 14th step direction and ADD/DEC time	Factory set: 0000
F12.4 5	PLC 15th step direction and ADD/DEC time	Factory set: 0000

Set running direction and ACC/DEC time of every 15 step while program running.

**LED “0” digit: this step run direction**

**0: FWD**

**1: REV**

If [F0.16] LED “00” digit is 1 only the FWD command is allowed, and if setting is REV, inverter runs as 0.00Hz.

**LED “00” digit: ACC/DEC time in this step**

0: ACC/DEC time 1

1: ACC/DEC time 2

2: ACC/DEC time 3

4: ACC/DEC time 4

**LED “000” digit: reserved**

**LED “0000” digit: reserved**



F12.46-F12.48	Reserved
---------------	----------

F12.49	Swing frequency control	Setting range: 0-1	Factory default: 0
F12.50	Swing amplitude control	Setting range: 0-1	Factory default: 0
F12.51	Reserved		
F12.52	Swing frequency amplitude	Setting range: 0.0-100.0%	Factory default: 10.0%
F12.53	Jump frequency amplitude	Setting range: 0.0-50.0%	Factory default: 10.0%
F12.54	Swing frequency rising time	Setting range: 0.00-650.00s	Factory default: 5.00s
F12.55	Swing frequency falling time	Setting range: 0.00-650.00s	Factory default: 5.00s

The inverter changes output frequency periodically with a predetermined ACC/DEC time when swing frequency runs. This feature is especially useful in the textile industry system in which the speed changes according to the diameter of bobbin.

Swing center frequency comes from given frequency of main and auxiliary channel or the set frequency in multi-speed or PLC running; swing frequency would be automatically canceled in jog and closed-loop running. When PLC and swing frequency run simultaneously, switching between the PLC segment and swing frequency would fail; swing frequency begins after transiting from PLC deceleration phase to PLC set frequency; press PLC stage ACC/DEC time to decelerate when stop.

While using the swing frequency([F12.49] is valid),inverter ACC to swing center frequency according to ACC/DEC time, and then cycle run according to the swing frequency amplitude [F12.52], startup frequency [F12.53], swing frequency rising time [F12.54] and swing frequency falling time [F12.55] until the stop command by deceleration time.

### Swing frequency control

This parameter defines whether use the swing frequency function

0: invalid

1: valid

### Swing amplitude control

0: Relative to center frequency: variable,swing amplitude AW changes with the center frequency, the rate of change, see [F12.52] definition.

1: Relative to max frequency:fixed, Amplitude AW is determined by the maximum frequency and [F12.52]

**Swing frequency amplitude:** This parameter defines the frequency amplitude when in swing frequency control.

**Variable Swing:**  $AW = \text{center frequency} \times [F12.52]$

**Fixed Swing:**  $AW = \text{maximum operating frequency} [F0.09] \times [F12.52]$

**Jump swing frequency amplitude:** used to set the jump frequency while set the swing frequency running.

**Start up frequency=** Swing frequency amplitude  $AW \times [F12.53]$

**Swing frequency rising time:** used to set the ACC time of swing frequency.

**Swing frequency falling time:** used to set the DEC time of swing frequency.

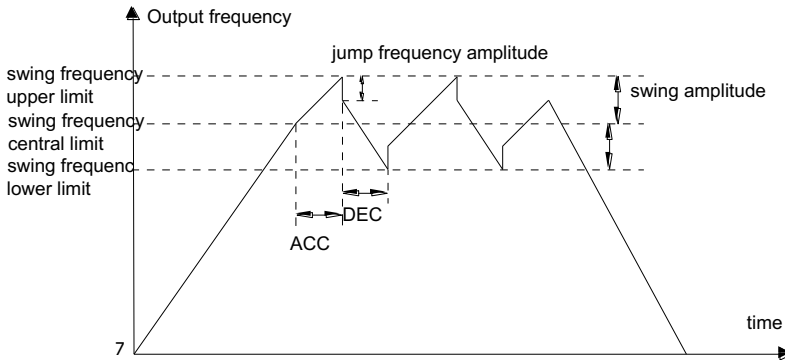

Swing frequency control diagram

## 6.13 F13: Communication Control Function Parameters

F13.0 0	Main-slave machine	Setting range: 0000-011	Factory set: 0000
------------	--------------------	-------------------------	-------------------

Choose inverter as main machine or slave machine when Modbus communication or CAN communication. Details for Modbus, refer to Appendix 2:Modbus communication protocol.

### LED “0” digit: modbus communication main and slave selection

**0: Slave machine** Inverter is slave machine. Communication address is decided by [F13.01]. Inverter receives order from main machine and decides whether to reply or not when writing operation according to [F13.08] setting. Reply delay time is set by [F13.05].

**1: Main machine** Inverter, as main machine, sends data to communication network by broadcast orders. All slave machines accept orders from main machine. The data sending of main machine is set by [F13.09].

### LED “00” digit: Can communication master-slave selection

**0: slave**

**1: host**

LED “000” digit: reserved

LED “0000” digit: reserved

**Note: When the inverter is used as the host network, all network slaves must also be Flextronics inverters to be properly networked. Broadcast data is sent over a custom free protocol.**

F13.0 1	485 communication address	Setting range: 1-247	Factory set: 1
------------	---------------------------	----------------------	----------------

It set communication address while inverter is Modbus communication slave machine. If inverter is main machine, this parameter is no meaning. 0 is broadcast address.

F13.0 2	Communication baud rate selections	Setting range: 0000-0065	Factory set: 0003
------------	------------------------------------	--------------------------	-------------------

**LED “0” digit: Modbus communication baud rate:** set the communication baud rate

0: 1200 bps

1: 2400 bps

2: 4800 bps

3: 9600 bps

4: 19200 bps

5: 38400 bps

6: 57600 bps

**LED “00” digit: LED ten: Can (VEICHI Can)**

0: 20 kbps

1: 50 kbps

- 2: 100kbps
- 3: 125kbps
- 4: 250kbps
- 5: 500kbps
- 6: 1Mbps

**LED “000” digit:Reserved**

**LED “000” digit:Reserved**

F13.0 3	Modbus data format	Setting range: 0-5	Factory set: 0
------------	--------------------	--------------------	----------------

Set the data format when Modbus communication. If the data format is different, communication will not be possible.

- 0: (N, 8, 1) no checkout, Data digit: 8, Stop digit: 1
- 1: (E, 8, 1) even checkout, Data digit: 8, Stop digit: 1
- 2: (O, 8, 1) odd checkout, Data digit: 8, Stop digit: 1
- 3: (N,8,2) no checkout,Data digit:8, Stop digit:2
- 4: (E,8,2) even checkout,Data digit:8, Stop digit:2
- 5: (O,8,2) odd checkout,Data digit:8, Stop digit:2

F13.04	Communication ratio setting	Setting range: 0.00-5.00	Factory set: 1.00
--------	-----------------------------	--------------------------	-------------------

The data in communication address 0x2000 or 0x3000of upper machine multiply this parameter is communication giving of this machine. Upper machine communication order can be modified pro rate.

F13.05	Modbus communication answer delay	Setting range: 0.1-100.0s	Factory set: 1.0s
--------	-----------------------------------	---------------------------	-------------------

It defines the intermediate interval between sending data to the upper machine after the data is accepted. While inverter is Modbus communication slave machine,While delay time is shorter than system dealing time, real delay time is same as system dealing time. While delay time is longer than system dealing time, it has to delay while system dealing finished. It does not send data to upper machine until delay time arrive.

This parameter defines the frequency converter as the Modbus communication master station. The delay is the transmission interval of the host, and the internal limit is 2.5 characters.

F13.0 6	Modbus communication overtime fault time	Setting range: 0.1-100.0s	Factory set: 1.0s
F13.0 7	Modbus communication fault act mode selections	Setting range: 0-3	Factory set: 1

**Modbus communication overtime fault time:** If the interval between one communication and next communication is over communication overtime, it is considered as communication break fault. **[F13.07]** decides the act mode.

**LED “0” digit: Modbus communication fault act mode selections**

**0: No checkout overtime fault** No fault checkout. Inverter runs according to the last communication command.

**1: Alarm and stop freely** If it has not received the next frame order or the communication order while the latest communication giving order is over [F13.06] time setting, inverter alarms fault E.CE and stops.

**2: Alarm, go on running** While inverter running command is given by communication, if it has not received the new communication order while the latest communication giving order is over [F13.06] time setting, inverter alarms **10.074** and runs according to the last order.

**3: Forced stop** Frequency inverter stop while communication giving order is over than [F13.06] setting time and does not receive next frame order or other communication order.

**LED “00” digit: Reserved**

F13.08	Modbus transmission response	Setting range:0-1	Factory set: 0
--------	------------------------------	-------------------	----------------

The parameter chooses whether to respond when the upper machine sends a write command to the drive. If the upper computer needs the reply from the drive, the drive will occupy sharing communication bus; when doing communications control, the upper computer needs to retain enough time to reply. If the upper computer does not need a reply message but only send commands to the drive, you can choose no response to write operation to improve the utilization efficiency of the communication bus. This parameter is valid only for write operation, invalid for read operation.

**0: write operation with response**

**1: write operation without response**

F13.09	Modbus main machine sending selections	Setting range: 0000-BBBB	Factory set: 0031
--------	--	--------------------------	-------------------

Set the data that inverter sent the slave machines when inverter is main machine. All slaves will receive the command from the host when the main machine sends broadcast commands.

The host can send four polling data, corresponding to the settings of LED “0” digit, “00” digit, “000” digit and “0000” digit. No data is transmitted when invalid.

**LED “0” digit: 1st group of frame selection**

0: Invalid

1: Main machine run command

2: Main machine given frequency

3: Main machine output frequency

4: Main machine upper limit frequency

5: Main machine given torque

6: Main machine output torque

7: Reserved

8: Reserved

9: Main machine given PID

A: Main machine feedback PID

B: Reserved

C: active current component

**LED “00” digit: 2nd group of frame selection** as above

**LED “000” digit: 3rd group of frame selection** as above

**LED “0000” digit: 4th group of frame selection** as above

Host broadcast data	Corresponding address and application accepted by Slaver
1: running command given	0x3001, Can be used as the data of running command given source 0x01:FWD run 0x02:REV run 0x03:FWD jog 0x04:REV jog 0x05:Stop command (Slave machine stops according stop mode)
2: Main machine given frequency	0x3000, can be used as communication given frequency
3: Main machine output frequency	0x3000, can be used as communication given frequency
4: Main machine upper limit frequency	0x3004, can be used as communication given frequency upper limit
5: Main machine given torque	0x3005, can be used as communication given torque
6: Main machine output torque	0x3005, can be used as communication given torque
7: Reserved	
8: Reserved	
9: Main machine given PID	0x3008, can be used as PID communication given
A: Main machine feedback PID	0x3009, can be used as PID communication given

F13.10	RS485	communication	port	Setting range: 0-2	Factory default: 0
--------	-------	---------------	------	--------------------	--------------------

### RS485 communication port configuration

**0: Modbus communication:** general Modbus method

**1: Serial port monitoring:** monitoring inverter running state by upper machine.

**2: Reserved**

F13.1 6	Expansion port communication disconnection processing	<p><b>LED “0” digit t:</b> EX-A port disconnection action mode</p> <p><b>LED “00” digit:</b> EX-B port disconnection action mode</p> <p>0: no detection</p> <p>1: alarm and free parking</p> <p>2: Warning and continue to run</p>	Factory default: 0
------------	---	--	-----------------------

### LED “0” digit: Set EX-A port disconnection action mode

0: no detection

1: alarm and free parking

2: Warning and continue to run

**LED “00” digit: set EX-B port disconnection action mode**

0: no detection

1: alarm and free parking

2: Warning and continue to run

F13.17	Expansion port EX-A parameter	Setting range: 0~2	Factory default: 0
F13.18	Expansion port EX-B parameter	Setting range: 0~2	Factory default: 0

**LED “0” digit: EX-A port disconnection action mode**

0: no detection

1: alarm and free parking

2: Warning and continue to run

**LED “00” digit: EX-B port disconnection action mode**

0: no detection

1: alarm and free parking

2: Warning and continue to run

F13.19	Expansion port EX-A monitoring frame address group 1	Predetermined area: LED digits ten digits: address lower 8 digits 00~63 LED hundred thousand digits: address high 8 digits 00~07	Factory default: 0001
F13.20	Expansion port EX-A monitoring frame address group 2	Setting range: Same as above	Factory default: 0002
F13.21	Expansion port EX-A monitoring frame address group 3	Setting range: Same as above	Factory default: 0007
F13.22	Expansion port EX-A monitoring frame address group	Setting range: Same as above	Factory default: 0011

**LED “0” and “00” digits:** up and down keys to modify the serial number 00 ~ 99**LED “000” and “0000” digits:** up and down keys modify group number 00~15,

For example, set F13.19 to 0001 for C00.01 then do it by that analogy.

F13.23	Expansion port EX-B monitoring frame address group 1	Predetermined area: LED digits ten digits: address lower 8 digits 00~63 LED hundred thousand digits: address high 8 digits 00~07	Factory default: 0001
F13.24	Expansion port EX-B monitoring frame address group 2	Setting range: Same as above	Factory default: 0002

F13.25	Expansion port EX-B monitoring frame address group 3	Setting range: Same as above	Factory default: 0007
F13.26	Expansion port EX-B monitoring frame address group 4	Setting range: Same as above	Factory default: 0011

**LED “0” and “00” digits:** up and down keys to modify the serial number 00 ~ 99

**LED “000” and “0000” digits:** up and down keys modify group number 00~15,

For example, set F13.23 to 0001 for C00.01 then do it by that analogy



## 6.14 F14: Photovoltaic Pump Special Parameters

F14.0  0	Photovoltaic water  pump mode	LED0 Mode selection 0: Frequency conversion mode 1: CVT mode 2: MPPT mode LED1 work selection 0: continuous operation 1: intermittent operation 2: cleaning water pump (keyboard displays CLRER) LED2 reserved LED3 motor selection 0: three-phase motor 1: single-phase motor	Factory default:0002
----------------	-------------------------------------	---	----------------------

Note:

- When LED1 is set to 1 (intermittent operation) or set to 2 (water pump cleaning), the execution must be valid when LED0 is set to CVT or MPPT mode. When 2 is selected to "clean the water pump", this bit will automatically be executed after the execution is completed. If it is cleared, this bit will also be automatically cleared when the machine is stopped during cleaning.
- When LED3 is selected as a single-phase motor, parameter F08.00=5, F10.15 ones digit is set to 0, F14.14=30, F14.16=300 will be automatically configured.

### Description:

**Inverter speed control mode:** Photovoltaic control does not work: if you need to run in normal mode, set it to inverter speed regulation mode. Turn off the photovoltaic water pump mode. At this time, the inverter can only perform a single frequency conversion and voltage regulation, it can control the machine to start and stop and change the speed, but the photovoltaic function parameters cannot be applied.

**CTV mode:** CVT (Constant Voltage Tracking) is constant voltage tracking, by adjusting the output frequency, the bus voltage is stabilized at a given operating point; the frequency command generated by the CVT module is sent to the inverter circuit to realize the speed control of the motor.

The bus voltage is given as a constant value mode, and the CTV target voltage value is in the form of a percentage, which is compared with the percentage of the machine's open circuit voltage - the bus voltage during standby, by comparing this value with the voltage generated by the photovoltaic, and then calculate Whether the inverter needs to be down-frequency or up-frequency;

MPPT mode: MPPT (Maximum Power Point Tracking) is the maximum power point tracking, searching for the maximum power point according to the bus voltage  $V_{pn}$  and operating frequency, and outputting the bus voltage target value  $V_{pn}^*$  at the maximum power point.

### MPPT Mode running process

1.1 Start acceleration and deceleration stage: Acceleration at the rate set by acceleration and deceleration time 1 (with the maximum frequency as the time reference). Due to the difference between the solar power panel and the power grid, with the increase of the output frequency of the inverter, the bus voltage will continue to decrease. If it runs to a given frequency, the bus voltage still does not drop to the CVT target voltage value (F14.03), then it keeps running at constant speed during the start-up and deceleration phase.

1.2 Until the current bus voltage reaches the turning point (set value + 8.0%\*Voc), the acceleration slows down, and enters the CVT stage after reaching the voltage set value.

1.3 CVT stage: Adjust the frequency according to the error between the given and feedback, keep the bus constant, the gain is determined by F14.06 (frequency adjustment gain), the default value of 10.0% is the best setting; if the output frequency reaches the given frequency, Then exit the CVT stage and enter the start-up acceleration and deceleration stage, because the power of the battery board is sufficient to support the full-load operation of the motor; when the output frequency does not reach the given frequency, after the CVT is adjusted and stabilized (the voltage deviation is less than 5.0%) to enter the MPPT stage;

1.4. MPPT stage: Take the MPPT search interval (F14.07) as the period to search for the maximum power point.

Continuous operation: The inverter is always in the running state, and the photovoltaic voltage is always detected and compared with the bus voltage to run the water pump.

### Indirect operation: intermittent operation of functional logic

1.1. This function is mainly used in the field where some farmland does not need to be irrigated all the time, and the irrigation is controlled by intermittent operation.

1.2. When F14.00 tenth digit is set to 1, the intermittent operation function will be opened. After opening, press the operation key to run the intermittent operation start time set in F14.55.

1.3. After the running completion time is reached, it is fixed to decelerate to 0Hz according to the deceleration stop method (F07.10with F14.53Ten digit is selected as free stop or deceleration stop), maintain the intermittent operation stop time set in F14.56 at 0hz, and then run again until the number of intermittent operation repeats set in F14.54 is reached.

1.4, When one of the parameters of F14.55 intermittent operation start time or F14.56 intermittent operation stop time is set to 0, intermittent operation will not be performed.

1.5. When setting the ones digit of F14.53 to 1, the next time it starts to run, it will continue to run in the running state before the last power failure (the number of repetitions of the previous shutdown, the time of the running phase or the time of the stop phase), when it is set to 0, When set to 0, it will run again after re-powering.

1.6. Deceleration to 0Hz when the tenth digits of F14.53 is set to "0" for Photovoltaic specific alarm output, and the output will be stopped immediately when set to "1".

## Cleaning the water pump: The logic of the pump cleaning function

- 1.1. The pump stall (pump cleaning) function is defined as the function to remove impurities from the water pump.
- 1.2. After setting F14.00's tenth digits to 2, press the Run key, and the keyboard will display ClrEr. At this time, it will enter the pump cleaning state.
- 1.3. During cleaning, it will run to the cleaning set frequency (F14.57) according to the acceleration time 1. First run F14.58 in the forward direction and then decelerate to 0Hz. Wait for 2s before running F14.59 in the reverse direction to clean the reverse operation time.
- 1.4. One cycle of forward and reverse operation is counted as one cycle, and the shutdown state is restored after the set cleaning cycle number F14.60 is run.
- 1.5. If the stop button is pressed during the pump cleaning, the cleaning process will be stopped immediately, and the machine will be stopped according to the currently set stop mode; Whether the pump cleaning process is completed or the pump is stopped midway, the ten positions of F14.00 will be reset after the completion.
- 1.6. When any parameter from F14.57 to F14.60 is set to 0, this function will not be executed, and no current will be output at 0 speed. Test record: 1. When the frequency is 0, the keyboard does not display CLERE, and the current is not output when the frequency is 0. After manual shutdown, the tenth digit of F14.00 will not be reset. 2. It is the same when the forward and reverse rotation time is 0; 3. It is the same if the number of times is set to 0.

Three-phase motor: For the motor we normally use, 380V three-phase motor does not need to set other parameters.

Single-phase motors:

- 1.1. It is troublesome for customers to set single-phase motor parameters every time, so a macro parameter is set to facilitate customers to change parameters,
- 1.2. When the hundreds digit of F14.00 is set to 1, F04.00 (V/F curve selection) will be automatically set to 5; F10.20 bit (output phase loss protection) is set to 0; F14.14 (detection frequency of low frequency protection) is set to 30Hz; F14.16 (Automatic recovery time of low frequency protection) is set to 300s.
- 1.3 When F14.00 is switched to 0, the above four parameters will change back to the values before change.

Verify it and enter it manually if it has not changed.

F14.0 1	Operating status	0: Stop 1: Run 2: Sleep 3: Low frequency protection 4: dry running protection 5: Overcurrent protection 6: Low power protection 7: Water full protection	0 (read only)
------------	------------------	---	---------------

Used to read the operating status of the inverter to determine whether there is a fault in the motor operation (only read)

F14.0 2	VOC voltage (display)	0.0V - 999.9V	0.1V (read only)
------------	-----------------------	---------------	------------------

Voc is the open-circuit voltage. The Voc is equal to the bus voltage during shutdown and is used to read parameters.

F14.0 3	CVT target voltage	70.0% - 95.0%	81.0%
------------	--------------------	---------------	-------

Applied to CTV mode parameters, CVT target voltage = percentage value \* static open circuit voltage. Compared with the bus voltage, the frequency is increased below the target voltage frequency, and the frequency is decreased above the target voltage.

F14.0 4	MPPT voltage upper limit	20.0% - 200.0%	100.0%
F14.0 5	MPPT voltage lower limit	20.0% - 200.0%	50.0%

The upper and lower limits of the voltage in MPPT mode, the customer can select the upper and lower limit values according to the requirements, the inverter will search for the maximum power point according to the operating frequency and output the target value of the bus voltage at the maximum power point;

F14.0 6	Frequency adjustment gain	0.1% - 500.0%	10.0%
F14.0 7	MPPT search interval	0.1 - 30.0	1.0sec

The gain adjustment of frequency change mainly means that when the frequency is close to the target voltage, the frequency changes slowly, and increasing the gain can make the frequency change rapidly (the test found that 10% is the best);

In MPPT mode, the time interval for cycle frequency adjustment can be set;

F14.0 8	MPPT gain	0-9999	100
------------	-----------	--------	-----

F14.0 9	Fast frequency reduction gain	0-20	2
------------	----------------------------------	------	---

MPPT gain: Make the MPPT operating situation respond faster and feedback more quickly. At the same time, when it can run stably in MPPT mode, increasing the gain can appropriately increase the output frequency and voltage stability. (Do not debug at will)

Fast throttling gain: speed guidance for throttling.

F14.1 0	Frequency adjustment filter time	0.001s - 2.000s	0.020s
------------	-------------------------------------	-----------------	--------

When the voltage is stable, the frequency fluctuation can increase the filtering time appropriately.

F14.1 1	Sleep voltage threshold	0 to 1000V	0V
F14.1 2	Sleep recovery voltage	0 to 1000V	400V
F14.1 3	Sleep shutdown waiting time	0.0sec~3000.0sec	10.0sec

Display A.LPn when alarming, set F14.11 to 0 to close sleep

Sleep logic: Set according to customer requirements

- 1.1. When the frequency is in operation and the bus voltage is less than F14.11 sleep voltage threshold, report A.LPn warning immediately.
- 1.2. After the alarm, the inverter will decelerate or stop freely according to the tenth digit setting of F14.53.
- 1.3. When the bus voltage rises to F14.12 sleep recovery voltage, after F14.13 sleep shutdown waiting time, the inverter starts to operate from zero frequency (free shutdown) or from the current frequency (deceleration shutdown).
- 1.4. If F14.11 sleep voltage is set to 0, turn off low voltage protection.
- 1.5. The low voltage protection can still be triggered under the state of deceleration shutdown. After the protection is triggered, the shutdown will be carried out according to the tenth digit setting of F14.53, and the operation will not be resumed after the shutdown.
- 1.6. If the voltage drops to the sleep voltage again during the sleep shutdown waiting time, the inverter will not resume operation. Each detection time is independent of each other and will not be accumulated.

F14.1 4	Detection frequency of low frequency protection	0.00Hz ~300.00Hz	0.00Hz
F14.1 5	Detection time of low frequency protection	0.0sec~3000.0sec	10.0sec
F14.1 6	Automatic recovery time of low frequency protection	0.0sec~3000.0sec	10.0sec

In case of alarm, A.LFr is displayed, and F14.14 is set to 0 to turn off low frequency protection

Judgment time of low frequency protection exit is related to F14.16.Low frequency protection does not increase sleep times F14.16

#### Low frequency protection

- 1.1. When the inverter is in CVT regulation state and the output frequency is less than the frequency detected by F14.14 low frequency protection, the A.LFr warning is reported after F14.15 low frequency protection detection time.
- 1.2. After the alarm, the inverter will decelerate or stop freely according to the tenth digit setting of F14.53.
- 1.3. From the alarm alarm point, after F14.16 low frequency protection automatic recovery time, the inverter starts to operate from the current frequency.
- 1.4. If the detection frequency of F14.14 low frequency protection is set to 0, the low-voltage protection is closed.
- 1.5. Low frequency protection can still be triggered under the state of deceleration shutdown. After the protection is triggered, the shutdown will be carried out according to the tenth digit setting of F14.53, and the operation will not be resumed after the shutdown.
- 1.6. If the frequency increases to above the detected frequency of low frequency protection within the detection time of low frequency protection, the inverter will not alarm the low frequency protection warning, and each detection time is independent of each other and will not be accumulated.

F14.1 7	Detection current of dry running protection	0.0 - 999.9A	0.0A
F14.1 8	Detection time of dry running protection	0.0sec~3000.0sec	10.0sec

F14.1 9	Automatic recovery time of dry running protection	0.0sec~3000.0sec	10.0sec
------------	---	------------------	---------

The alarm displays A.LuT, and the dry running protection is turned off when F14.17 is set to 0

100.0% corresponding motor rated current

Dry running protection: In order to protect the water pump, the current is kept very low, which will seriously affect the motor.

#### 1. Dry running protection 1 logic

1.1. When the inverter is in operation, the F14.29 thousands digit is zero and there is no sensor and the output current is less than F14.17 after hitting the dry running protection detection point, the A.LuT alarm is reported after F14.18 dry running detection time.

1.2. After the alarm, the inverter will decelerate or stop freely according to the tenth digit setting of F14.53.

1.3. The timing starts after the alarm. After the F14.19 dry running protection recovery delay, the inverter starts to run from the current frequency.

1.4. If F14.17 dry running protection detection point is set to 0, the dry running protection is closed.

1.5. The dry running protection can still be triggered under the deceleration shutdown state, after the protection is triggered, the machine will be shutdown according to the tenth digit setting of F14.53. After the shutdown, the machine will not resume operation again.

1.6. If the output current increases above the protection point within the detection time of dry running protection, it will not enter the dry running protection again. Each detection time is independent of each other and will not be accumulated.

#### 2. Dry running protection 2 logic

2.1. When the inverter is in operation, F14.29 thousands digit has a sensor, and any X terminal input function is set to 83 and is effective, the detection stage of dry running protection will enter, and other logic is the same as that of dry running protection 1.

F14.2 0	Detection current of overcurrent protection	0.0 - 999.9A	0.0A
F14.2 1	Detection time of overcurrent protection	0.0sec~3000.0sec	10.0sec

F14.2 2	Automatic recovery time of overcurrent protection	0.0sec~3000.0sec	10.0sec
------------	---	------------------	---------

**Display A.Old in case of alarm.F14.20 Turn off overcurrent protection when it is set to 0**

Overcurrent protection: Overcurrent protection parameters

- 1.1. When the inverter is in operation and the output current is greater than F14.20 overcurrent protection detection point, the A.Old alarm is reported after F14.21 overcurrent detection protection time.
- 1.2. After the alarm, the inverter will decelerate or stop freely according to the tenth digit setting of F14.53.
- 1.3. Start timing after the alarm. After F14.22 overcurrent protection recovery delay, the inverter starts to run from the current frequency.
- 1.4. If F14.20 overcurrent protection detection point is set to 0, the overcurrent protection is closed.
- 1.5. The overcurrent protection can still be triggered under the state of deceleration shutdown. After the protection is triggered, the shutdown will be carried out according to the tenth digit setting of F14.53, and the operation will not be resumed after the shutdown.
- 1.6. If the output is reduced below the protection point within the detection time of overcurrent protection, it will not enter the overcurrent protection again. Each detection time is independent of each other and will not be accumulated.

F14.2 3	Minimum power protection value	0.00kw - 650.00kw	0.00kw
F14.2 4	Minimum power protection detection time	0.0sec~3000.0sec	10.0sec
F14.2 5	Minimum power protection automatic recovery time	0.0sec~3000.0sec	10.0sec

**Display A.LPr in case of alarm,F14.23 Turn off the minimum power protection when it is set to 0**

Minimum power protection: It is also to protect the water pump, when the running current is small, the power is relatively small. From different dimensions.

- 1.1. When the inverter is in operation and the output power is less than F14.23 minimum power protection detection point, report A.LPr after F14.24 minimum power protection detection time.
- 1.2. After the alarm, the inverter will decelerate or stop freely according to the tenth digit setting of F14.53.
- 1.3. The timing starts after the alarm. After the F14.25 minimum power protection recovery delay, the inverter starts



to run from the current frequency.

1.4. If F14.23 minimum power protection detection point is set to 0, the minimum power protection is closed.

1.5. The minimum power protection can still be triggered under the state of deceleration shutdown. After the protection is triggered, the shutdown will be carried out according to the tenth digit setting of F14.53, and the operation will not be resumed after the shutdown.

1.6. If the output power increases above the protection point within the minimum power protection detection time, the minimum power protection will not be entered again. Each detection time is independent of each other and will not be accumulated.

F14.2 6	Alarm recovery mode	0: Automatic recovery; 1: Manual recovery LED0: Low frequency protection LED1: dry running protection LED2: overcurrent overload protection LED 3: minimum power protection	0000H
------------	---------------------	---	-------

**If set to manual recovery, The recovery time of various protections is invalid**

When the protection alarm is triggered, automatic recovery and manual recovery can be selected according to this parameter. The automatic recovery time of the corresponding protection for manual recovery is invalid, and the automatic recovery will be used normally again according to the time. During the fault warning display, you can also press and hold the "RESET" key to stop the machine; When 1 is selected for manual recovery, the fault alarm can be cleared manually by pressing the "RESET" key, or the shutdown operation can be realized by long pressing the "RESET" key.

F14.2 7	Detection time of water full protection	0.0sec~3000.0sec	10.0sec
F14.2 8	Exit time of water full protection	0.0sec~3000.0sec	10.0sec

**Display A.FuL in case of alarm; Turn off water full protection when set to time =0**

**Full water protection:** It is used to draw water from the pool to judge the water level.

Water full protection logic

1.1. During field use, there are two water full detection points, namely upper limit and lower limit. When the water volume exceeds the upper limit, the water full protection will be triggered. When the water volume drops below the lower limit, the water full protection phase will be exited to achieve the hysteresis effect.

1.2. Therefore, in the function code of terminal X, 80: photovoltaic water full detection alarm is the upper limit, and 81: photovoltaic water full detection alarm reset is the lower limit. When the water volume reaches the upper limit, the lower limit will be triggered; When exiting the lower limit, it must exit the upper limit. Therefore, when the two terminals are effective at the same time, the water full protection alarm will enter. If it is invalid at the same time, exit the water full protection alarm.

1.3. When the inverter is in operation and both terminals are valid at the same time, after F14.27 water full detection time, report A.FuL alarm. After the alarm is reported, the inverter will decelerate or stop freely according to F14.53 tenth digit setting.

1.4. If F14.27 water full detection time is set to 0, turn off water full protection.

1.5. Start timing after the alarm. After F14.28 water full protection recovery delay, the inverter starts running from the current frequency.

1.6. The water full protection can still be triggered under the state of deceleration shutdown. After the protection is triggered, the shutdown will be carried out according to the tenth digit setting of F14.53, and the operation will not be resumed after the shutdown.

1.7. If the water level drops below the lower limit during the detection time of water full protection, it will not enter the water full protection again, and each detection time is independent of each other and will not be accumulated.

F14.2 9	Auxiliary functions	0: invalid, 1: valid LED0:0: upper limit is limited by given frequency, 1: upper limit frequency is limited by rated frequency of motor LED1:0: lower limit minimum to 0 1: lower limit frequency minimum to 1/4 of motor rated frequency LED2: fault power-off storage LED 3: dry running out protection selection 0: Sensorless protection (current judgment) 1: With sensor protection 2: Slow down operation (single-phase motor disabled)	0110H
------------	---------------------	---	-------

**Note:** When LED 3 is selected as 2, it means that the current is judged to be dry running. When the current is in dry running protection, the current output frequency is reduced to 7% of the rated frequency. In this case, the current rises > F14.20 + 0.4A (0.4 is hysteresis), and the dry running protection exits, and the frequency recovers.

Auxiliary parameter setting, according to other functions to set this parameter

F14.3 0	DC current derivation offset	0-99.99A	0.00A
F14.3 1	DC current extrapolation gain	0-999.9%	100.0%

If you find that the DC current is not detected correctly, you can adjust F14.30 and F14.31 for recalibration.

F14.3 2	Power curve point 0	0.00kw - 99.99kw	0.50kw
F14.3 3	Power curve point 1	0.00kw - 99.99kw	1.00kw
F14.3 4	Power curve point 2	0.00kw - 99.99kw	1.50kw
F14.3 5	Power curve point 3	0.00kw - 99.99kw	2.00kw
F14.3 6	Power curve point 4	0.00kw - 99.99kw	2.50kw
F14.3 7	Flow curve point 0	0.0 - 999.9m <sup>3</sup> /h	0.0 m <sup>3</sup> /h
F14.3 8	Flow curve point 1	0.0 - 999.9m <sup>3</sup> /h	5.0 m <sup>3</sup> /h
F14.3 9	Flow curve point 2	0.0 - 999.9m <sup>3</sup> /h	10.0m <sup>3</sup> /h
F14.4 0	Flow curve point 3	0.0 - 999.9m <sup>3</sup> /h	15.0m <sup>3</sup> /h
F14.4 1	Flow curve point 4	0.0 - 999.9m <sup>3</sup> /h	20.0m <sup>3</sup> /h
F14.4 2	Flow calculation correction offset	0.0m <sup>3</sup> - 999.9 <sup>3</sup>	0.0m <sup>3</sup>
F14.4 3	Flow calculation correction gain	0.1% - 500.0%	100.0%

F14.4 4	Daily flow/daily power clearing cycle	0.1 - 24.0Hr	7.0Hr
F14.4 5	Reserved	0-9999	0

#### PQ curve function

This model provides custom PQ curve, which can be used by users to set 5 groups of PQ correspondence points according to the water pump situation to realize real-time flow rate, daily flow rate, cumulative flow rate, daily power generation and cumulative power consumption calculation; among them, by default, daily flow rate and daily power generation are calculated in a 7h day.

F14.4 6	Photovoltaic pump function selection 1	0: invalid, 1: effective LED0: constant torque frequency limiting selection LED1: reserved LED2: voltage surge update Voc voltage LED3: fast downscaling function	1100H
------------	--	---	-------

**Constant torque frequency limit selection:** The application is used in the field where the torque is constant all the time. When the torque is constant and the load is small, the frequency will increase all the time and we need to set a limit value to it to do the limitation, then this value can be designed.

#### Constant torque frequency limiting function logic

- 1.1. When setting 14.46 digits: The function is turned on when constant torque frequency limit is selected as 1.
- 1.2. The output voltage and frequency are limited by setting F14.48 Constant Torque Frequency Limiting.
- 1.3. If the set value is less than or equal to 100%, the output voltage and output frequency will be limited according to the set percentage \* current bus voltage.
- 1.4. If the setting value is greater than 100%, the output voltage will be limited to 100%, i.e. the maximum output voltage cannot exceed the current bus voltage/1.414, but the output frequency will continue to increase proportionally. Voltage surge update Voc voltage: Voc is the open circuit voltage, the size of Voc is equal to the bus voltage during shutdown, the Voc voltage is projected and continuously updated slowly according to the current bus voltage during operation, and when the bus voltage suddenly rises, a large update of the Voc voltage is required immediately to ensure the normal operation of the PV system.

- 1.1. When F14.46 hundred is selected as 1, the function of updating Voc voltage by voltage surge is turned on. When the bus voltage exceeds the voltage surge threshold F14.49, this function is valid and the Voc voltage is updated immediately.

Fast downscaling function: When the photovoltaic normal operation process, suddenly encounter a dark cloud shading, then the panel power will be significantly reduced, the bus voltage will fall quickly, in order to prevent the sudden bus voltage change to pull the inverter crotch, use this function to adjust the output frequency quickly down.

1.1. Set F14.46 kilobits to 1 to turn on the fast frequency reduction function. When the voltage drop exceeds the F14.47 fast frequency reduction threshold, it enters the fast frequency reduction process and the output frequency drops rapidly to 3Hz.

1.2. After maintaining 1s at 3Hz, if Voc does not change significantly, continue to reduce to 0hz to maintain 4s, and after 4s restart with the start acceleration phase.

1.3. After starting with the acceleration phase, if there is no big change in Voc, when it enters CVT mode, it will enter 3Hz fast downscaling mode again and repeat the cycle.

1.4. After the dark clouds pass and the bus voltage rises significantly to perform the start-up in an accelerated phase, it enters the normal operation phase.

F14.4 7	Fast downsampling threshold	3.0%-15.0%	5.0%
F14.4 8	Constant torque frequency limiting	80.0%-150.0%	100.0%
F14.4 9	Voltage Surge Threshold	0.0%-20.0%	5.0%
F14.5 0	Reserved	1-40	10
F14.5 1	Reserved		
F14.5 2	Reserved		

The above parameters are operated according to the PV pump function selection. The specific requirements and operations can be based on the above parameters explained for parameter selection.

F14.5 3	Intermittent operation and alarm shutdown settings	LED0: intermittent operation storage options 0: no storage 1: storage LED1: Alarm output stop selection 0: speed reduction to 0Hz 1: stop output immediately LED2: Reserved LED3: Reserved	0x0000
------------	--	--	--------

1、 When LED0 selects "1" for storage, the next start-up operation will continue to run in the same state as before the last power-down (the number of repetitions of the previous stop, the running phase time or the stop phase time), otherwise it will run again and the number of repetitions will be cleared to zero.

2、 LED1 is set to "0" to decelerate to 0Hz when the PV special alarm output is set to F0.15 to set the deceleration time, and "1" to stop the output immediately.

F14.5 4	Number of repetitions of intermittent operation	0~1000times	0
F14.5 5	Intermittent operation opening time	0~3000minutes	0
F14.5 6	Intermittent running stop time	0~3000minutes	0
F14.5 7	Cleaning setting frequency	0.00Hz~300.00Hz	25.00Hz
F14.5 8	Cleaning positive running time	0~3000s	30
F14.5 9	Cleaning reverse running time	0~3000s	30
F14.6 0	Number of cleaning cycles	0~60times	5

The above parameters are mainly selected according to the F14.00 function, the function is turned on and then debug parameters here, please check the F14.00 guidance notes for specific operations.

F14.6 1	Power upper limit	0.0~1000.0	0.0
F14.6 2	Power limit Kp	0.0~100.0	1.0
F14.6 3	Power limit Ki	0.0~100.0	1.0

#### F14.61: Set to 0 to run without limiting the power limit

Power Limit: Parameters used to control the output power

The power limit is determined by F14.61-F14.63, and the power limit function is turned off when F14.61 is 0. Set the upper power limit value of F14.61 and adjust F14.62 and F14.63 so that the output power during operation cannot exceed the value set by F14.61. The power display is changed to kW effective.

## Chapter 6 Operation Guidance

### 6.1 AM Motor Pump Drive Operation Guidance (Keyboard as an example)

#### 1) Wiring

- ①. Confirmed the solar pump drive if mating with motor.
- ②. Correctly connecting "+" "-" of solar panel to corresponding "+" "-" pole of inverter or R, T wiring terminals Otherwise it will cause inverter damage.
- ③. Connect motor wire and ground wire to corresponding U, V, W, E terminals.

#### 2) Parameters setting and trial run

- ①. Set F0.00 to 0, F0.02 for 0, and F0.09, F0.11, F0.14, F0.15 parameters setting according to application site.
- ②. Set motor(pump) parameters according to nameplate of pump.
- ③. Set solar pump MPPT mode F14.001 for 1 or 2.
- ④. Press FWD button for trial running, and confirm the motor running direction.

#### 3) Common problems

- ①. Q:Well-lit conditions, the pump is running, but the water is very small.  
A:Check if the pump motor direction is reversed.
- ②. Q:Well-lit conditions, the drive is in standby mode 0.00Hz.  
A:Check F14.01, observe what protection status is the drive in currently, check whether the parameters set is reasonable.
- ③. Q:DC current is incorrectly displayed.  
A:Adjust F14.30, F14.31 for calibration.
- ④. Q:Well-lit conditions, frequency severe beating during operation.  
A:Reasonably adjust F14.06 value, the adjustment is recommended to be in the vicinity of the default, too big or too small will cause frequency oscillation.

## 6.2 Synchronous Motor Pump Drive Operation Guidance

### 1) Wiring

- ①. Confirm if the solar pump drive matches with the motor.
- ②. Connecting “+” of solar panel to corresponding “+” of inverter or R, T wiring terminals. Otherwise it will cause inverter damage.
- ③. Connect motor wire and ground wire to corresponding U, V, W, E terminals.

### 2) Parameters setting and trial run

- ①. Set F0.00 to 6, F0.02 for 0, and F0.09=100.00, F0.11=100.00; F0.14, F0.15 can be set according to demand.
- ②. Set motor (pump) parameters according to nameplate of pump. Then Set F5.20 for 1, the keypad will show T-00, press FWD to start motor auto tuning. This process takes about three minutes.

Note:

1. If you can disconnect the motor and load, self-learning would be better.
2. The self-learning need to be done with enough sunshine and when the solar panels can provide enough energy.
- ③. Set solar pump MPPT mode F14.001 for 1 or 2.
- ④. Press FWD button for trail running, and confirm the motor running direction.

### 3) Common problems and solutions

- ①. Q:Well-lit conditions, the pump is running, but the water is very small.  
A:Check if the pump motor direction is reversed.
- ②. Q:Well-lit conditions, the drive is in standby mode 0.00Hz.  
A:Check F14.01, observe what protection status is the drive in currently, check whether the parameters set is reasonable.
- ③. Q:DC current is incorrectly displayed.  
A:Adjust F14.30, F14.31 for calibration.
- ④. Q:Well-lit conditions, frequency severe beating during operation.  
A:Reasonably adjust F14.06 value, the adjustment is recommended to be in the vicinity of the default, too big or too small will cause frequency oscillation.
- ⑤. Q:The current fluctuation is huge when the pump is running.  
A:Check C02.39, adjusting the value of F5.24, so the C02.39 displays the value from 0-10.

## 6.3 PV Water Pump Features

### A. Sleep Function

During the photovoltaic pump operation, the inverter will go into sleep state when the DC voltage provided by solar panels is lower than FE.11 (sleep voltage threshold) due to objective factors, while the keyboard warning "A.LPn"; when DC voltage provided by solar panels rises back to F14.12 (sleep recovery voltage) point, start timing and after FE.13 (sleep shutdown waiting time), the drive starts running.

### B. Low-frequency Protection Function



During the operation of the photovoltaic pump, for some reason, the output frequency is lower than F14.14 (low frequency detection frequency), and after F14.15 (under frequency detection time) time, enters into the standby protection state, while the keyboard warning "A.LFr"; after entering into the standby protection state and after F14.16 (frequency protection automatic recovery) time, automatically resume to running state.

### C. Dry Run Protection

During the operation of the photovoltaic pump, for some reason, the output current is less than F14.17 (dry protection current detection), and after F14.18 (dry protection detection time) time, enters into standby protection state, while the keyboard warning "A.LuT"; after entering into the standby protection state and after F14.19 (dry protection automatic recovery)time, automatically resume to running state.

### D. Over-current Protection

During the operation of the photovoltaic pump, for some reason, the output current is greater than F14.20(over current point setting), and after F14.21 (over current protection detect time) time, enters into standby protection state, while the keyboard warning "A.oLd "; after entering into the standby protection state and after F14.22 (over current protection auto recovery)time, automatically resume to running state.

### E. Minimum Power Protection

During the operation of the photovoltaic pump, for some reason, the output power is less than F14.23(minimum power protection value), and after F14.24 (minimum power protection detection time) time, enters into standby protection state, while the keyboard warning "A.LPr"; after entering into the standby protection state and after F14.25 (minimum power automatic recovery)time, automatically resume to running state.

### F. Full Water Protection

Detect the water full alarm and low water level through two X terminals, realizing automatic level control. Wherein F14.27 is the water overflow protection detection time and F14.28 is full water protection exit time, and X 3 terminal is defined as full solar water detection alarm, and X4 terminal is defined as full solar water detection alarm reset, the warning signal is shown as "A.Ful".

### G. Alarm Recovery Mode: 0: automatic recovery; 1: manual recovery

This option is for low frequency protection, dry protection, over-current protection, minimum power function; you can select the alarm restoration by F14.26. When you select 0 for automatic recovery, during fault warning displaying, you can also press the "RESET" button to stop operation; during fault warning displaying, you can press the "RESET" button to manually clear, you can also press "RESET" button to achieve stop operation.

### H. PQ Curve Function

This model provides a self-defined PQ curve for users to set up five groups of PQ corresponding points according to the pump cases, to achieve real-time traffic speed, daily flow, cumulative flow,

generating capacity, cumulative electricity consumption; of which by default, daily flow and generating capacity are calculated based on 7h in a day.J. Status Check.

When the solar pump is running, you can check FE.01 to confirm the current operating status. Chapter 6 Operation Guidance.

### **I. Status Check**

When the photovoltaic pump is running, you can check F14.01 to confirm the current operating status.