

SI23 New Machine Debugging Process (C00.28=6907)

1、Wiring Diagram

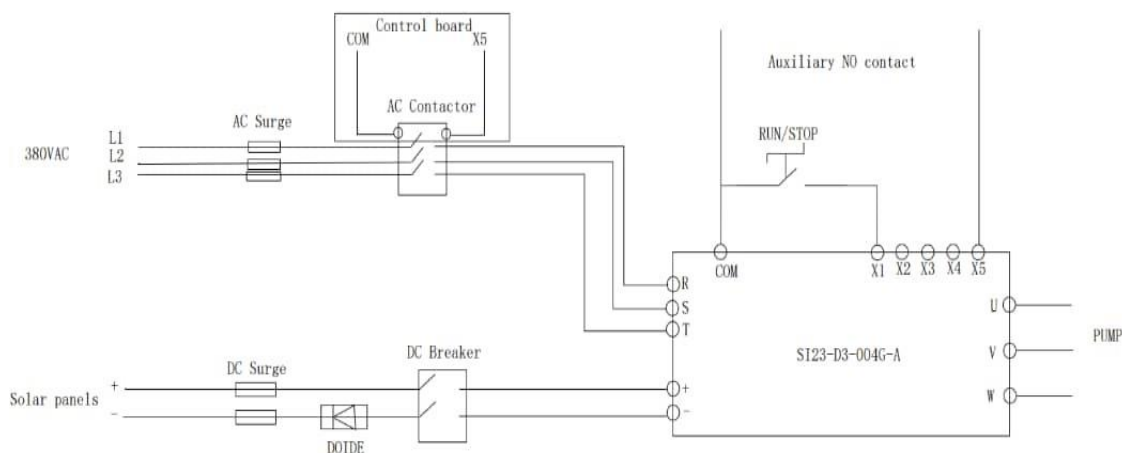

Note: D3 and D5 frequency converters have the same wiring mode, but the difference is that the input voltage levels are different, F00.19=1 is used to restore the factory value, and then it is necessary to determine whether the motor is synchronous. Select the motor control mode according to the motor type, which must be selected correctly. (When using single-phase motor, only F14.00=1002 is needed, and other parameters do not need to be adjusted)

The X5 terminal function is by default an AC/DC input function, when the DC power is not enough, we can input both AC and DC and then connect the X5 terminal to the com so that the inverter can control the motor with the highest frequency

2、Set the motor parameters and select the self-learning method at the same time (VF control mode can not input motor parameters, but for better performance, it is recommended to enter the motor parameters, and learn by motor self.)

NO.	Function name	Set value	Instruction
F00.00	control method	Induction motor: 0.VF control 1. Open loop control mode 2. Closed-loop control mode synchronous motor: 10. VF mode 11. Open loop control mode 12. Closed-loop control mode	
F05.01	Number of motor poles	Set according to the actual number of motor poles	
F05.02	Motor rated power	Set according to actual motor parameters	
F05.03	Motor rated frequency	Set according to actual motor parameters	
F05.04	Motor rated speed	Set according to actual motor parameters	
F05.05	Motor rated voltage	Set according to actual motor parameters	
F05.06	Motor rated current	Set according to actual motor parameters	
F05.20	Motor self-learning	1. Rotation self-learning (must be disconnected from the load, with encoder rotation self-learning effect is better, otherwise it may not run) 2. Static self-learning	

Note: F05.20=1/2, when T-00 appears, you need to press the green key RUN once to conduct self-learning, and then return to the monitoring interface.

Reasons for failure of self-learning:

1. The rated frequency of the motor is greater than the maximum frequency and the upper limit frequency. please modify F00.10=F00.12>=F05.03.
2. Motor parameters are not entered correctly
3. Wrong selection of motor control mode

3、Analog speed control

If you are using analog speed control, you need to dial the code. The default is voltage dial code.



If you need 4-20ma, then you need to set F03.00=2

NO.	Function name	Set value	Instruction
F00.01	Run command channel	0	0: keyboard control 1: Terminal control 2: RS485 communication control
F00.02	Frequency given channel	2	0: keyboard digital given frequency 1: reserved 2: Current/voltage analog AI1 given 3: Current/voltage analog AI2 given 4: Reserved 5: Terminal pulse PUL given 6: RS485 communication given 7: Terminal UP/DW control 8: PID control given 9: Program logic control (PLC) given 10: Optional card 11: Multi-speed given

4、 Terminal control RUN/STOP

NO.	Function name	Set value	Instruction
F00.01	Run command channel	1	0: keyboard control 1: Terminal control 2: RS485 communication control
F02.00	Multifunction input terminal (X1)	1	0: No function 1: Forward running 2: Reverse operation 3: Three wire operation control (Xi)

You need to determine the type of switch

Normally closed and normally open switch: Directly connect X1 and com to both ends of the switch, close it for operation, and disconnect it for stop

Triggered switch: press the button and it will pop up automatically F02.23=2

F02.00	Multifunction input terminal (X1)	1	0: No function 1: Forward running 2: Reverse operation 3: Three wire operation control (Xi)
F02.01	Multifunction input terminal (X2)	2	0: No function 1: Forward running 2: Reverse operation 3: Three wire operation control (Xi)
F02.02	Multifunction input terminal (X3)	3	0: No function 1: Forward running 2: Reverse operation 3: Three wire operation control (Xi)

Under this mode, the 3-wire control terminal (Xi) is a running disable terminal. The run command is produced by the forward run terminal X1, and the direction is controlled by the reverse run terminal X2. The 3-wire control terminal (Xi) is an Valid input terminal.

K1	direction control
0	forward
1	reverse

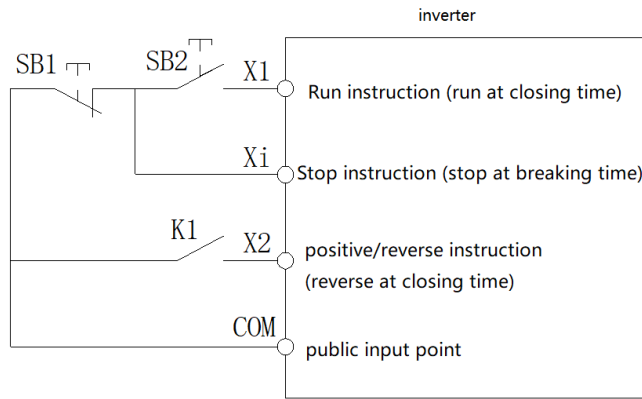

Schematic diagram of three-wire system control 1