

Quick installation guide of Three-phase energy meter

For more info, please download from <http://server.growatt.com>

T +86 755 2951 5888 F +86 755 2747 2131

E service@ginverter.com W www.growatt.com

GR-UM-129-K-00

Step1. General information-Specification

Voltage input	Rated voltage	3×220/400V
	Reference frequency	50Hz/60Hz
	Power consumption	<2W
Current input	Input current	0.5-10(100)A
	Starting current	0.004Ib
	Power consumption	<1VA (maximum current)
Pulse	Pulse width	200/100/60ms
	Pulse constant	400imp/kWh
Communication	Interface	RS485(A+, B-)
	Protocol	MODBUS, DL/T 645-2007

Overall dimension	L×W×H	100mm×72mm×66mm
Maximum onnecting capacity	Flexible cable	16mm ²
Temperature range	Working temperature	-25°C~55°C
	Storage temperature	-40°C~70°C
Humidity		≤90%(no condensation)
Altitude		<2000m

Step2. General information-Parts List

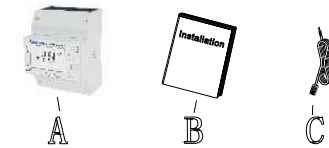

NO.	Quantity	Description
A	1	Three-phase Electronic Multifunctional Electric Energy Meter
B	1	User Manual
C	1	Rs485 communication cable (Standard wire length 5m)

Step3. Operation and Display

Forward reactive electric energy will be displayed after being electrified. Screen flip display can be realized through three types view button. The specification on various display interface sequences is as follows:

Phase A voltage, Phase B voltage, Phase C voltage, Phase A current, Phase B current, Phase C current, frequency, date, time, communication address, software version number, full screen test.

Phase A active power, Phase B active power, Phase C active power, total active power, Phase A reactive power, Phase B reactive power, Phase C reactive power, total reactive power, Phase A apparent power, Phase B apparent power, Phase C apparent power, total apparent power, Phase A power factor, Phase B power factor, Phase C power factor, total power factor, forward active maximum demand, reverse active maximum demand, forward reactive maximum demand, reverse reactive maximum demand.

Button icon	Button function
	Selects the Voltage and Current display screens In Set-up Mode, this is the "Left" or "Back" button.
	Select the Frequency and Power factor display screens In Set-up Mode, this is the "Up" button
	Select the Power display screens In Set-up Mode, this is the "Down" button.
	Select the Energy display screens In Set-up mode, this is the "Enter" or "Right" button

Forward active total electric energy, reverse active total electric energy, forward reactive total electric energy, reverse reactive total electric energy, forward active maximum electric energy, forward active peak electric energy, forward active normal electric energy, forward active valley electric energy, reverse active maximum electric energy, reverse active peak electric energy, reverse active normal electric energy, reverse active valley electric energy, forward reactive maximum electric energy, forward reactive peak electric energy, forward reactive normal electric energy, forward reactive valley electric energy, reverse reactive maximum electric energy, reverse reactive peak electric energy, reverse reactive normal electric energy, reverse reactive valley electric energy, Phase A forward active electric energy, Phase B forward active electric energy, Phase C forward active electric energy.

Step4. Wiring and Installation

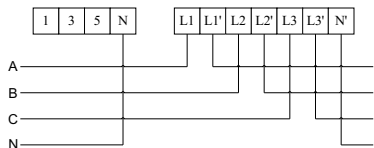

Three-phase four-wire connected in directly

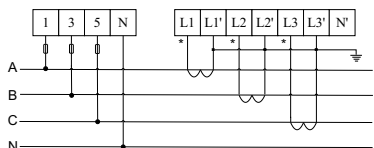

Three-phase four-wire connected in through mutual inductor

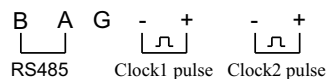

Communication and pulse output terminal

Note: We describe Growatt-SPH6000 and Growatt-SPH11000 TL3-HV as "SPH" as below.

a. When SPH series products are used in three-phase power grid system, please set the "CT mode" of SPH as "Meter Mode".

More details, please refer to SPH user manual.

b. When connecting three-phase energy meter, SPH gets the information of the sum of three-phase active power to process the logical control by RS485 communication.

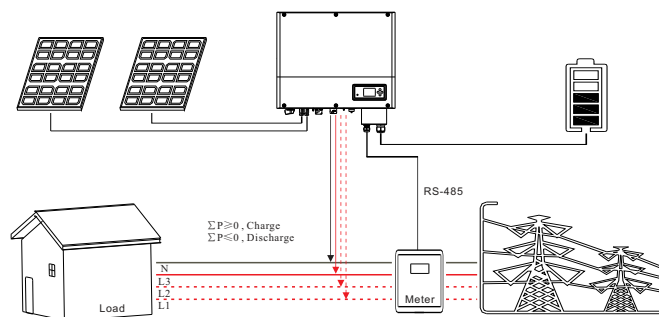

c. Install the three-phase energy meter in inlet AC distribution cabinet, and connect it to the utility grid (L1, L2, L3) according to responding indicator mark. The arrow on the meter indicates the grid access port.

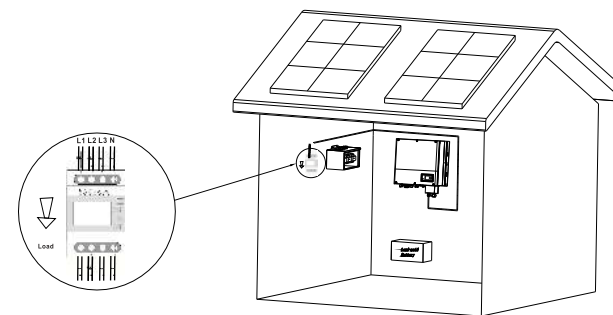

d. Connect the end of the RS485 cable to SPH RJ45(Sensor) port.

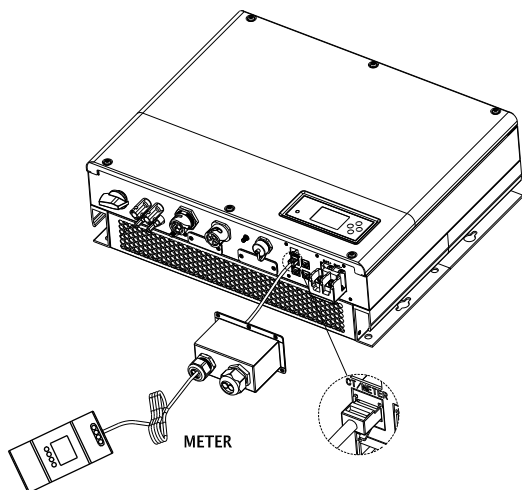

e. Connect the A+ of RS485 cable to Pin7 and B- of it to Pin8.

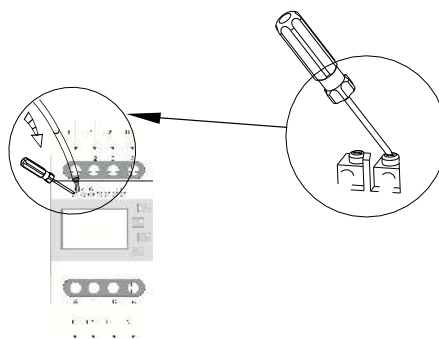

f. The standard RS485 cable length is 5m. If the length is not long enough, please add another cable to extend the length.

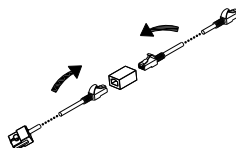

Step5. Trouble shooting

1. LED status: the indicator LED is flashing or off.

Description:

(1) the red light is pulse output. the flash frequency of the red light can show the power strength. the bigger power measured, the red light will flash faster.

2. Fault description: the measurement is not inaccurate.

Suggestion: check the wiring of inlet and outlet of energy meter. Namely, make sure that the wiring of A/B/C (three phase) of energy meter is matched with the A/B/C phase of utility grid.

3. Fault description: the energy meter failed to communicate with SPH.

Suggestion:

(1) check the "CT mode" of SPH is "energy meter mode".

(2) check the voltage between A+ and B- is within the range of + (4.4~4.5)V

(3) check the RS485 communication cable is right. That is to say the A+ / B+ of energy meter is matched to A+ / B- of SPH. Also, make sure the wiring is fixed firmly.